



RENEWAL PARTS

NO. 9007

MIDDLETOWN & NEW JERSEY RAILWAY CO.
MIDDLETOWN, N.Y.

ONE 44-TON DIESEL ELECTRIC LOCOMOTIVE
CLASS B-B-88/88-4GE733

ROAD NO.

1

2

SERIAL NO.

28487

28342

GENERAL  ELECTRIC



RENEWAL PARTS CATALOG

NO. 9687

MIDDLETOWN & NEW JERSEY RAILWAY CO.
MIDDLETOWN, N.Y.

ONE 44-TON DIESEL ELECTRIC LOCOMOTIVE
CLASS B-B-88/88-4GE733

ROAD NO.

1

2

SERIAL NO.

28487

28342

REVISED
11-14-57

PLEASE SPECIFY LOCOMOTIVE SERIAL NUMBER WHEN ORDERING PARTS

LOCOMOTIVE AND CAR EQUIPMENT DEPARTMENT

GENERAL  ELECTRIC

ERIE, P.A.

RENEWAL-PARTS CATALOG NO.

NO.-9687

MIDDLETOWN & NEW JERSEY RAILWAY CO.
MIDDLETOWN, N.Y.SERIAL No.
28487REVISED
11-14-57**PUBLICATION
NUMBER**TABLE OF CONTENTS AND EQUIPMENT LISTMECHANICAL PARTS

CAB AND TRUCKS

GEG-4720

ENGINE AND ACCESSORIESDIESEL ENGINE, CATERPILLAR MODEL D17000
EXHAUST SILENCER, MAXIM No. 8, MODEL No. MU
MAXIM SILENCER Co., HARTFORD, CONN.

GEG-3861

GAGES:

OIL PRESSURE,

RECEIVER UNIT, CAT. No. 6729122P1

SENDING UNIT, CAT. No. 6729122P2

WATER TEMPERATURE,

RECEIVER UNIT, CAT. No. 6729121P1

SENDING UNIT, CAT. No. 6729121P2

LUBRICATING OIL FILTER, NUGENT No. 1280A, SIZE 4L

GEG-4361

OIL COOLER, CAT. No. 4717788P1

RADIATOR, CAT. No. 6753579P1

MOTOR AND GENERATOR

TRACTION MOTOR, MODEL No. 5GE733J1

GEF-3265

AXLE LINING, ADJACENT TO COLLAR, CAT. No. 6732842G1

AXLE LINING, ADJACENT TO GEAR, CAT. No. 6732842G2

GEAR UNIT, MODEL No. 7GA33C1

GEF-3264

TRACTION GENERATOR, MODEL No. 5GT555A1

GEF-2949

EXCITER AUXILIARY GENERATOR, MODEL No. 5GMG140A1

GEF-2933

CONTROLLER AND REVERSER

CONTROLLER, TYPE 17KC63A1 WITH

OPERATING HANDLE, CAT. No. 4711188

GEF-3282

REVERSER, TYPE ME-78-C4

GEF-2510

CONTACTORS AND INTERLOCKS

AUXILIARY GENERATOR, TYPE 17CM15CC61 AND

INTERLOCK, TYPE 17AF14K3

GEF-3211

ENGINE STARTING, TYPE 17CM12J17 AND

INTERLOCK, TYPE 17AF14H9

GEF-2791

GEF-3041

EXCITER FIELD, TYPE 17CM15CC61 AND

INTERLOCK, TYPE 17AF14K1

GEF-2791

GEF-3211

GEF-2791

RENEWAL-PARTS CATALOG NO.

NO.-9687

MIDDLETOWN & NEW JERSY RAILWAY CO.
MIDDLETOWN, N.Y.

SERIAL No.
28487

COMPILED
11-14-57

PUBLICATION
NUMBER

CONTACTORS AND INTERLOCKS (CONT'D)

FIELD SHUNTING, TYPE 17CM15HH60	GEF-2776
FIELD SHUNTING, TYPE 17CM15HH60 AND INTERLOCK, TYPE 17AF14F2	GEF-2776 GEF-2791
FIELD SHUNTING, TYPE 17CM15HH60 AND INTERLOCK, TYPE 17AF14F3	GEF-2776 GEF-2791
LINE, TYPE 17CM12BE20 AND INTERLOCK, TYPE 17AF14H2	GEF-3120 GEF-2791
LINE, TYPE 17CM12BE20 AND INTERLOCK, TYPE 17AF14H4	GEF-3120 GEF-2791

PANELS AND RESISTORS

PANELS:

CAPACITOR, TYPE 17FM20A1 WITH
CAPACITOR, CAT. No. 5204557

EXCITER FIELD, BATTERY CHARGING AND
ELECTRIC GAGES, CAT. No. 6725789, TYPE 17FR23A1 WITH
1 RESISTOR UNIT, CAT. No. 2793981G31
1 RESISTOR UNIT, CAT. No. 2793985G27
1 RESISTOR UNIT, CAT. No. 2793985G24
1 RESISTOR UNIT, CAT. No. 2793985G21

EXCITER FIELD, BATTERY CHARGING, HEADLIGHTS,
AND HEATER FAN, CAT. No. 6725790, TYPE 17FR23B1 WITH
1 RESISTOR UNIT, CAT. No. 2793981G31
1 RESISTOR UNIT, CAT. No. 2793985G27
2 RESISTOR UNITS, CAT. No. 2793985G26
1 RESISTOR UNIT, CAT. No. 2793985G21
1 RESISTOR UNIT, CAT. No. 2793985G28

RESISTOR:

MOTOR FIELD SHUNTING, CAT. No. 6725721 Box 1,2,3,4

Box No.	TYPE	No. OF UNITS	UNIT CAT.No.
1	17EW101R2	1	42D6G394
2	17EW101R2	1	42D6G394
3	17EW101R2	1	42D6G394
4	17EW101R2	1	42D6G394

GEF-3153

RENEWAL-PARTS CATALOG NO.

NO.-9687

MIDDLETOWN & NEW JERSEY RAILWAY CO.
MIDDLETOWN, N.Y .

SERIAL No.
28487

REVISED
11-14-57

PUBLICATION
NUMBER

RELAYS AND SWITCHES

RELAYS:

FIELD SHUNTING, TYPE 17LC24C1	GEF-3048
FIELD SHUNTING DROP-OUT, TYPE 17LS8B3	GEF-3034
REVERSE CURRENT, TYPE 17LC19D8	GEF-3425
VOLTAGE CONTROL, TYPE 17LH13D6 AND	GEF-3030
RELAY, TYPE 17LC23L26	GEF-2907
TIME DELAY, TYPE 17LV30F6	GEF-3281

SWITCHES:

BATTERY, DPST, 200-AMP., 125V., CAT. No. TU-1101	
CONTROL, LIGHTS & HEATERS, DP, CAT. No. TC-2228S	
ENGINE STARTING, CAT. No. CR2943-U103A (SPECIFY START No. 1 OR No. 2)	
THROTTLE CONTROL, TYPE 17HE8D1	GEF-3072

AIR EQUIPMENT

OPERATING EQUIPMENT:

	<u>N.Y.A.B.</u>	<u>W.A.B.</u>	
	<u>Pc. No.</u>	<u>Pc.No.</u>	
K-14-F BRAKE VALVE	N-5452	521414	*3208-4
10 IN. BY 12 IN. EQUALIZING RESERVOIR	N-3426	99574	2215
1 IN. CUTOUT COCK	N-3090	2135	*3216-4
MAIN & EQUALIZING RESERVOIR AIR GAGE	N-4300	71672	
BRAKE PIPE & BRAKE CYLINDER AIR GAGE	N-4301	71671	
FEED VALVE WITH PIPE BRACKET (70-90 LB. SETTING)	N-1471	84192	*3209-2
REDUCING VALVE (SET AT 70 LBS.)	N-1469	84432	*3209-2
(6KR DISTRIBUTING VALVE)	N-7318	542842	*3212-2SUP.6
3/4 IN. CUTOUT COCK	N-3083	99081	*3216-4
3/4 IN. CENTRIFUGAL DIRT COLLECTOR	N-1214	77573	*3216-2
COMBINED STARINER AND CHECK VALVE	53-DC	24898	*3216-24
3/8 IN. CUTOUT COCK	117-SC	22459	*3216-4
<u>BRAKE PIPE EQUIPMENT:</u>			
1 1/4 IN. BY 1 1/4 IN. ANGLE COCK	N-3445	502526	*3216-4SUP.10
1 3/8 IN. BY 22 IN. HOSE WITH FP-5 COUPLING AND 1 1/4 IN. NIPPLE	N-1727	87101	*3216-3
"F" DUMMY COUPLING	HC-420	20806	
<u>MAIN RESERVOIR EQUIPMENT:</u>			
20 3/8 IN. BY 60 IN. MAIN RESERVOIR			
1/2 IN. CUTOUT COCK FOR DRAIN	N-3077	99085	*3216-4
MAIN RESERVOIR SAFETY VALVE (SET 150 LB.)	N-6642	536995	*3216-6
1 IN. MAIN RESERVOIR CUTOUT COCK	87-SC	11905	*3216-4
1 IN. CENTRIFUGAL DIRT COLLECTOR	N-3359	501138	*3216-2

*SEE W.A.B. BULLETIN

RENEWAL-PARTS CATALOG NO.

NO. -9687

MIDDLETOWN & NEW JERSEY RAILWAY CO.
MIDDLETOWN, N.Y.

SERIAL No.
28487

REVISED
11-14-57

PUBLICATION
NUMBER

AIR EQUIPMENT (CONT'D)

	N.Y.A.B. Pc.No.	W.A.B. Pc.No.	
<u>BRAKE CYLINDER EQUIPMENT:</u>			
6 IN. BY 8 IN. TYPE "B" DRIVER BRAKE			
CYLINDERS	N-5390	519820	GEG-4240
3/4 IN. BY 3/4 IN. BY 3/8 IN. THREE WAY COCKS	N-3128	99086	*3216-4 SUP.9
1 1/8 IN. BY 30 IN. HOSE WITH 3/4 IN. FITTINGS	N-7617	546901	*3216-3
3/4 IN. CHOKE FITTINGS	DC-101	11644	
<u>HORN EQUIPMENT:</u>			
A-2 PNEUPHONIC HORN	N-5429	519828	*3224-1
3/8 IN. STRAINER	N-1597	79452	
3/8 IN. CUTOUT COCK	N-3074	500291	*3216-4
1/2 IN. BY 3/8 IN. WHISTLE VALVE	SW-1	31422	*3224-1
<u>CONTROL AIR EQUIPMENT:</u>			
3/8 IN. CUTOUT COCK	N-3074	500291	*3216-4
3/8 IN. STRAINER	N-1597	79452	*3216-2 SUP.11
<u>COMPRESSOR & AUXILIARY EQUIPMENT:</u>			
COMPRESSOR, GARDNER-DENVER TYPE ADS 9003			GEG-3854
GOVERNOR, TYPE NS-16	N-5683	85270	*3205-10
(SET AT 130-140 LBS.)			
3/8 IN. GOVERNOR CUTOUT COCK	N-3444	501065	*3216-4

MISCELLANEOUS EQUIPMENT

AMMETER, CAT. No. A700EB

AMMETER SHUNT, CAT. No. 35X99

BATTERY, CAT. No. 4739746AC, EXIDE, 32-CELL, TYPE KT19A

NOTE: IF BATTERY PARTS ARE REQUIRED, ORDER FROM G.E.

SPECIFYING THE ABOVE CATALOG NUMBER, BATTERY

MANUFACTURER, SERIAL NUMBER FROM TRAY AND

STATING WHAT REPLACEMENT PARTS ARE REQUIRED.

CAB HEATER, CAT. No. 8826963AA

GEG-3971

CABLES:

530 FT. 450/24 AWG, SI-12250, MOTOR & ENGINE STARTING

270 FT. 37/24 AWG, SI-12250, GENERATOR FIELD &

BATTERY CHARGING

250 FT. 19/27 AWG, SI-12250, CONTROL

1300 FT. No. 16 AWG, PACKARD SPEC. 54022-R

CABLE CONNECTOR, CAT. No. 2710334

GEE-168

CIRCUIT BREAKER, 15 AMP., 125 VOLTS, CAT. No. 1GB115

*SEE W.A.B. BULLETIN

RENEWAL-PARTS CATALOG NO.

NO. -9687

MIDDLETOWN & NEW JERSEY RAILWAY CO.
MIDDLETOWN, N.Y.SERIAL NO.
28487REVISED
11-14-57**PUBLICATION
NUMBER**MISCELLANEOUS EQUIPMENT (CONT'D)

CONNECTION BOARD, TYPE 17BC2D1	GEE-826
FIRE EXTINGUISHER, BUFFALO FIRE APPLIANCE CO'S. SUPER CTC, 1 1/2 QT.	
FUSES:	
4-AMP, 250 VOLTS, CAT. No. GE1455	GEE-18A
35 AMP., CAT. No. 426C711ACP16	
60 AMP., CAT. No. 426C711ACP20	
FUSE CUTOUTS:	
CAT. No. 36803, BATTERY & AUXILIARY GENERATOR	
CAT. No. 189666, AUXILIARY GENERATOR FIELD	
HEADLIGHT, PYLE NATIONAL, TYPE C-620-GN	GEG-3870
VISOR, PYLE NATIONAL CO'S. PT.No. 14035-WFS	
LAMPS:	
250 WATTS, 60 VOLTS, P-25 BULB, C-5 FILAMENT WITH MEDIUM SCREW BASE AND 3 IN. LCL	
25 WATTS, 70 VOLTS, A-19 BULB, MAZDA "B" INSIDE FROSTED, MEDIUM SCREW BASE	
PLUG RECEPTACLE, PYLE NATIONAL, TYPE MRFA-1	GEG-5035
TOOLS:	
PINION PULLERS & GAGE, CAT. No. 4729566G1	
WRENCHES FOR FLUTED SOCKET HEAD CAP SCREWS	
CAT. No. 89X419 FOR 5/16 IN. SCREW (TEE)	
CAT. No. 98X100 FOR No. 10 SCREW (OFFSET)	
CAT. No. 98X101 FOR 1/4 IN. SCREW (OFFSET)	
SPANNER WRENCH, CAT. No. 260513	
VALVE GAGE, CAT. No. 1499733	
VALVES:	
BELL RINGER, KING No. 14	GEG-3881
SANDER, KING No. 29	GEG-3882
VOLTMETER, BATTERY, CAT. No. A701AW	
WATER HEATER, PURITAN MODEL No. 406-C	GEG-3885
WINDOW WIPERS:	
C.A. SPRAGUE DEVICES, STANDARD "AIR PUSH"	GEG-3887
18 IN. ARM, 14 IN. BLADE WITH 70 DEG. SWEEP (FOR END WINDOW)	
11 IN. ARM, 14 IN. BLADE WITH 90 DEGREE SWEEP (FOR END DOOR)	
1/8 IN. VALVE, CAT. No. 600X56	

HOW TO USE THIS PARTS CATALOG

TO SAVE YOU TIME

This catalog is provided to save you time and money in ordering parts. It affords an easy and accurate means of identifying the correct parts for the equipments covered by this catalog.

TO ORDER PARTS

1. To be sure you have the applicable catalog, check the serial number of the locomotive with the serial number shown on the title page of this catalog.

(NOTE: The serial number of a locomotive remains the same throughout its life, even though the road number may be changed.) All correspondence should refer to the serial number.

2. Determine the type or model number designation of the device from the index pages in the front portion of the catalog. (These index pages list the exact equipment furnished on your apparatus when it left the factory.) The applicable renewal parts bulletin is listed opposite each device. These bulletins are filed in numerical sequence following the index pages.

3. Determine from the bulletin the following data for each part required:

a. Quantity

Obtain this information from the number required column. The quantity listed is for one relay not one locomotive.

b. Catalog Number

Where the bulletin covers several models (types) of a device, be sure to read the quantity listed in the column for your particular model number.

In the example shown there are four listings for base with support. The quantity under B2 indicates that one Cat. No. 144X91 is required for Type 17LH28B2 Relay. Catalog numbers 141X39, 179X94, and 188X49 are for other models and will not fit Type 17LH28B2.

c. Description

This will help you to double-check your order. These three items -- quantity, catalog number, and description -- should be included in your order for parts.

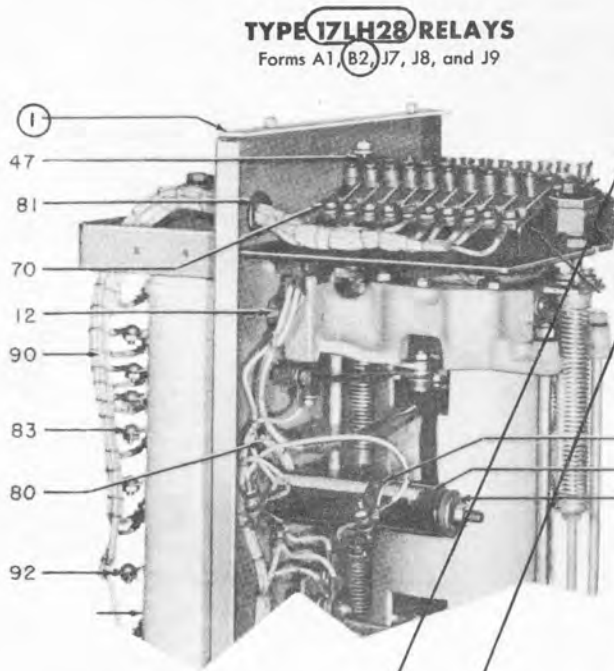

Ref. No.	No. Required for Type 17LH28-					Cat. No.	Description
	A1	B2	J7	J8	J9		
1	1	1				141X39	Base with supports
1		1				144X91	Base with supports
1			1	1		179X94	Base with supports
1					1	188X49	Base with supports
2	1	1	1	1	1	4757154	Spring catch with rivets for cover support
3	1	1	1	1	1	4737876	Magnet frame tube
4	1					4739397	Field coil
4		1	1	1	1	4739452	Field coil

4. Indentations are used in the descriptions of parts to indicate in what assemblies or sub-assemblies parts may be procured. On an order for an assembly, all of the parts indented under it will be supplied. For example, an order for one Cat. 6734339G2, commutator, will procure all the indented items following it -- shell, cap, set of segments, mica collar, mica cones, screws, and washers -- assembled as a seasoned commutator. An order for one Cat. 4729580P5 will procure only the shell for commutator as there are no parts indented under it.

Ref. No.	Cat. No.	No. Req.	Description
86	6734339G2	1	Commutator (seasoned)
87	4729580P5	1	Shell for commutator
88	4729581P2	1	Cap for commutator
89	355X64	12	Screw fastening cap to shell, 3/4 in. -10, 3 1/4 in. hex. soc. h.
90	8805547P1	12	Washer for 3/4 in. diam screw
91	6734339P4	1	§Set of copper and mica commutator segments, finished and bound (must be seasoned after assembly on armature)
92	6705297P1	1	Mica collar under segments
93	8811166P1	2	Combination inner and outer mica cone for front or back of commutator
94	4713687	1	‡Balancing weight for armature, commutator end
95	4713686	1	‡Balancing weight for armature, pinion end
96	6734397G1	1	Shaft with keys for punchings and commutator
97	4713668	1	Key for shaft and punchings
98	4713667	1	Key for shaft and commutator
99	99999	1	Lubricant for pinion or shaft

LOCOMOTIVE AND CAR EQUIPMENT DEPARTMENT

GENERAL  ELECTRIC

ERIE, PA.

TK-2278

***GEE-168 C**

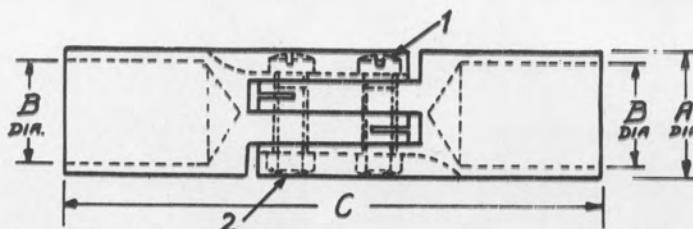

Connector with screws and nuts	Ref.No. 1	Ref.No. 2	Pivot	Dimension in Inches			Cable Size
	Screw	Nut		A	B	C	
	Catalog Number			A	B	C	
4703298	-----	-----	415974	3/4	1/2	5	175/24 to 325/24 inc.
2710334	11D801	11D800	-----	1	5/8	4 3/4	275/24 to 450/24 inc.
11D798	11D801	11D800	-----	1	13/16	4 3/4	450/24 to 650/24 inc.
11D802	11D805	11D804	-----	1 1/4	1	5 5/8	775/24 to 1100/24 inc.
11D775	11D778	11D777	-----	1 1/2	1 3/16	6	1325/24 to 1600/24 inc.
11D806	11D809	11D808	-----	1 7/8	1 1/2	7 1/2	1925/24 to 2750/24 inc.

When ordering renewal parts, give quantity of each item required, catalog number, and description.

***GEE-168 C**

CABLE CONNECTORS FOR TRANSPORTATION CONTROL EQUIPMENT APPARATUS

JUNE, 1938
Filing No. B9160

NOTE:-Data subject to change without notice.

*Supersedes GEE-168B.

GENERAL ELECTRIC
SCHENECTADY, N.Y.

RENEWAL PARTS



TYPE 17BC2A1, -B1, -C1, AND -D1 CONNECTION BOARDS

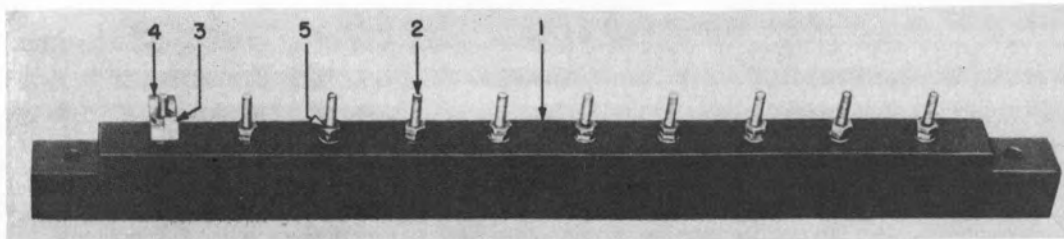

Ref. No.	No. Req. for Type 17BC2-				Cat.No.	Description
	A1	B1	C1	D1		
1	1				4702666	Connection block
1		1			4708625	Connection block
1			1		4708626	Connection block
1				1	4712141	Connection block
2	7				4731833P15	Screw fastening terminals to block (10-32)
2		10	12		70X38	Screw fastening terminals to block (10-32)
2				6	4765696P26	Screw fastening terminals to block (10-32)
3	14	20	24	12	410567	Terminal, left-hand
4	14	20	24	12	434048	Terminal, right-hand
5	28	40	48		151175	Nut (10-32)
5				12	145996	Nut (10-32)
	14	30	36	12	150279	Plain washer for No. 10 screw
	14	30	36	12	54X441	Lock washer for No. 10 screw
	A1	B1	C1	D1		

When ordering renewal parts, give quantity, catalog number, description of each item required, and complete nameplate reading.

11-57 (2C)

GENERAL  ELECTRIC

GENERAL ELECTRIC RENEWAL PARTS

TYPE ME-78-C1, -C2, -C3, AND -C4 REVERSERS

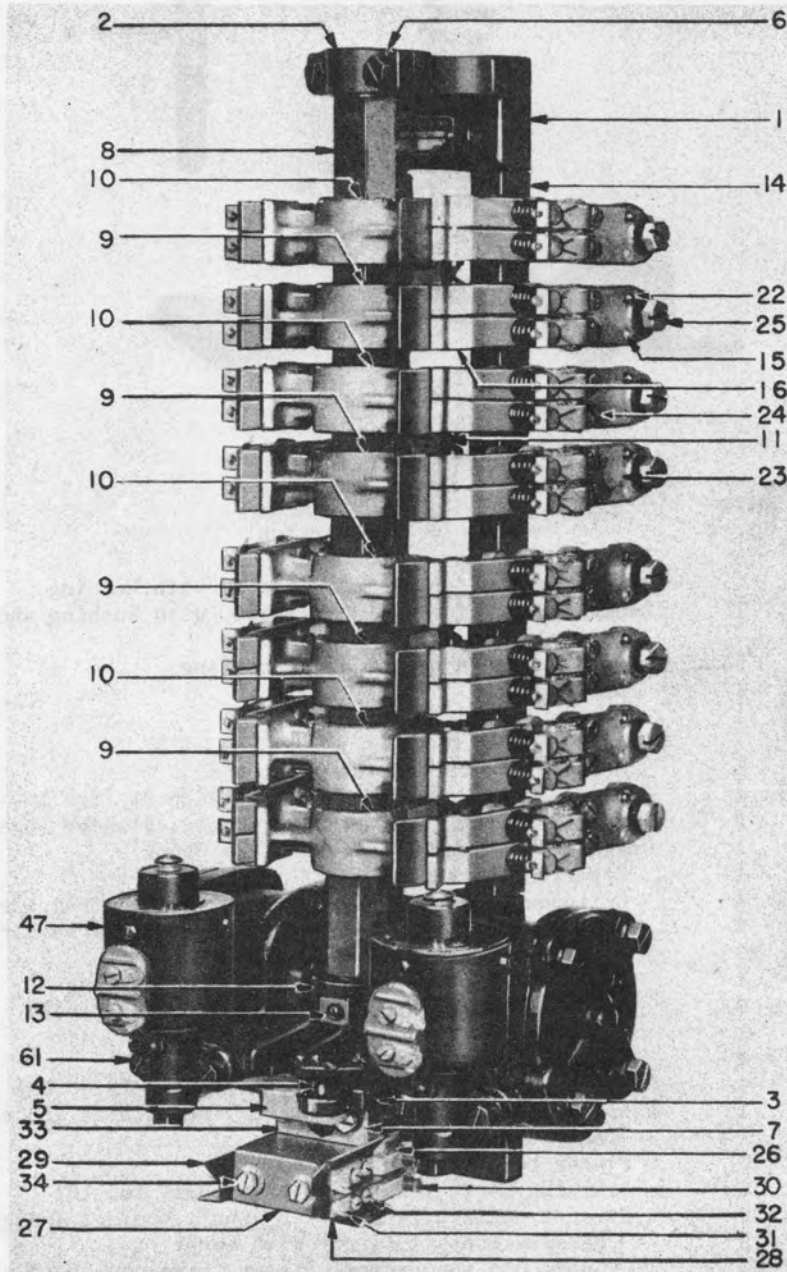

Type ME-78-C4 Reverser

When ordering renewal parts, give quantity, catalog number, description of each item required, and complete nameplate reading.

Note: Data subject to change without notice.

GENERAL ELECTRIC

GEF-2510C

TYPE ME-78 REVERSERS

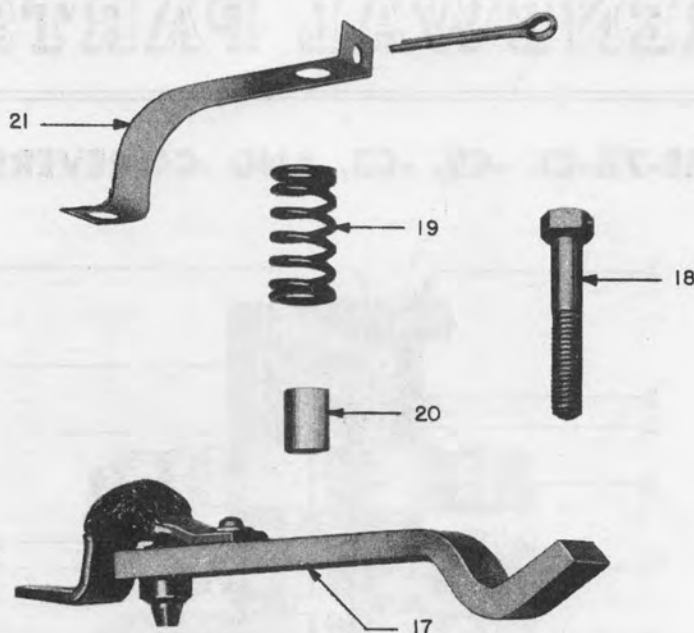

Ref. No. 16
Reverse Contact Finger

Ref. No.	Cat.No.	No.Re-quired	Description
1	2137597P1	1	Bearing support
2	1829482G6	1	Upper bearing for cylinder shaft, with bushing
3	4754551	1	Lower bearing for cylinder shaft, with bushing and locking device for cylinder
	227X7	2	Bushing for upper or lower bearing
4	2403704	1	Locking pin
5	2403702	1	Handle for locking pin
	2403703	1	Latch pin for handle
	2766784	1	Compression spring for latch pin
6	150411	2	Screw fastening upper bearing to support (3/8 in.-16)
7	176354	2	Screw fastening lower bearing to air cylinder (3/8 in.-16)
	2743702G2	1	Cylinder with shaft and operating crank
8	2743702P18	1	Insulated hexagonal shaft
9	2139497P1	4	Cylinder casting, 1st, 3rd, 5th, or 7th from air cylinder end
10	2139497P2	4	Cylinder casting, 2nd, 4th, 6th, or 8th from air cylinder end
	235405	16	Clamping screw for cylinder casting
11	1437225	4	Insulation spacer between cylinder castings
	153923	8	Screw fastening spacer to casting (3/8 in.-16)
12	2137590P3	1	Operating crank for cylinder
13	111111	1	Set screw for operating crank
	2743806G1	1	Finger support, right-hand, with finger bases and contact fingers
	2743806G2	1	Finger support, left-hand, with finger bases and contact fingers
14	2743806P2	2	Finger support, insulated
15	31D244P1	16	Finger base
	155435	16	Clamping screw for finger base (5/16 in.-18)
16	4749597G2	32	Reverse contact finger with shunt, spring, and guide pin
17	6701912	32	Reverse contact finger with shunt
18	6711746	32	†Guide pin for contact finger, hexagonal head screw type
18	2427897	32	†Guide pin for contact finger, stud type
19	6724909	32	†Compression spring for Cat.6711746
19	2411274	32	†Compression spring for Cat.2411274

† Two designs of reverse contact fingers have been furnished for the above reversers. The first design, which will no longer be furnished, had a stud type of guide pin. The second design has a hexagonal head screw type of guide pin. The two designs of complete are interchangeable but the guide pin and compression spring are not. Therefore, care should be taken to determine the correct catalog number when ordering these parts.

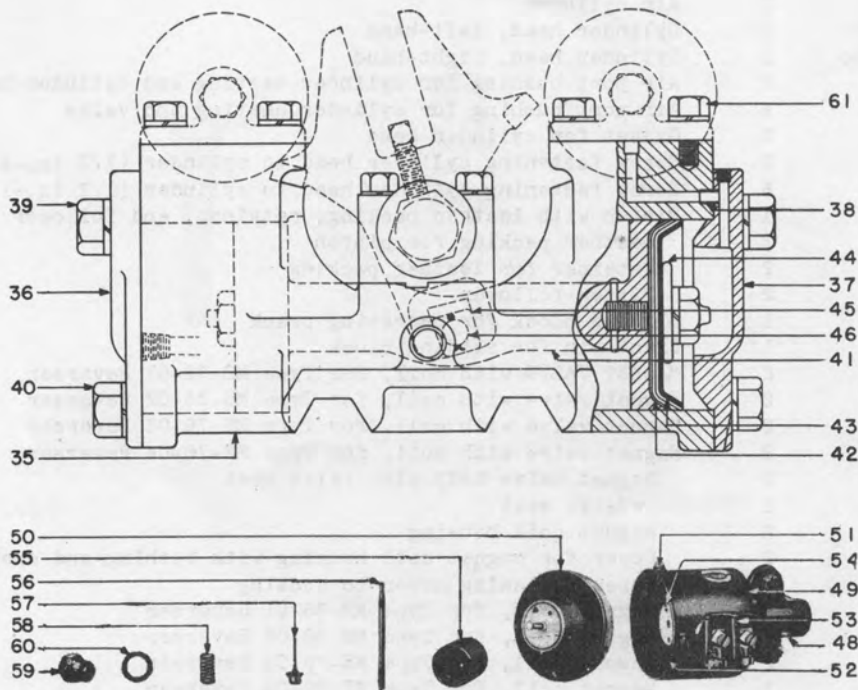

Air Cylinder Ref. No. 35 and Magnet Valve Ref. No. 47

Ref. No.	Cat.No.	No.Re-quired	Description
	1459265	32	Spring seat for Cat.2411274
20	11D46	32	Sleeve for guide pin
21	6712638	32	Locking plate for Cat.6711746
22	2407724	32	Dowel screw
23	2710400	16	Connection plate for contact finger and terminal
24	17366	32	Screw fastening connection plate and finger shunt to finger base
	11D649	Δ	Punched copper tube cable terminal (0.586 in. cable hole)
	11D650	Δ	Punched copper tube cable terminal (0.669 in. cable hole)
	4702785	Δ	Punched copper tube cable terminal (0.776 in. cable hole)
	4702830	Δ	Punched copper tube cable terminal (0.881 in. cable hole)
	4702832	Δ	Punched copper tube cable terminal (0.944 in. cable hole)
25	144029	16	Screw fastening terminal to finger base (1/2 in.-13)
26	2728604G1	1	Interlock cylinder with contact segments
	4754262	1	Cylinder body
	4704188	1	Contact segment
	4704195	2	Filler segment
	218975	5	Screw for segment
	4704193	1	Pin fastening interlock cylinder to shaft
	2728605G1	1	Interlock finger block with contact fingers
27	4704194	1	Finger block
28	4704190	3	Finger base
29	2705935	3	Insulation shield for finger base
	63X863	6	Wood screw for finger base
30	2705831	3	Contact finger
31	417591	3	Terminal
32	105136	6	Screw fastening contact finger and terminal to finger base (10-32)
	4715216	1	Insulation between interlock finger block and support
33	4704192	1	Support for interlock finger block

Δ Quantity variable.

GENERAL ELECTRIC

GEF-2510C

TYPE ME-78 REVERSERS

Ref. No.	Cat.No.	No.Re-quired	Description
34	48X46	2	Screw fastening finger block to support (1/4 in.-20)
35	257963	1	Air cylinder
36	2137589G9	1	Cylinder head, left-hand
37	2137589G10	1	Cylinder head, right-hand
38	1482832	2	Air port bushing for cylinder casting and cylinder head
	1486402	4	Air port bushing for cylinder casting and valve
	1451211	2	Gasket for cylinder head
39	170952	2	Screw fastening cylinder head to cylinder (1/2 in.-13, 1 1/2 in.)
40	144029	6	Screw fastening cylinder head to cylinder (1/2 in.-13, 1 1/4 in.)
41	261173	1	Piston with leather packing, retainer, and follower
42	1404050	2	Leather packing for piston
43	1404054	2	Retainer for leather packing
44	1400159	2	Piston follower
45	2406474	1	Sliding block for operating crank
46	100X347	1	Pivot pin for sliding block
47	259320	2	MAGNET VALVE with coil, for Type ME-78-C1 Reverser
47	205157	2	Magnet valve with coil, for Type ME-78-C2 Reverser
47	20X611	2	Magnet valve with coil, for Type ME-78-C3 Reverser
47	203855	2	Magnet valve with coil, for Type ME-78-C4 Reverser
48	203856	2	Magnet valve body with valve seat
	193565	2	π Valve seat
49	1404097	2	Magnet coil housing
50	2440254	2	Cover for magnet coil housing with bushing and operating pin
51	1419701	8	Screw fastening cover to housing
52	206449	2	Magnet coil, for Type ME-78-C1 Reverser
52	205158	2	Magnet coil, for Type ME-78-C2 Reverser
52	203962	2	Magnet coil, for Type ME-78-C3 Reverser
52	203798	2	Magnet coil, for Type ME-78-C4 Reverser
	2431106	2	Insulation washer between housing and coil
	4731834P9	4	Connection screw for magnet coil
53	1431116	2	Insulator for connection screws
54	1419780	2	Magnet core
	54X274	2	Set screw for magnet core
55	1415914	2	Armature
56	1416765	2	Exhaust stem
57	1416763	2	Inlet valve
58	170634	2	Compression spring for inlet valve
59	1416772	2	Cap plug
60	499960	2	Copper gasket for cap plug
	1401951	2	Gasket between magnet valve and air cylinder
61	143937	4	Screw fastening magnet valve to air cylinder (3/8 in.-16)
	150411	4	Screw fastening air cylinder in position (3/8 in.-16)

PLAIN WASHERS

Cat.No.	Description
150279	For No. 10 screw
143974	For 1/4 in. screw
145598	For 5/16 in. screw
141259	For 3/8 in. screw
84X301	For 1/2 in. screw

LOCK WASHERS

Cat.No.	Description
54X441	For No. 10 screw
30X562	For 1/4 in. screw
6X814	For 5/16 in. screw
6X815	For 3/8 in. screw
10X903	For 1/2 in. screw

NUTS

145996	10-32, hex. std
126869	5/16 in.-18, hex. std
141257	3/8 in.-16, hex. std, jam

COTTER PINS

110174	3/32 in. by 5/8 in.
174253	1/8 in. by 1/2 in.
133468	1/8 in. by 3/4 in.

π Air port must be drilled in valve seat after assembly with valve body.

APPARATUS DEPARTMENT

GENERAL ELECTRIC

SCHENECTADY, N. Y.

RENEWAL PARTS

TYPE 17CM15K, -BN, -DD, AND -HH CONTACTORS

NOTE: The last number in the nameplate rating is the coil number.

EXAMPLE: Type 17CM15K6 requires operating coil Cat. 2738570.

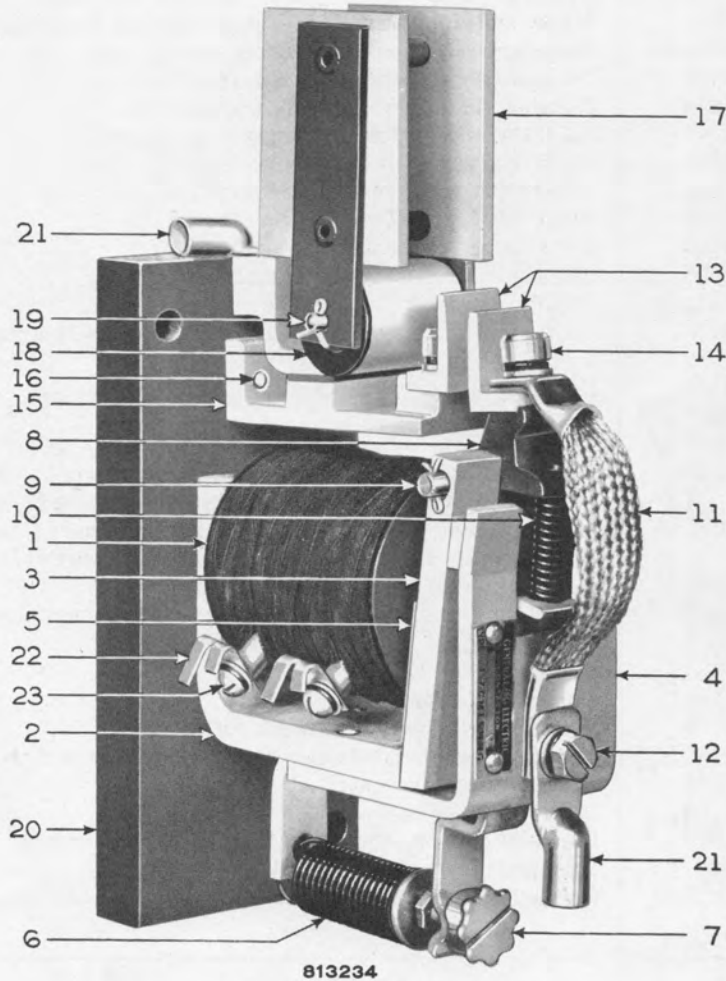

Type 17CM15K Contactor

Ref. No. 1 - OPERATING COILS - (1 Required)

Coil No.	Cat. No.	Coil No.	Cat. No.	Coil No.	Cat. No.	Coil No.	Cat. No.
5	‡2738516	11	‡2738101	55	4739333	77	4739477
6	‡2738570	13	‡2738613	60	4739370	81	4739486
9	‡2738589	25	‡2738573	75	4739475		

‡ See page 3 for table of new design operating coils

When ordering renewal parts, give quantity, catalog number, description of each item required, and complete nameplate reading.



TYPE 17CM15 CONTACTORS

Ref. No.	No. Req. for Type 17CM15-				Cat. No.	Description
	K	DD	HH	BN		
	1	1	1		4710326	Rubber washer for operating coil
	2	2	2	2	256488	Screw fastening operating coil to magnet frame (6-40)
	1	1	1	1	6713726	Insulation between magnet frame and base
2	1	1	1	1	4768903AC	Magnet frame
3	1	1	1	1	4709833AA	Magnet core for operating coil
	1	1	1	1	112303	Screw for magnet core and frame (5/16 in.-18)
	2		2	2	46X820	Screw fastening magnet frame in position (1/4 in.-20)
4	1	1	1	1	4737858AB	Armature stop
	2	2	2	2	20X555	Screw fastening armature stop to magnet frame (1/4 in.-20)
5	1	1	1	1	6742072G1	Armature with spring bracket
6	1	1	1		4769764	Tension spring with plug, for armature
6				1	4731974	Tension spring with plug, for armature
7	1	1	1	1	6700342	Adjusting screw for tension spring (10-32)
8	1	1	1	1	4711038	Contact lever with bushing
	1	1	1	1	4750841	†Bushing for contact lever
9	1	1	1	1	4709826	Hinge pin for contact lever
10	1	1	1	1	4769765	Compression spring for contact lever
10				1	8862945	Compression spring for contact lever
11	1	1	1	1	6721611G1	Flexible shunt for contact lever
12	1	1	1	1	20X555	Screw fastening flexible shunt and terminal to armature stop (1/4 in.-20)
13	2				4711042	Contact tip
13		2	2		4711041	Contact tip
13				2	8814397	Contact tip
14	2		2	2	46X820	Screw fastening contact tip and flexible shunt to contact lever or contact tip to stationary contact support (1/4 in.-20)
		2			91X85	Screw fastening contact tip and flexible shunt to contact lever or contact tip to stationary contact support (1/4 in.-20)
15	1	1	1	1	2735312G2	Stationary contact support and blowout coil
16	3	1	3	3	46X847	Screw fastening stationary contact support and blowout coil or terminal in position (1/4 in.-20)
17	1	1	1	1	2735364G1	Arc chute
	1	1	1	1	4711560	Core for blowout coil
	1	1	1	1	4711559	Insulation sleeve for blowout coil core
18	2	2	2	2	4711570	Insulation washer between blowout coil and arc chute
19	1	1	1	1	4759978	Hinge pin for arc chute
20	1		1	1	4711564	Mounting base
21	2		2	2	4711677	Punched copper tube cable terminal
22	2	2	2	2	410567	Terminal for operating coil
23	2	2	2	2	4731833P4	Screw fastening terminal to operating coil (10-32)
	K	DD	HH	BN		

Note: The following items are steel unless otherwise specified.

PLAIN WASHERS

Cat. No.	Description
196351	For No. 6 screw
150279	For No. 10 screw
143974	For 1/4 in. screw

NUT

151175	10-32, hex. std, brass
--------	------------------------

LOCK WASHERS

Cat. No.	Description
54X595	For No. 6 screw
54X441	For No. 10 screw
71X749	For No. 10 screw, Shakeproof
30X562	For 1/4 in. screw
6X814	For 5/16 in. screw

COTTER PIN

168996	1/16 in. by 3/8 in.
--------	---------------------

†Bushing may be replaced by using burnishing tool Cat. No. 4735725P2.

TYPE 17CM15 CONTACTORS

Two designs of operating coils have been furnished for the Type 17CM15 Contactor. The first design of operating coil Fig. 1 has round spool flanges at both ends; the second design Fig. 2 has one round and one offset spool flange which provides for fastening to the contactor frame by using two 6-40, 3/8 in. r.h. screws Cat. No. 256488. This design prevents breaking connections by the turning of the operating coil.

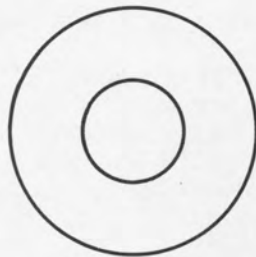

Fig. 1

PBA-76760

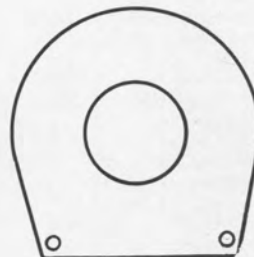
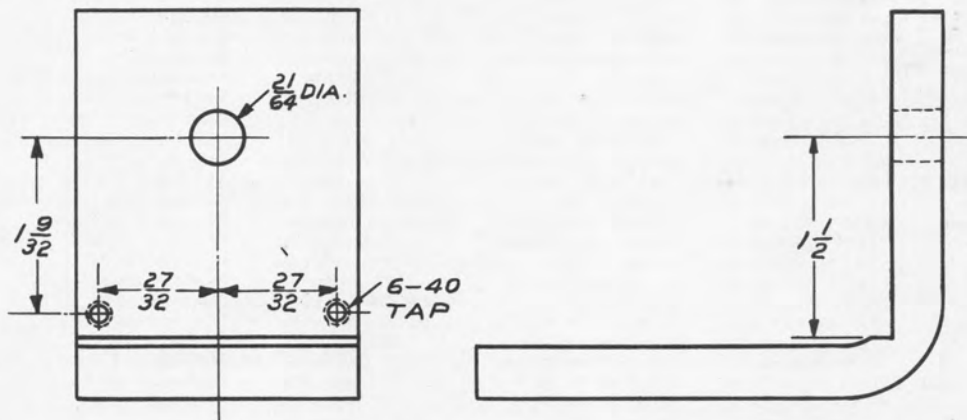

Fig. 2

Operating Coils listed in this table are interchangeable, except that the contactor frame must be machined in accordance with Fig. 3 before the operating coils of the second design can be applied. The rubber washer used with operating coils of the first design Fig. 1 are not required for the second design Fig. 2.

Operating Coil	Cat. No.
Fig. 1 Design	Fig. 2 Design
2738101	4739333
2738516	4739401
2738570	4739333
2738573	4739370
2738589	4739316
2738613	4739318



PBA-76761

Fig. 3

1. Remove partial radius in bend of frame as shown
2. Drill and tap frame locating two tapped holes from the center of the present 21/64 in. diam hole in frame.
3. Place new design coil retainer furnished with coil between core body and coil spool with long end inside coil and short end under core head.

WHEN YOU NEED SERVICE

IF YOU NEED TO REPAIR, recondition, or rebuild any electric apparatus, a G-E service shop near you is available day and night, seven days a week, for work in the shops or on your premises. Latest factory methods and genuine G-E renewal parts are used to maintain the original performance of your G-E equipment. For full information about these services, contact the nearest service shop or sales office listed below:

APPARATUS SERVICE SHOPS

Atlanta—Chamblee, Ga. 4639 Peachtree Indus. Blvd.
 Baltimore 30, Md. 920 E. Fort Ave.
 Boston—Medford 55, Mass. Mystic Valley Pkwy.
 Buffalo 11, N. Y. 318 Urban St.
 Charleston 28, W. Va. 306 MacCorkle Ave., S.E.
 Charlotte, N. C. 2328 Thrift Road
 Chicago 80, Ill. 849 S. Clinton St.
 Cincinnati 2, Ohio 444 W. Third St.
 Cleveland 4, Ohio 4966 Woodland Ave.
 Columbus 15, Ohio 213 Cozzens St.
 Dallas 9, Texas 3202 Manor Way
 Denver 5, Colo. 3353 Larimer St.
 Detroit 2, Mich. 5950 Third Ave.
 Houston 20, Texas 5534 Harvey Wilson Drive
 Johnstown, Pa. 841 Oak St.
 Kansas City 8, Mo. 819 E. 19th St.
 Los Angeles 1, Calif. 6900 Stanford Ave.
 Milwaukee 3, Wisc. 940 W. St. Paul Ave.
 Minneapolis 12, Minn. 2025 49th Ave., N.
 New York 14, N. Y. 416 W. 13th St.
 Philadelphia 23, Pa. 429 N. Seventh St.
 Pittsburgh 6, Pa. 6519 Penn Ave.
 Portland 18, Oregon Swan Island
 Richmond 24, Va. 1403 Ingram Ave.
 St. Louis 10, Mo. 1115 East Road



San Francisco 3, Calif. 1098 Harrison St.
 Salt Lake City 4, Utah 301 S. Seventh West St.
 Seattle 4, Wash. 3422 First Ave., S.

Toledo 4, Ohio 1 So. St. Clair St.
 York, Pa. 54 N. Harrison St.
 Youngstown 5, Ohio 272 E. Indianola Ave.

APPARATUS SALES OFFICES

Akron 8, Ohio 335 S. Main St.
 Albany 7, N. Y. 90 State St.
 Albuquerque, N. Mex. 323 Third St., S.W.
 Allentown, Pa. 1014 Hamilton St.
 Amarillo, Texas 719 Amarillo Bldg.
 Appleton, Wisc. 531 W. College Ave.
 Atlanta 3, Ga. Peachtree Rd. at 28th St., N.W.
 Augusta, Ga. Eighth & Broad Sts.
 Augusta, Me. 15 Grove St.
 Bakersfield, Calif. 211 E. 18th St.
 Baltimore 1, Md. 111 Park Ave.
 Bangor, Maine 77 Central St.
 Battle Creek, Mich. 25 W. Michigan Ave.
 Beaumont, Texas 1385 Calder Ave.
 Binghamton, N. Y. 19 Chenango St.
 Birmingham 3, Ala. 1804 Seventh Ave., N.
 Bismarck, N. Dak. 117 1/2 Fifth St.
 Bluefield, W. Va. P.O. Box 447, Appalachian Bldg.
 Boston 1, Mass. 140 Federal St.
 Buffalo 3, N. Y. 535 Washington St.
 Butte, Mont. P.O. Box 836, 103 N. Wyoming St.
 Canton 2, Ohio 700 Tuscarawas St., W.
 Cedar Rapids, Iowa 210 Second St., S.E.
 Charleston 28, W. Va. 306 MacCorkle Ave., S.E.
 Charlotte 1, N. C. 200 S. Tryon St.
 Charlottesville, Va. 123 E. Main St.
 Chattanooga 2, Tenn. 832 Georgia Ave.
 Chicago 80, Ill. P.O. Box 5970A, 840 S. Canal St.
 Cincinnati 2, Ohio 215 W. Third St.
 Cleveland 4, Ohio 4966 Woodland Ave.
 Columbia 1, S.C. P.O. Box 1434, 1420 Lady St.
 Columbus 15, Ohio 40 S. Third St.
 Corpus Christi, Texas 205 N. Chaparral St.
 Dallas 2, Texas 1801 N. Lamar St.
 Davenport, Iowa 511 Pershing Ave.
 Dayton 2, Ohio 118 W. First St.
 Denver 2, Colo. 650 Seventeenth St.
 Des Moines 9, Iowa 505 W. Fifth Ave.
 Detroit 2, Mich. 700 Antoinette St.
 Duluth 2, Minn. 14 W. Superior St.
 Elmira, N. Y. Main and Woodland Aves.
 El Paso, Texas 109 N. Oregon St.
 Erie 2, Pa. 1001 State St.
 Eugene, Ore. 29 W. Eleventh St.
 Evansville 19, Ind. 123 N.W. Fourth St.
 Fairmont, W. Va. 310 Jacobs Bldg., P.O. Box 1626
 Fergus Falls, Minn. 102 W. Lincoln St., P.O. Box 197
 Flint, Mich. 653 S. Saginaw St.

Fort Wayne 2, Ind. 127 W. Berry St.
 Fort Worth 2, Texas 408 W. Seventh St.
 Fresno 1, Calif. Tulare and Fulton St.
 Grand Rapids 2, Mich. 148 Monroe Ave., N.W.
 Greensboro, N. C. 301 S. Elm St.
 Greenville, S. C. 108 W. Washington St.
 Hagerstown, Md. Professional Arts Bldg.
 Harrisburg, Pa. 300 N. Second St.
 Hartford 3, Conn. 410 Asylum St.
 Houston 1, Texas 1312 Live Oak St.
 Huntsville, Ala. E. Holmes St.
 Indianapolis 4, Ind. 110 N. Illinois St.
 Jackson, Mich. 120 W. Michigan Ave.
 Jackson 1, Miss. 203 W. Capitol St.
 Jacksonville 2, Fla. 700 E. Union St.
 Jamestown, N. Y. P.O. Box 548, 2 Second St.
 Johnson City, Tenn. 321-323 W. Walnut St.
 Johnstown, Pa. 841 Oak St.
 Joplin, Mo. 220 W. Fourth St.
 Kansas City 6, Mo. 106 W. Fourteenth St.
 Knoxville 08, Tenn. 602 S. Gay St.
 Lansing 8, Mich. 106 W. Allegan St.
 Lincoln 8, Nebr. 1001 "O" St.
 Little Rock, Ark. 103 W. Capitol Ave.
 Los Angeles 54, Calif. 212 N. Vignes St.
 Louisville 2, Ky. 455 S. Fourth St.
 Macon, Ga. 682 Cherry St.
 Madison 3, Wisc. 16 N. Carroll St.
 Manchester, N. H. 875 Elm St.
 Medford, Ore. P.O. Box 1349, 205 W. Main St.
 Memphis 3, Tenn. 8 N. Third St.
 Miami 32, Fla. 25 S.E. Second Ave.
 Milwaukee 3, Wisc. 940 W. St. Paul Ave.
 Minneapolis 3, Minn. 12 S. Sixth St.
 Mobile 13, Ala. 54 St. Joseph St.
 Montgomery 4, Ala. 121 Molton St.
 Nashville 3, Tenn. 234 Third Ave., N.
 Newark 2, N. J. 744 Broad St.
 New Haven 6, Conn. 129 Church St.
 New Orleans 12, La. 837 Gravier St.
 New York 22, N. Y. 570 Lexington Ave.
 Niagara Falls, N. Y. 253 Second St.
 Norfolk 10, Va. 229 W. Butte St.
 Oakland 12, Calif. 409 Thirteenth St.
 Oklahoma City 2, Okla. 119 N. Robinson St.
 Omaha 2, Nebr. 409 S. Seventeenth St.
 Paducah, Ky. P.O. Box 1001, 231 S. Fourth St.
 Pasco, Wash. 421 W. Clark St.
 Peoria 2, Ill. 309 Jefferson Bldg.
 Philadelphia 2, Pa. 1405 Locust St.

Phoenix, Ariz. P.O. Box 4037, 303 Luhrs Tower
 Pittsburgh 22, Pa. 535 Smithfield St.
 Portland 3, Maine 477 Congress St.
 Portland 7, Ore. 920 S.W. Sixth Ave.
 Portsmouth, Ohio 721 Sixth St.
 Providence 3, R. I. Industrial Trust Bldg.
 Raleigh, N. C. 336 Fayetteville St.
 Reading, Pa. 31 N. Sixth St.
 Richmond 17, Va. 700 E. Franklin St.
 Riverside, Calif. 3808 Main St.
 Roanoke 16, Va. 920-924 S. Jefferson St.
 Rochester 4, N. Y. 89 E. Ave.
 Rockford, Ill. 110 S. First St.
 Rutland, Vt. 38 1/2 Center St.
 Sacramento 14, Calif. 626 Forum Bldg.
 Saginaw, Mich. 501 Bearinger Bldg.
 St. Louis 2, Mo. 112 N. Fourth St.
 Salt Lake City 9, Utah 200 S. Main St.
 San Antonio 5, Texas 310 S. St. Mary's St.
 San Diego 1, Calif. 1240 Seventh Ave.
 San Francisco 6, Calif. 235 Montgomery St.
 San Jose 10, Calif. 460 Park Ave.
 Savannah, Ga. 4 E. Bryan St.
 Seattle 4, Wash. 710 Second Ave.
 Shreveport, La. 1513 Line Ave.
 Sioux City, Iowa 572 Orpheum Electric Bldg.
 Sioux Falls, S. D. 321 1/2 S. Phillips Ave.
 South Bend 11, Ind. 112 W. Jefferson Blvd.
 Spokane 8, Wash. S. 162 Post St.
 Springfield, Ill. 607 E. Adams St.
 Springfield 3, Mass. 1387 Main St.
 Stockton, Calif. 11 So. San Joaquin St.
 Syracuse 2, N. Y. 113 S. Salina St.
 Tacoma 1, Wash. 1202 Washington Bldg.
 Tampa 6, Fla. 1206 North A St.
 Toledo 4, Ohio 420 Madison Ave.
 Trenton 8, N. J. 214 E. Hanover St.
 Tulsa 3, Okla. 320 S. Boston Ave.
 Utica 2, N. Y. 258 Genesee St.
 Washington 5, D.C. 777-14th St., N.W.
 Waterbury 89, Conn. 111 W. Main St.
 Waterloo, Iowa 206 W. 4th St.
 Wheeling, W. Va. 40 Fourteenth St.
 Wichita 2, Kan. 200 E. First St.
 Williamston, N. C. City Hall
 Wilmington 98, Del. 1326 N. Market St.
 Worcester 8, Mass. 507 Main St.
 York, Pa. 56 N. Harrison St.
 Youngstown 5, Ohio 272 E. Indianola Ave.

Hawaii: American Factors, Ltd., P. O. Box 3230, Honolulu 1 Canada: Canadian General Electric Company, Ltd., Toronto

LOCOMOTIVE AND CAR EQUIPMENT DEPARTMENT, GENERAL ELECTRIC COMPANY, ERIE, PA.



RENEWAL PARTS

TYPE 17AF14 INTERLOCKS

Forms F1, F2, F3, F4, F9, F12, F18, F20, F21, F28, H1, H2, H3, H4, H5, H7, H8, H9, H10, H12, H13, H14, H15, H16, H17, H25, H26, H29, J1, J2, J3, J4, J5, J6, J7, J8, J9, J10, J22, J24, K1, K3, K5, K7, K9, K13, K15, K18, K23, K27, L2, L4, M3, M9, N1, N2, N9, R3, S2, S18, and V31.

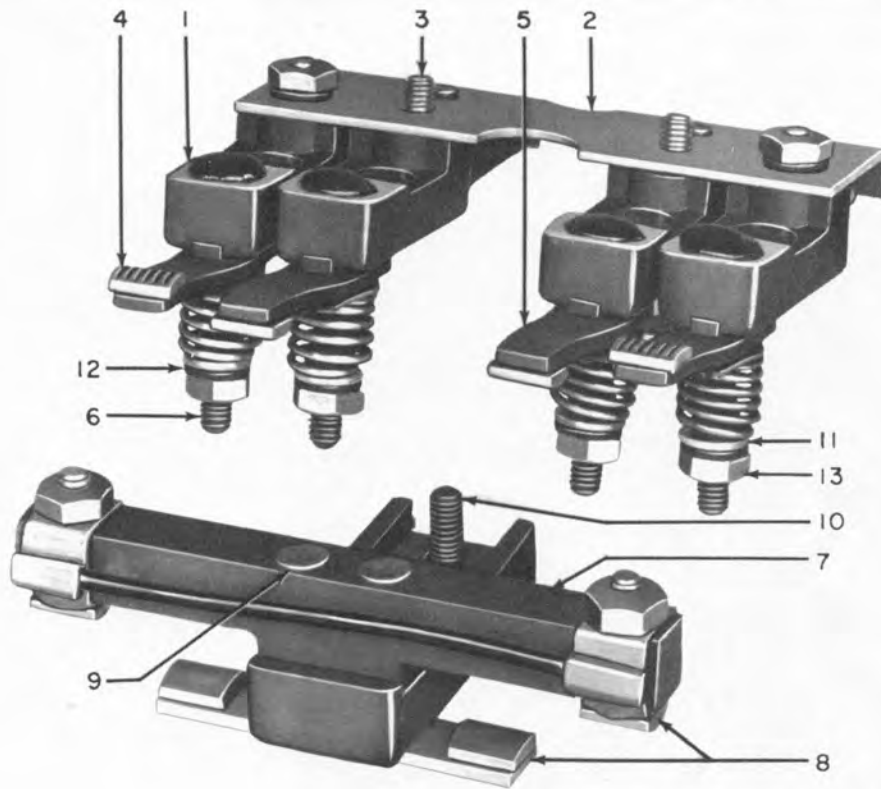

Type 17AF14S18 interlock

(NEG 5013096)

Type 17AF14-	Ref. No. 2		Ref. No. 4		Ref. No. 5		Ref. No. 7		Ref. No. 8		Ref. No. 9	
	Cat. No.	No. Req.	Cat. No.	No. Req.	Cat. No.	No. Req.	Cat. No.	No. Req.	Cat. No.	No. Req.	Cat. No.	No. Req.
	Mounting Plate for Finger Supports		Contact Finger with Compression Spring		Contact Finger with Compression Spring		Movable Contact with Operating Arm and Contact Tips		Contact Tip for Movable Contact		Rivet Fastening Contact Tip in Position	
F1	6700793	1	6700314	2	-----	-	6700779	1	4709859	1	195X61	2
F2	6700793	1	-----	-	6700284	2	6700779	1	4709859	1	195X61	2
F3	4710777	1	6700314	2	6700284	2	6700777	1	4710497	2	195X66	2
F4	4710777	1	-----	-	6700284	4	6700778	1	4710497	2	195X67	2
F9	4710777	1	6700314	4	-----	-	6700778	1	4710497	2	195X67	2
F12	4710777	1	6700314	2	6700284	2	6702536	1	4710497	2	195X66	2
F18	4710777	1	6700314	2	6700284	2	8862390G2	1	†4709859	2	195X70	2
F20	4710777	1	-----	-	6700284	4	6700778	1	06714320	1	-----	-
									4710497	2	195X67	2

† Two holes
0 With screw

When ordering renewal parts, give quantity, catalog number, description of each item required, and complete nameplate reading.

GENERAL  ELECTRIC

TYPE 17AF14 INTERLOCKS

Type 17AF14-	Ref. No. 2		Ref. No. 4		Ref. No. 5		Ref. No. 7		Ref. No. 8		Ref. No. 9	
	Mounting Plate for Finger Supports		Contact Finger with Compression Spring		Contact Finger with Compression Spring		Movable Contact with Operating Arm and Contact Tips		Contact Tip for Movable Contact		Rivet Fastening Contact Tip in Position	
	Cat. No.	No. Req.	Cat. No.	No. Req.	Cat. No.	No. Req.	Cat. No.	No. Req.	Cat. No.	No. Req.	Cat. No.	No. Req.
F21	6703425	1	6700314	2	6700284	4	8860097G1	1	#4710497 ¶4709859	2 1	195X66 195X70	2 2
F28	6700793	1	-----	-	8860819G2	2	6700779	1	4709859	1	195X61	2
H1	4710410	1	6700314	2	-----	-	6701849	1	4709859	1	195X61	2
H2	4710410	1	-----	-	6700284	2	6701849	1	4709859	1	195X61	2
H3	4710452	1	6700314	2	6700284	2	6701850	1	4710497	2	195X66	2
H4	4710452	1	-----	-	6700284	4	6701998	1	4710497	2	195X67	2
H5	4711276	1	6700314 /6700316	1 1	6700284	3	6702000	1	4710497	3	195X66	3
H7	4712240	1	6700314	4	6700284	2	4735720G1	1	#4710497 ¶4709859	2 1	195X67 195X70	2 2
H8	4712240	1	6700314	2	6700284	4	4731514G1	1	#4710497 ¶4709859	2 1	195X59	4
H9	4710452	1	6700314	4	-----	-	6701998	1	4710497	2	195X67	2
H10	6700057	1	6700314 /6700316	3 1	6700284	3	4734203G1	1	#4710497 ¶4709859	3 1	195X66 197X59	1 4
H12	4710452	1	6700314	2	6700284	2	6702536	1	4710497	2	195X66	2
H13	4712240	1	6700314	2	6700284	4	8823753G1	1	#4710497 ¶4709859	2 1	197X67 195X34	2 2
H14	4711276	1	6700314	3	6700284	2	6703680	1	#4710497 ¶6703682	1 1	195X66	3
H15	4711276	1	6700314 /6700316	3 1	6700284	1	6702000	1	4710497	3	195X66	3
H16	4712240	1	6700314	6	-----	-	6721675G1	1	#4710497 ¶4709859	2 1	195X67 195X70	2 2
H17	4711276	1	6700314	3	6700284	2	6711153	1	#4710497 ¶6703682	1 1	195X66	3
H25	4712240	1	6700314	4	6700284	2	8862373G1	1	#4710497 ¶8810391	2 1	195X66 195X70	2 2
H26	4712240	1	6700314	2	6700284	4	4731514G2	1	#4710497 +8810393 ¶4709859	1 1 1	197X59	4
H29	4712240	1	6700314	2	6700284	4	8862749G1	1	#4710497 ¶8810391	2 1	195X61 195X70	2 2
J1	6700602	1	6700314	2	-----	-	6701849	1	4709859	1	195X61	2
J2	6700602	1	-----	-	6700284	2	6701849	1	4709859	1	195X61	2
J3	6700603	1	6700314	2	6700284	2	6701850	1	4710497	2	195X66	2
J4	6700603	1	-----	-	6700284	4	6701998	1	4710497	2	195X67	2
J5	6700637	1	6700314 /6700316	1 1	6700284	3	6702000	1	4710497	3	195X66	3
J6	6700637	1	6700314 /6700316	1 1	6700284	3	6716340	1	4710497	3	195X66	3
J7	6700636	1	6700314	4	6700284	2	4735720G1	1	#4710497 ¶4709859	2 1	195X67 195X70	2 2
J8	6700636	1	6700314	2	6700284	4	4731514G1	1	#4710497 ¶4709859	2 1	197X59	4
J9	6700603	1	6700314	4	-----	-	6701998	1	4710497	2	195X67	2
J10	6700635	1	6700314 /6700316	3 1	6700284	3	4734203G1	1	#4710497 ¶4709859	3 1	195X66 197X59	1 4
J22	6700637	1	6700314	2	6700284	3	8860661G1	1	#4710497 ¶6703682	1 1	195X66	3
J24	6700603	1	6700314	2	6700284	2	8862375G1	1	#4710497 +6700774	1 1	195X66 195X67	1 1
K1	6700793	1	6700314	2	-----	-	6702374	1	4709859	1	195X68	2
K3	4710777	1	6700314	2	6700284	2	6702372	1	4710497	2	195X66	2

/ Double contact
One hole
¶ Two holes
+ Raised tips

TYPE 17AF14 INTERLOCKS

GEF-2791F

Type 17AF14	Ref. No. 2		Ref. No. 4		Ref. No. 5		Ref. No. 7		Ref. No. 8		Ref. No. 9	
	Mounting Plate for Finger Supports		Contact Finger with Compression Spring		Contact Finger with Compression Spring		Movable Contact with Operating Arm and Contact Tips		Contact Tip for Movable Contact		Rivet Fastening Contact Tip in Position	
	Cat. No.	No. Req.	Cat. No.	No. Req.	Cat. No.	No. Req.	Cat. No.	No. Req.	Cat. No.	No. Req.	Cat. No.	No. Req.
K5	6700308	1	6700314 /6700316	1 1	6700284	3	6716420	1	4710497	3	195X66	3
K7	6703425	1	6700314	4	6700284	2	8827798G1	1	#4710497 †4709859	2 1	195X67 195X69	2 2
K9	4710777	1	6700314	4	-----	-	8802773	1	4710497	2	195X67	2
K13	6703425	1	6700314	2	6700284	4	4737374	1	#4710497 †4709859	2 1	195X66 195X71	2 2
K15	8803318	1	6700314 /6700316	3 1	6700284	1	8803319	1	4710497	3	195X66	3
K18	4710777	1	6700314	2	6700284	2	8862390G1	1	†4709859 06714320	1 2	195X70 -----	2 -
K23	4710777	1	8860819G1	2	8860819G2	2	6702372	1	4710497	2	195X66	2
K27	4710777	1	6700314	2	8860819G2	2	6702372	1	4710497	2	195X66	2
L2	6700793	1	-----	-	6706332	2	6700779	1	4709859	1	195X61	2
L4	4710777	1	-----	-	6706332	4	6700778	1	4710497	2	195X67	2
M3	4710452	1	6700314AA	2	6700284AA	2	6701850	1	4710497	2	195X66	2
M9	4710452	1	6700314AA	4	-----	-	6701998	1	4710497	2	195X67	2
N1	6700793	1	6700314AA	2	-----	-	6700779	1	4709859	1	195X61	2
N2	6700793	1	-----	-	6700284AA	2	6700779	1	4709859	1	195X61	2
N9	4710777	1	6700314AA	4	-----	-	6700778	1	4710497	2	195X67	2
R3	4710777	1	6700314	2	6700284	2	6703121	1	4710497	2	195X66	2
S2	4710777	1	6700314	2	-----	-	6725326G2	1	06714320	2	-----	-
S18	4710777	1	6700314	2	6700284	2	6725326G1	1	†6714322 06714320	1 2	197X59 -----	2 -
V31	4710777	1	6700314	2	6700284	2	6725326G3	1	†6714322 06714320	1 2	195X34 -----	2 -

Ref. No.	Cat. No.	Description
1	8860652	ΔSupport for contact finger
	4712667	ΔInsulation for support
3	128616	ΔScrew fastening contact finger support in position (10-32, 5/8 in. r. h.)
3	133767	ΔScrew fastening contact finger support in position (10-32, 1/2 in. fill. h.)
6	6700283	ΔGuide for contact finger and compression spring (10-32, plain)
6	6700283AA	ΔGuide for contact finger and compression spring (10-32, chromium plated)
	6700285	ΔNut for guide (bottom)
	6703679	ΔShim between support and mounting plate, brass
	6712184	ΔShim between support and mounting plate, steel
	417591	ΔTinned copper terminal, straight
	434048	ΔTinned copper terminal, right-hand
	410567	ΔTinned copper terminal, left-hand
10	105136	ΔScrew for operating arm (10-32, 1/2 in. r. h.)
10	87X885	ΔScrew for operating arm (10-32, 1/2 in. fluted socket h.)
11	150279	ΔPlain washer for No. 10 screw
12	54X441	ΔLock washer for No. 10 screw
13	145996	ΔNut (10-32, hex. std)

- / Double contact
- # One hole
- † Two holes
- Δ Quantity variable
- θ With screw
- + Raised tips

WHEN YOU NEED SERVICE

IF YOU NEED TO REPAIR, recondition, or rebuild any electric apparatus, a G-E service shop near you is available day and night, seven days a week, for work in the shops or on your premises. Latest factory methods and genuine G-E renewal parts are used to maintain the original performance of your G-E equipment. For full information about these services, contact the nearest service shop or sales office listed below:

APPARATUS SERVICE SHOPS

*Denotes Aircraft Service Shops

Albany, N. Y. 1097 Central Ave.
 Allentown, Pa. 668 E. Highland St.
 Appleton, Wisc. Midway Industrial Area,
 County Trunk, "P" P.O. Box 83
 Atlanta—Chamblee, Ga. 4639 Peachtree
 Indus. Blvd.
 *Arkansas City, Kan. P.O. Box 526
 Baltimore 30, Md. 920 E. Fort Ave.
 Boston—Medford 55, Mass. 3960 Mystic
 Valley Pkwy.
 Buffalo 11, N. Y. 318 Urban St.
 Charleston 28, W. Va. 306 MacCorkle Ave., S.E.
 Charlotte, N. C. 2328 Thrift Road
 Chicago 32, Ill. 4360 W. 47th St.
 Cincinnati 2, Ohio 444 W. Third St.
 *Cincinnati 3, Ohio 956 E. Court St.
 Cleveland 4, Ohio 4966 Woodland Ave.
 Columbus 23, Ohio 2128 Eakin Rd.
 Corpus Christi, Texas 115 Busse St.
 *Dallas, Texas 1135-1215 S. Lamar St.
 Dallas 19, Texas 3202 Manor Way
 Davenport—Bettendorf, Ia. 1039 State St.
 Decatur, Ill. 2225 E. Logan St.
 Denver 5, Colo. 3353 Larimer St.
 Detroit 2, Mich. 5950 Third Ave.
 Ft. Wayne, Ind. 606 W. Superior St.
 Houston 20, Texas 5534 Harvey Wilson Drive
 Indianapolis 22, Ind. 1740 W. Vermont St.
 Johnstown, Pa. 841 Oak St.
 Kansas City 20, Mo. 3525 Gardner Ave.
 Los Angeles 1, Calif. 6900 Stanford Ave.
 Louisville, Ky. 2014 New Main St.
 Midland, Tex. 3404 Bankhead Hwy.
 Milwaukee 3, Wisc. 940 W. St. Paul Ave.
 Minneapolis 12, Minn. 2025 49th Ave., N.
 New Orleans, La. 2815 N. Robertson St.
 New York—N. Bergen, N. J. 6001 Tonnelle Ave.
 Oakland, Calif. 1525 Peralta St.
 *Ontario, Calif. Ont. Int'l Airport
 Philadelphia 24, Pa. 1040 E. Erie Ave.
 Pittsburgh 6, Pa. 6519 Penn Ave.
 Portland 10, Oregon 2727 N.W. 29th Ave.
 Richmond 24, Va. 1403 Ingram Ave.
 Roanoke, Va. 115 Albermarle St.
 Sacramento, Calif. 99 N. 17th St.
 St. Louis 10, Mo. 1115 East Road
 Salt Lake City 4, Utah 301 S. Seventh West St.
 San Francisco 3, Calif. 1098 Harrison St.
 Seattle 4, Wash. 3422 First Ave., S.
 *Seattle 4, Wash. 3422 First Ave., S.
 Southington, Conn. 53 Railroad Ave.
 Spokane 3, Wash. S. 155 Sherman St.
 Tampa 1, Fla. P.O. Box 1245,
 Naval Indus. Res. Shipyard
 Toledo 4, Ohio 1 So. St. Clair St.
 Wheeling, W. Va. 2050 National Rd.
 York, Pa. 54 N. Harrison St.
 Youngstown 7, Ohio 272 E. Indianola Ave.

APPARATUS SALES OFFICES

Abilene, Texas 442 Cedar St.
 Akron 8, Ohio 335 S. Main St.
 Albany 3, N. Y. 8 Colvin Ave.
 Albuquerque, N. Mex. 323 Third St., S.W.
 Alexandria, La. 720 Murray St.
 Allentown, Pa. 1132 Hamilton St.
 Amarillo, Texas Amarillo Bldg.
 Appleton, Wisc. 510 W. College Ave.
 Atlanta 3, Ga. P.O. Box 4659
 1860 Peachtree Rd., N.W.
 Augusta, Ga. Masonic Bldg.
 Augusta, Me. 152 State St.
 Baltimore 1, Md. 111 Park Ave.
 Bangor, Maine P.O. Box 778, 77 Central St.
 Baton Rouge 6, La. 3170 Florida Blvd.
 Battle Creek, Mich. 25 W. Michigan Ave.
 Beaumont, Texas P.O. Box 2870
 1385 Calder Ave.
 Billings, Mont. Rm. 816, 303 No. Broadway
 Binghamton, N. Y. P.O. Box 931
 19 Chenango St.

Birmingham 3, Ala. P.O. Box 2602
 1804 Seventh Ave., N.
 Bismarck, N. Dak. 418 Rosser Ave.
 Bluefield, W. Va. P.O. Box 447, 704 Bland St.
 Appalachian Bldg.
 Boise, Idaho 1524 Idaho St.
 Boston 1, Mass. 140 Federal St.
 Buffalo 2, N. Y. 625 Delaware Ave.
 Butte, Mont. P.O. Box 836, 103 N. Wyoming St.
 Canton 2, Ohio 700 Tuscarawas St., W.E.
 Cedar Rapids, Iowa 210 Second St., S.E.
 Charleston 28, W. Va. P.O. Box 2313
 306 MacCorkle Ave., S.E.
 Charlotte 1, N. C. P.O. Box 1969
 112 S. Tryon St.
 Chattanooga 2, Tenn. 832 Georgia Ave.
 Chicago 80, Ill. P.O. Box 5970A, 840 S. Canal St.
 Cincinnati 2, Ohio 2621 Victory Pkwy.
 Cleveland 4, Ohio 4966 Woodland Ave.
 Columbia 1, S.C. P.O. Box 1434, 1420 Lady St.
 Columbus 15, Ohio 40 S. Third St.
 Corpus Christi, Texas 205 N. Chaparral
 Dallas 2, Texas 1801 N. Lamar St.
 Davenport—Bettendorf, Ia. P.O. Box 630
 1039 State St.
 Dayton 2, Ohio 11 W. Monument Bldg.
 Dayton 9, Ohio Avia. & Def.,
 2600 Far Hills Ave.
 Denver 2, Colo. P.O. Box 2331
 650 Seventeenth St.
 Des Moines 9, Iowa 505 W. Fifth Ave.
 Detroit 2, Mich. 700 Antoinette St.
 Duluth 2, Minn. 14 W. Superior St.
 Elmira, N. Y. P.O. Box 971
 Main and Woodlawn Aves.
 El Paso, Texas 215 No. Stanton
 Erie 2, Pa. 1001 State St.
 Eugene, Ore. 1170 Pearl St.
 Evansville 19, Ind. P.O. Box 157
 123 N.W. Fourth St.
 Fairmont, W. Va. P.O. Box 1626
 310 Jacobs Bldg.
 Fergus Falls, Minn. P.O. Box 197
 108 N. Court Ave.
 Flint 3, Mich. 653 S. Saginaw St.
 Fort Wayne 6, Ind. 3606 So. Calhoun St.
 Fort Worth 2, Tex. 408 W. Seventh St.
 Fort Worth, Tex. P.O. Box 9218, Avia. & Def.,
 6200 Camp Bowie Blvd.
 Fresno 1, Calif. 407 Patterson Bldg.
 Tulare and Fulton St.
 Grand Rapids 2, Mich. 425 Cherry St., S.E.
 Greensboro, N. C. P.O. Box 1162
 301 S. Elm St.
 Greenville, S. C. P.O. Box 1408
 108 W. Washington St.
 Gulfport, Miss. 207 Jo-Fran Bldg.
 Hagerstown, Md. P.O. Box 477
 Professional Arts Bldg.
 Hartford 5, Conn. 764 Asylum St.
 Houston 1, Texas 1312 Live Oak St.
 Indianapolis 4, Ind. 110 N. Illinois St.
 Jackson, Mich. 120 W. Michigan Ave.
 Jackson 1, Miss. 203 W. Capitol St.
 Jacksonville 2, Fla. Station G—Box 48
 700 E. Union St.
 Johnstown, Pa. 841 Oak St.
 Joplin, Mo. P.O. Box 948, 220½ W. Fourth St.
 Kalamazoo 3, Mich. P.O. Box 447
 114 Parkway Ave.
 Kansas City 6, Mo. 106 W. Fourteenth St.
 Knoxville 16, Tenn. 1301 Hannah Ave.
 Lake Charles, La. P.O. Box 5212
 422 Seventh St.
 Lansing 8, Mich. 814 Michigan National Tower
 Lexington, Ky. First National Bank Bldg.
 Lincoln 8, Nebr. Sharpe Bldg., 206 S. 13th St.
 Little Rock, Ark. 103 W. Capitol Ave.
 Los Angeles 54, Calif. 212 N. Vignes St.
 Louisville 2, Ky. 455 S. Fourth St.
 Lubbock, Texas P.O. Box 1464
 3302 Avenue "A"
 Macon, Ga. P.O. Box 1506, 682 Cherry St.
 Madison 3, Wisc. 16 N. Carroll St.

Manchester, N. H. 875 Elm St.
 Medford, Ore. P.O. Box 1349, 107 E. Main St.
 Memphis 3, Tenn. 8 N. Third St.
 Miami 32, Fla. P.O. Box 5062
 25 S.E. Second Ave.
 Midwest City, Okla. P.O. Box 5867
 Avia. & Def., 207 Post Off. Bldg.
 Milwaukee 3, Wisc. 940 W. St. Paul Ave.
 Minneapolis 3, Minn. 12 S. Sixth St.
 Mobile Ala. 704 Government St.
 Nashville 3, Tenn. 234 Third Ave., N.
 Newark 2, N. J. 744 Broad St.
 New Haven 6, Conn. 129 Church St.
 New Orleans 12, La. 837 Gravier St.
 New York 22, N. Y. 570 Lexington Ave.
 New York Avia. & Def., Fed. Bldg.,
 International Airport, Jamaica 30, N. Y.
 Niagara Falls, N. Y. 44 Fall St.
 Norfolk 10, Va. 229 W. Bute St.
 Oakland 12, Calif. P.O. Box 1106
 409 Thirteenth St.
 Oklahoma City 2, Okla. 119 N. Robinson St.
 Omaha 2, Nebr. 409 S. Seventeenth St.
 Pasco, Wash. P.O. Box 971, 824 W. Lewis St.
 Peoria 2, Ill. 309 Jefferson Bldg.
 Philadelphia 2, Pa. 3 Penn Center Plaza
 Phoenix, Ariz. P.O. Box 4037, 220 Luhrs Tower
 Pittsburgh 22, Pa. The Oliver Bldg., Mellon Sq.
 Portland 7, Ore. P.O. Box 909
 920 S.W. Sixth Ave.
 Providence 3, R. I. Industrial Trust Bldg.
 Raleigh, N. C. P.O. Box 2507
 16 W. Martin St.
 Reading, Pa. 31 N. Sixth St.
 Richmond 17, Va. P.O. Box 2188
 700 E. Franklin St.
 Riverside, Calif. 3570 Ninth St.
 Roanoke 16, Va. P.O. Box 871
 920 S. Jefferson St.
 Rochester 4, N. Y. 89 E. Ave.
 Rockford, Ill. 110 S. First St.
 Rutland, Vt. 38½ Center St.
 Sacramento 14, Calif. 626 Forum Bldg.
 Saginaw, Mich. Second National Bank Bldg.
 St. Louis 1, Mo. 818 Olive St.
 Salt Lake City 10, Utah P.O. Box 779
 200 S. Main St.
 San Antonio 5, Texas 434 So. Main Ave.
 San Diego 1, Calif. P.O. Box 1222
 1240 Seventh Ave.
 San Francisco 6, Calif. 235 Montgomery St.
 San Jose 10, Calif. 460 Park Ave.
 Savannah, Ga. 40 East Bay St.
 Seattle 4, Wash. P.O. Box 1858
 710 Second Ave.
 Seattle 8, Wash. Avia. & Def., 220 Dawson St.
 Shreveport, La. 206 Beck Bldg.
 Sioux City 13, Iowa 572 Orpheum Electric Bldg.
 South Bend 1, Ind. 112 W. Jefferson Blvd.
 Spokane 4, Wash. S. 162 Post St.
 Springfield, Ill. 607 E. Adams St.
 Springfield 3, Mass. 1387 Main St.
 Stockton, Calif. 11 So. San Joaquin St.
 Syracuse 6, N. Y. P.O. Box 1021
 3532 James St.
 Tacoma 1, Wash. P.O. Box 1485
 1202 Washington Bldg.
 Tampa 6, Fla. P.O. Box 3092, 1206 North A St.
 Toledo 4, Ohio 420 Madison Ave.
 Trenton 8, N. J. 214 E. Hanover St.
 Tucson, Ariz. P.O. Box 710, 650 N. Sixth Ave.
 Tulsa 3, Okla. 320 S. Boston Ave.
 Utica 2, N. Y. 258 Genesee St.
 Washington 5, D. C. 777-14th St., N.W.
 Waterloo, Iowa 206 W. 4th St.
 Wenatchee, Wash. P.O. Box 676
 328 N. Wenatchee Ave.
 Wheeling, W. Va. 40 Fourteenth St.
 Wichita 2, Kan. 200 E. First St.
 Williamston, N. C., P.O. Box 748, 115 E. Main St.
 Worcester 5, Mass. 288 Grove St.
 York, Pa. 56 N. Harrison St.
 Youngstown 5, Ohio 272 E. Indianola Ave.

Hawaii: American Factors, Ltd., P. O. Box 3230, Honolulu 1 Canada: Canadian General Electric Company, Ltd., Toronto

LOCOMOTIVE AND CAR EQUIPMENT DEPARTMENT, GENERAL ELECTRIC COMPANY, ERIE, PA.

RENEWAL PARTS



TYPE 17LV23 RELAY

Forms A, D, E, J, K, L, M, R, T, Y, AA, AC, and AD

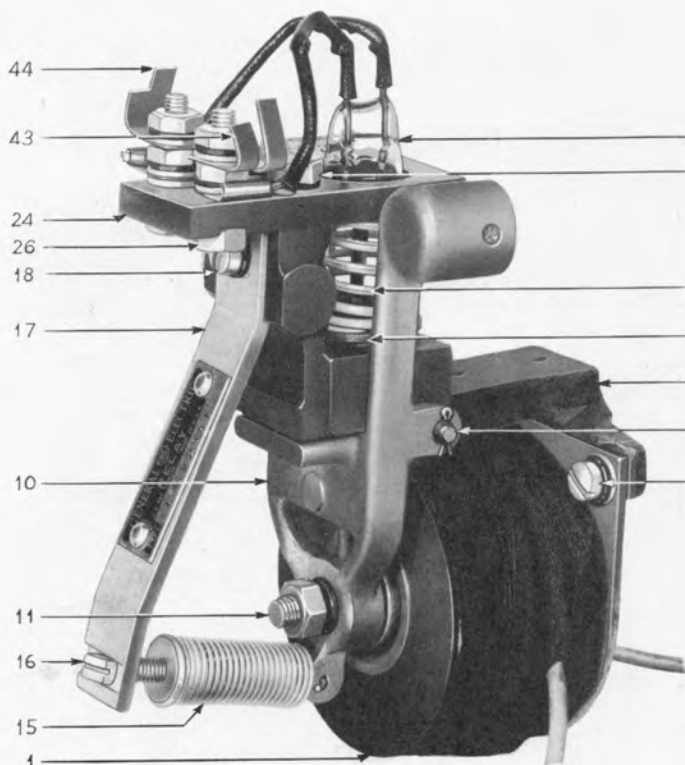

(PHOTO 811402) Type 17LV23A relay

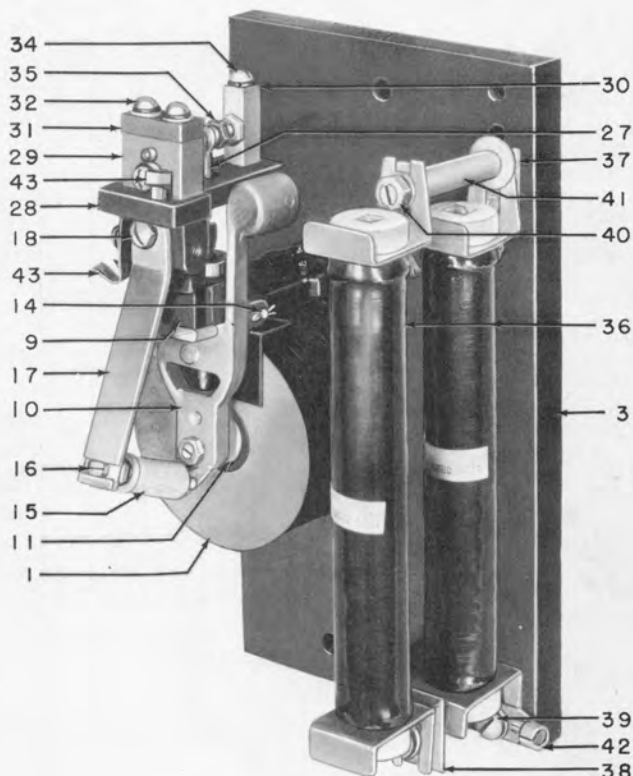

Type 17LV23D relay (PHOTO 814349)

NOTE: The last number in the nameplate rating is the coil number.

EXAMPLE: Type 17LV23A1 indicates that operating coil Cat. No. 2738597 is required.

Ref. No. 1 - OPERATING COILS - (1 Required)

Coil No.	Cat. No.	Coil No.	Cat. No.	Coil No.	Cat. No.	Coil No.	Cat. No.
1	2738597	3	2738594	6	2738687	8	2738794
2	2738656	5	2738744	7	2738767	12	4739154

† The Type 17LV23A Relay may be changed to Type 17LV23J, having an improved type of air brake contacts, by ordering a set of parts Cat. No. 4759735.

When ordering renewal parts, give quantity, catalog number, description of each item required, and complete nameplate reading.



TYPE 17LV23 RELAY

Ref. No. 1 - OPERATING COILS - (1 Required) (CONT'D)

Coil No.	Cat. No.	Coil No.	Cat. No.	Coil No.	Cat. No.	Coil No.	Cat. No.
13	4739164	21	4739245	29	4739293	37	4739480
14	4739165	22	4739246	30	4739303	38	4739409
16	2738596	24	4739267	33	4739375	39	4739409
17	4739204	25	4739268	34	4739376	40	8827064
18	4739217	26	4739271	35	4739443	41	9960905
19	4739236	27	4739272	36	4739409	42	9960944
20	4739244	28	4739273				

Ref. No.	Number Required for Type 17LV23-														Cat. No.	Description
	†A	D	E	J	K	L	M	R	T	Y	AA	AC	AD			
2		2													N37P16006B	Screw fastening terminal to operating coil, 10-32, 3/8 in. r. h.
					2										N37P16006B	Screw fastening terminal to operating coil, 10-32, 3/8 in. r. h. for Type 17LV23J2 and -J25 Relays only
2															4731833P4	Screw fastening terminal to operating coil, for Type 17LV23J29 Relay only
		1													6702873	Spacer between operating coil and base
3	2		2	2	2	2	2	2	2	2	2	2			N44P16006B	Screw fastening operating coil to frame, 10-32, 3/8 in. fil. h.
		2													N44P16016B	Screw fastening operating coil to base, 10-32, 1 in. fil. h.
3															1 9963061P1	Support for operating coil
															2 8817370	Spacer for coil support
4															2 N37P16032B	Screw fastening support to frame, 10-32, 2 in. r. h.
		1							1						4735772	Base
5										1					6712030	Base
		1													6713240	Base
6															8802702	Base
															6703228	Insulation shield for base
6															6713241	Insulation shield for base
															8802703	Insulation shield for base
6															4731833P12	Screw fastening terminal to base, 10-32
			1												6703211	Mounting strap
6															488A675G1	Mounting support with rubber bumper
															6713978	Rubber bumper
6															6711521	Support holding frame in position
															N51P14006B	Screw fastening mounting strap to frame support, 8-36, 3/8 in. f. h.
6															152X49	†Vibration dampener with spacer
															8823840	†Vibration dampener
															8803787	†Metal spacer for vibration dampener

† The Type 17LV23A Relay may be changed to Type 17LV23J, having an improved type of air break contacts, by ordering a set of parts Cat. No. 4759735.

† The Type 17LV23L Relays have been furnished with two different interchangeable designs of vibration dampener. The first design which will no longer be furnished was made of rubber. The second design is a steel spring. For a first replacement of the rubber vibration dampener Cat. 152X49 should be ordered. Thereafter the parts may be ordered separately.

TYPE 17LV23 RELAY

GEF-2907F

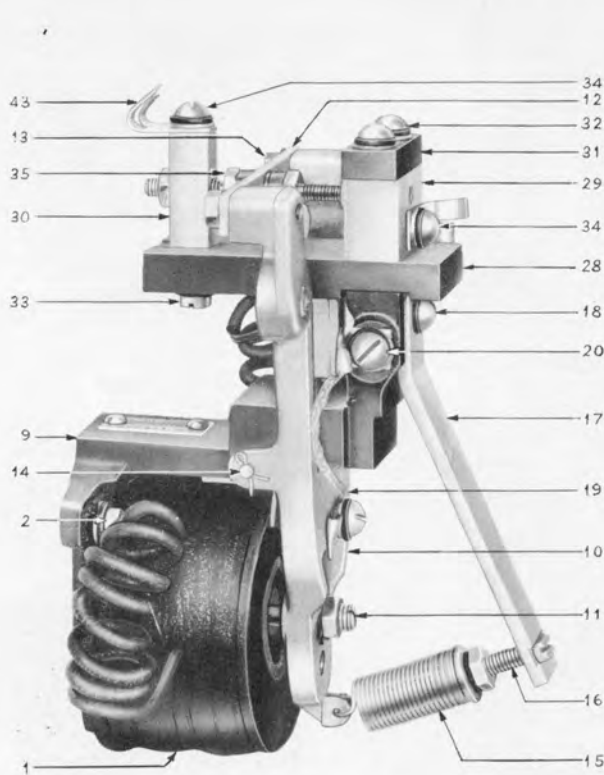

(PHOTO 815972) Type 17LV23J relay

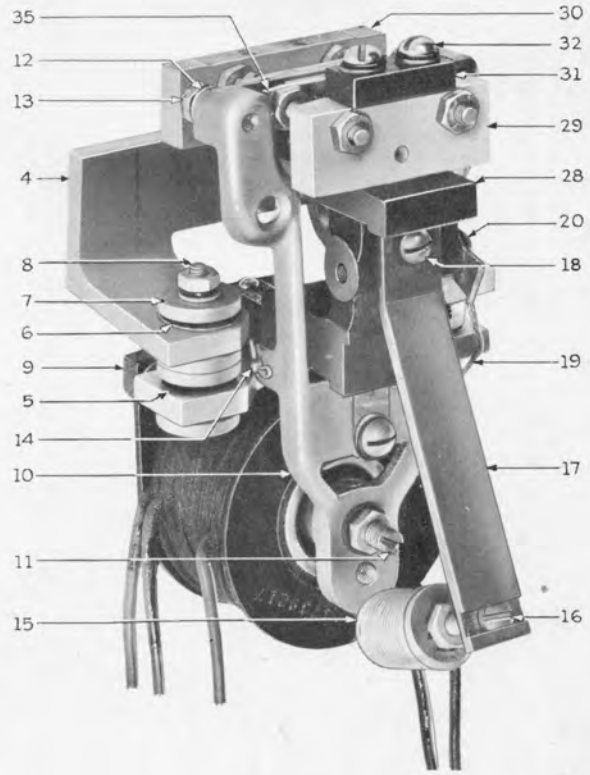

Type 17LV23L relay (PHOTO 817288)

Ref. No.	Number Required for Type 17LV23-														Cat. No.	Description
	A	D	E	J	K	L	M	R	T	Y	AA	AC	AD			
7						8									6711524	Insulation spacer for vibration dampener
8						2									N37P14024B	Screw fastening support to mounting strap, 8-36, 1 1/2 in. r. h.
9	1		1												4734784G1	Frame with coil guard
9		1													4758099	Frame with insulation
9				1	1		1	1	1		1	1	1		6742350P2	Frame
9						1									114X14	Frame with rubber bumper
9						1									6742350P1	Frame
															6713978	Rubber bumper for frame
		2							2						N26P21010B	Bolt fastening frame to base, 1/4 in. -20, 5/8 in. hex. h. sl.
															N37P21012B	Screw fastening frame to base, 1/4 in. -20, 3/4 in. r. h.
			2												N51P21008B	Screw fastening frame to mounting strap, 1/4 in. -20, 1/2 in. f. h.
	1		1	1	1	1	1	1	1	1	1	1	1		4715057	Fixed core for operating coil
		1													4714933	Fixed core for operating coil
			1	1	1	1	1	1	1	1	1	1	1		N51P16012B	Screw fastening fixed core to frame, 10-32, 3/4 in. f. h.
				1											N51P16014B	Screw fastening fixed core to frame, 10-32, 7/8 in. f. h.
10	1		1												4756997	Armature lever with bushings and core (balanced)

† The Type 17LV23A Relay may be changed to Type 17LV23J, having an improved type of air break contacts, by ordering a set of parts Cat. No. 4759735.

TYPE 17LV23 RELAY

Ref. No.	Number Required for Type 17LV23-														Cat. No.	Description
	A	D	E	J	K	L	M	R	T	Y	AA	AC	AD			
10		1													4757000	Armature lever with bushings and core (balanced)
10				1				1							114X15	Armature lever with bushings, core, and contact bar
10					1							1			114X16	Armature lever with bushings, core, and contact bar
10						1		1	1	1			1		114X17	Armature lever with bushings, core, and contact bar (balanced)
10						1									143X68	Armature lever with bushings, core, and contact bar (balanced)
												1			164X78	Armature lever with bushings, core, and contact bar
	1		1												2744723G6	Armature lever with bushings (not balanced)
		1													2744723G2	Armature lever with bushings (not balanced)
				1	1	1	1	1	1	1	1	1	1	1	4746685G1	Armature lever with bushings (not balanced)
	2	2	2	2	2	2	2	2	2	2	2	2	2	2	4711227	Bushing for armature lever
11	1		1	1	1		1	1	1	1	1	1	1	1	4715969	Armature core, 1/4 in. -28
11		1													4714931	Armature core, 1/4 in. -28
11						1									8800506	Armature core, 1/4 in. -28
12					1		1	1	1	1			1		6703976	Contact bar with tips
12				1		1	1	1	1	1				1	6711522	Contact bar
12											1			2	487A730G1	Contact bar with contact tip
											2				8801399	Spacer for contact bar
13				2	2			2			2	2			4731833P6	Screw fastening contact bar to armature lever
13						2	2		2	2				2	4765697P6	Screw fastening contact bar to armature lever
14	1	1	1	1	1	1	1	1	1	1	1	1	1	1	6721901P20	Hinge pin for armature lever
15	1		1				1	1	1				1	1	4731907	Tension spring with plug for armature
15		1													4735901	Tension spring with plug for armature
15					1										4735944	Tension spring with plug for armature
15						1				1					6721257	Tension spring with plug for armature
15				1											4734976	Tension spring with plug for armature
15											1				8823832	Tension spring with plug for armature
16	1	1	1		1	1	1	1	1	1	1	1	1	1	4711454	Adjusting screw for tension spring, 10-32
16				1											4708775	Adjusting screw for tension spring, 10-32
17	1	1	1	1	1	1	1	1	1	1	1	1	1	1	6700258	Bracket for tension spring
						1				1					6712187	Spacer between bracket and frame
18	1	1	1												N44P16006B	Screw fastening spring bracket to frame, 10-32, 3/8 in. fil. h.
18				1	1	1	1	1	1	1	1	1	1	1	N37P16008B	Screw fastening spring bracket to frame, 10-32, 1/2 in. r. h.

† The Type 17LV23A Relay may be changed to Type 17LV23J, having an improved type of air break contacts, by ordering a set of parts Cat. No. 4759735.

TYPE 17LV23 RELAY

GEF-2907F

Ref. No.	Number Required for Type 17LV23-													Cat. No.	Description
	A	D	E	J	K	L	M	R	T	Y	AA	AC	AD		
19				1	1	1	1	1	1	1	1	1	1	4712374	Shunt with terminals for armature and frame
20	1	2	2	3	3	3	3	3	3	3	3	3	3	N44P16006B	Screw fastening terminal to frame, 10-32, 3/8 in. fil. h.
21	1													4711251	Vacuum contact tube
22	1													4769786	Compression spring for vacuum contact tube
23	1													4711217	Spring seat for compression spring
24	1													4711221	Clamping plate for compression spring
25	2													4765696P8	Screw fastening clamping plate to frame
26	2													4765696P12	Screw fastening terminals to clamping plate
27		1	1											6701986	Movable contact arm with support and shunt
		1	1											N37P12004B	Screw for shunt, 6-40, 1/4 in. r. h.
		1	1											N70PC1606	Set screw for movable contact arm, 10-32, 1/2 in. hex. soc. cone pnt.
28		1												6702883	Supporting plate for contact posts
28			1											6701993	Supporting plate for contact posts
28				1	1			1	1		1	1		6703975	Supporting plate for contact posts
28						1	1			1			1	6703975AC	Supporting plate for contact posts
29		1	1	1	1			1	1		1	1		6701997	Large contact post
29						1	1			1			1	6710863	Large contact post
30		1	1	1	1			1	1		1	1		6701994	Small contact post
30						1	1						1	6710862	Small contact post
30										1				6715958	Small contact post
31		1	1	1	1	1	1	1	1	1	1	1	1	6701996	Insulation block for large contact post
32		2	2	2	2	2	2	2	2	2	2	2	2	N37P16026B	Screw fastening large contact post and supporting plate to frame, 10-32, 1 5/8 in. r. h.
		2	2	2	2	2	2	2	2	2	2	2	2	9964850P62	Insulation tube for Cat. 54X260
33		1	1											N37P16008B	Screw fastening small contact post to supporting plate, 10-32, 1/2 in. r. h.
33				1	1	2	2	1	1	2	1	1	2	4731833P7	Screw fastening small contact post to supporting plate, 10-32
34		1	1	1	1	2	2	1	1	2	1	1	2	N37P16006B	Screw fastening terminal to contact post, 10-32, 3/8 in. r. h.
			2											4731833P8	Screw fastening terminal to supporting plate
35		2	2		2							2		185V397	Stationary contact
35				2				2	2				2	6711872	Stationary contact
35						2	2			2			2	6710867	Stationary contact
35		1	1								2			487A729G1	Stationary contact
														6702050	Spacing washer for stationary contact

† The Type 17LV23A Relay may be changed to Type 17LV23J, having an improved type of air break contacts, by ordering a set of parts Cat. No. 4759735.

TYPE 17LV23 RELAY

Ref. No.	Number Required for Type 17LV23-														Cat. No.	Description		
	A	D	E	J	K	L	M	R	T	Y	AA	AC	AD					
36		2														9948378G75	Resistor Unit, 1200 ohms	
36															1	9948377G80	Resistor Unit, 10,000 ohms, for Type 17LV23AC38 only	
36															1	9948377G78	Resistor Unit, 8000 ohms, for Type 17LV23AC39 only	
37		2													2	1451409	Connection block for resistor unit	
38		1														4704977	Support for outer resistor unit	
39		6													4	N37P21008B	Screw fastening resistor unit, connection block, or support in position, 1/4 in. -20, 1/2 in. r.h.	
40		1														N37P21040B	Screw fastening resistor units in position, 1/4 in. -20, 2 1/2 in. r.h.	
41		1														4704862	Spacer for Cat. N37P21040B	
																2738971G1	Cover with fastener	
																87X24	Fastener for cover (Dzus Fastener Co. A5-40)	
																87X32	Grommet for fastener (Dzus Fastener Co. GA5-375)	
																6724861G1	Support with spring catch, for cover	
																4757154	Spring catch with rivets, for support	
																2	N26P21012B	Bolt fastening cover support to base, 1/4 in. -20, 3/4 in. hex. h. sl.

† The Type 17LV23A Relay may be changed to Type 17LV23J, having an improved type of air break contacts, by ordering a set of parts Cat. No. 4759735.

TERMINALS

Ref. No.	Cat. No.	Description
	417591	Tinned copper terminal, straight (0.200 in. bolt hole)
42	416575	Tinned copper terminal, straight (17/64 in. bolt hole)
43	410567	Tinned copper terminal, flag type, left-hand (0.200 in. bolt hole)
44	434048	Tinned copper terminal, flag type, right-hand (0.200 in. bolt hole)
	414567	Tinned copper terminal, flag type, right-hand (17/64 in. bolt hole)
43	282X68	Solderless terminal (Thomas & Betts Co. B-36G)

NOTE: The following items are steel unless otherwise specified.

PLAIN WASHERS

Cat. No.	Description
N402P7B	For No. 6 screw
N402P8B	For No. 8 screw
N402P9B	For No. 10 screw
N402P11B	For 1/4 in. screw, 1/2 in. O.D.
N402P41B	For 1/4 in. screw, 3/4 in. O.D.

LOCK WASHERS

Cat. No.	Description
N405P37P	For No. 6 screw
N405P38P	For No. 8 screw
N405P39P	For No. 10 screw, regular
N403P19P	For No. 10 screw, external teeth
N409P13P	For No. 10 screw, csk
N404P19P	For No. 10 screw, internal teeth
N405P41P	For 1/4 in. screw, regular
N403P25P	For 1/4 in. screw, external teeth
N409P15P	For 1/4 in. screw, csk

NUTS

N210P14B	8-36, hex. std
N210P16B	10-32, hex. std
N211P20	1/4 in. -28, hex., jam, brass

COTTER PIN

N503P405B	3/64 in. by 5/16 in.
-----------	----------------------

INDEX OF CATALOG NUMBERS

Catalog identifications in this index are arranged in order, reading from left to right, first alphabetically according to the prefix letter or letters, if used, and second numerically.

In this index all numbers with a letter prefix will precede those without prefixes.

The number of letters or digits does not affect placement in the table, thus A1999999 will precede A2, and ZZ9999999 will precede Cat. No. 1 (number without a prefix). Letters take precedence over numbers so that Cat. No. 26F1 will precede Cat. No. 261.

Catalog Number	Page	Catalog Number	Page	Catalog Number	Page	Catalog Number	Page
N210P14B	6	152X49	2	4735944	4	6702873	2
N210P16B	6	164X78	4	4739154	1	6702883	5
N211P20	6	185V397	5	4739164	2	6703211	2
N26P21010B	3	2738594	2	4739165	2	6703228	2
N26P21012B	6	2738596	1	4739204	2	6703975	5
N37P12004B	5	2738597	1	4739217	2	6703975AC	5
N37P14024B	3	2738656	1	4739236	2	6703976	4
N37P16006B	2, 5	2738687	1	4739244	2	6710862	5
N37P16008B	4, 5	2738744	1	4739245	2	6710863	5
N37P16026B	5	2738767	1	4739246	2	6710867	5
N37P16032B	2	2738794	1	4739267	2	6711521	2
N37P21008B	6	2738971G1	6	4739268	2	6711522	4
N37P21012B	3	2744723G2	4	4739271	2	6711524	3
N37P21040B	6	2744723G6	4	4739272	2	6711872	5
N402P11B	6	282X68	6	4739273	2	6712030	2
N402P41B	6	410567	6	4739293	2	6712187	4
N402P7B	6	416575	6	4739303	2	6713240	2
N402P8B	6	417591	6	4739375	2	6713241	2
N402P9B	6	434048	6	4739376	2	6713978	2, 3
N403P19P	6	4704862	6	4739409	2	6715958	5
N403P25P	6	4704977	6	4739443	2	6721257	4
N404P19P	6	4708775	4	4739480	2	6721901P20	4
N405P37P	6	4711217	5	4746685G1	4	6724861G1	6
N405P38P	6	4711221	5	4756997	3	6742350P1	3
N405P39P	6	4711227	4	4757000	4	6742350P2	3
N405P41P	6	4711251	5	4757154	6	87X24	6
N409P13P	6	4711454	4	4758099	3	87X32	6
N409P15P	6	4712374	5	4759735	2, 4, 5	8800506	4
N44P16006B	2, 4, 5	4714931	4	4765696P12	5	8801399	4
N44P16016B	2	4714933	3	4765696P8	5	8802702	2
N503P405B	6	4715057	3	4765697P6	4	8802703	2
N51P14006B	2	4715969	4	4769786	5	8803787	2
N51P16012B	3	4731833P12	2	487A729G1	5	8817370	2
N51P16014B	3	4731833P4	2	487A730G1	4	8823832	4
N51P21008B	3	4731833P6	4	488A675G1	2	8823840	2
N70PC1606	5	4731833P7	5	6700258	4	8827064	2
114X14	3	4731833P8	5	6701986	5	9948377G78	6
114X15	4	4731907	4	6701993	5	9948377G80	6
114X16	4	4734784G1	3	6701994	5	9948378G75	6
114X17	4	4734976	4	6701996	5	9960905	2
143X68	4	4735772	2	6701997	5	9960944	2
1451409	6	4735901	4	6702050	5	9963061P1	2
						9964850P62	5

WHEN YOU NEED SERVICE

IF YOU NEED TO REPAIR, recondition, or rebuild any electric apparatus, a G-E service shop near you is available day and night, seven days a week, for work in the shops or on your premises. Latest factory methods and genuine G-E renewal parts are used to maintain the original performance of your G-E equipment. For full information about these services, contact the nearest service shop or sales office listed below:

APPARATUS SERVICE SHOPS

Appleton, Wisc. Midway Industrial Area,
County Trunk, "P"
Atlanta—Chamblee, Ga. 4639 Peachtree
Indus. Blvd.
Baltimore 30, Md. 920 E. Fort Ave.
Boston—Medford 55, Mass. Mystic Valley Pkwy.
Buffalo 11, N. Y. 318 Urban St.
Charleston 28, W. Va. 306 MacCorkle Ave., S.E.
Charlotte, N. C. 2328 Thrift Road
Chicago 32, Ill. 4360 W. 47th St.
Cincinnati 2, Ohio 444 W. Third St.
Cleveland 4, Ohio 4966 Woodland Ave.
Columbus 23, Ohio 2128 Eakin Rd.
Dallas 9, Texas 3202 Manor Way
Davenport—Bettendorf, Ia. 1039 State St.
Decatur, Ill. 2225 E. Logan St.
Denver 5, Colo. 3353 Larimer St.
Detroit 2, Mich. 5950 Third Ave.
Houston 20, Texas 5534 Harvey Wilson Drive
Indianapolis, Ind. 1740 W. Vermont St.
Johnstown, Pa. 841 Oak St.
Kansas City 8, Mo. 819 E. 19th St.
Los Angeles 1, Calif. 6900 Stanford Ave.
Louisville, Ky. 2014 New Main St.
Midland, Tex. 3404 Bankhead Hwy.
Milwaukee 3, Wisc. 940 W. St. Paul Ave.
Minneapolis 12, Minn. 2025 49th Ave., N.
New York 14, N. Y. 416 W. 13th St.
Philadelphia 23, Pa. 1040 E. Erie Ave.
Pittsburgh 6, Pa. 6519 Penn Ave.
Portland 18, Oregon 2727 N.W. 29th Ave.
Richmond 24, Va. 1403 Ingram Ave.
St. Louis 10, Mo. 1115 East Road
Salt Lake City 4, Utah 301 S. Seventh West St.
San Francisco 3, Calif. 1098 Harrison St.
Seattle 4, Wash. 3422 First Ave., S.
Spokane 3, Wash. S. 155 Sherman St.
Toledo 4, Ohio 1 So. St. Clair St.
York, Pa. 54 N. Harrison St.
Youngstown 5, Ohio 272 E. Indianola Ave.

APPARATUS SALES OFFICES

Abilene, Texas 442 Cedar St.
Akron 8, Ohio 335 S. Main St.
Albany 7, N. Y. 90 State St.
Albuquerque, N. Mex. 323 Third St., S.W.
Alexandria, La. 720 Murray St.
Allentown, Pa. 1132 Hamilton St.
Amarillo, Texas 402 Amarillo Bldg.
Appleton, Wisc. 531 W. College Ave.
Atlanta 3, Ga. 1860 Peachtree Rd., N.W.
Augusta, Ga. 423 Masonic Bldg.
Augusta, Me. 15 Grove St.
Baltimore 1, Md. 111 Park Ave.
Bangor, Maine 77 Central St.
Baton Rouge 6, La. 3170 Florida Blvd.
Battle Creek, Mich. 25 W. Michigan Ave.
Beaumont, Texas 1385 Calder Ave.
Billings, Mont. Rm. 816, 303 No. Broadway
Binghamton, N. Y. 19 Chenango St.
Birmingham 3, Ala. 1804 Seventh Ave., N.
Bismarck, N. Dak. 418 Rosser Ave.
Bluefield, W. Va. P.O. Box 447, Appalachian Bldg.
Boise, Idaho 1524 Idaho St.
Boston 1, Mass. 140 Federal St.
Buffalo 3, N. Y. 535 Washington St.
Butte, Mont. P.O. Box 836, 103 N. Wyoming St.
Canton 2, Ohio 700 Tuscarawas St., W.
Cedar Rapids, Iowa 210 Second St., S.E.
Charleston 28, W. Va. 306 MacCorkle Ave., S.E.
Charlotte 1, N. C. 112 S. Tryon St.
Chattanooga 2, Tenn. 832 Georgia Ave.
Chicago 80, Ill. P.O. Box 5970A, 840 S. Canal St.
Cincinnati 2, Ohio 215 W. Third St.
Cleveland 4, Ohio 4966 Woodland Ave.
Columbia 1, S.C. P.O. Box 1434, 1420 Lady St.
Columbus 15, Ohio 40 S. Third St.
Corpus Christi, Texas 205 N. Chaparral
Dallas 2, Texas 1801 N. Lamar St.
Davenport—Bettendorf, Ia. 1039 State St.
Dayton 2, Ohio 11 W. Monument Bldg.



For service outside the United States, Canada, and Hawaii, consult the nearest office of the International General Electric Company.

Denver 2, Colo. 650 Seventeenth St.
Des Moines 9, Iowa 505 W. Fifth Ave.
Detroit 2, Mich. 700 Antoinette St.
Duluth 2, Minn. 14 W. Superior St.
Elmira, N. Y. Main and Woodlawn Aves.
El Paso, Texas 215 No. Stanton
Erie, Pa. 1001 State St.
Eugene, Ore. 610 High St.
Evansville 19, Ind. 123 N.W. Fourth St.
Fairmont, W. Va. 310 Jacobs Bldg.,
P.O. Box 1626
Fergus Falls, Minn. 108 N. Court Ave. P.O. Box 197
Flint 3, Mich. 653 S. Saginaw St.
Fort Wayne 6, Ind. 3606 So. Calhoun
Fort Worth 2, Texas 408 W. Seventh St.
Fresno 1, Calif. 407 Patterson Bldg.
Tulare and Fulton St.
Grand Rapids 2, Mich. 148 Monroe Ave., N.W.
Greensboro, N. C. 301 S. Elm St.
Greenville, S. C. 108 W. Washington St.
Gulfport, Miss. 207 Jo-Fran Bldg.
Hagerstown, Md. Professional Arts Bldg.
Hartford 3, Conn. 410 Asylum St.
Houston 1, Texas 1312 Live Oak St.
Indianapolis 4, Ind. 110 N. Illinois St.
Jackson, Mich. 120 W. Michigan Ave.
Jackson 1, Miss. 203 W. Capitol St.
Jacksonville 2, Fla. 700 E. Union St.
Jamestown, N. Y. P.O. Box 548, 2 Second St.
Johnson City, Tenn. 321-323 W. Walnut St.
Johnstown, Pa. 841 Oak St.
Joplin, Mo. P.O. Box 948, 220 1/2 W. Fourth St.
Kalamazoo 3, Mich. 112 Parkway Ave.
Kansas City 6, Mo. 106 W. Fourteenth St.
Knoxville 08, Tenn. 602 S. Gay St.
Lansing 8, Mich. 306 Michigan National Tower
Lexington, Ky. First National Bank Bldg.
Lincoln 8, Nebr. Sharpe Bldg., 206 S. 13th St.
Little Rock, Ark. 103 W. Capitol Ave.
Los Angeles 54, Calif. 212 N. Vignes St.
Louisville 2, Ky. 455 S. Fourth St.
Macon, Ga. 682 Cherry St.
Madison 3, Wisc. 16 N. Carroll St.
Manchester, N. H. 875 Elm St.
Medford, Ore. P.O. Box 1349, 205 W. Main St.
Memphis 3, Tenn. 8 N. Third St.
Miami 32, Fla. 25 S.E. Second Ave.
Milwaukee 3, Wisc. 940 W. St. Paul Ave.
Minneapolis 3, Minn. 12 S. Sixth St.
Mobile 13, Ala. 54 St. Joseph St.
Nashville 3, Tenn. 234 Third Ave., N.
Newark 2, N. J. 744 Broad St.
New Haven 6, Conn. 129 Church St.
New Orleans 12, La. 837 Gravier St.
New York 22, N. Y. 570 Lexington Ave.
Niagara Falls, N. Y. 253 Second St.

Norfolk 10, Va. 229 W. Bute St.
Oakland 12, Calif. 409 Thirteenth St.
Oklahoma City 2, Okla. 119 N. Robinson St.
Omaha 2, Nebr. 409 S. Seventeenth St.
Pasco, Wash. 421 W. Clark St.
Peoria 2, Ill. 309 Jefferson Bldg.
Philadelphia 2, Pa. 1405 Locust St.
Phoenix, Ariz. P.O. Box 4037, 303 Luhrs Tower
Pittsburgh 22, Pa. The Oliver Bldg., Mellon Sq.
Portland 7, Ore. 920 S.W. Sixth Ave.
Providence 3, R. I. Industrial Trust Bldg.
Raleigh, N. C. 336 Fayetteville St.
Reading, Pa. 31 N. Sixth St.
Richmond 17, Va. 700 E. Franklin St.
Riverside, Calif. 3570 Ninth St.
Roanoke 16, Va. 920-924 S. Jefferson St.
Rochester 4, N. Y. 89 E. Ave.
Rockford, Ill. 110 S. First St.
Rutland, Vt. 38 1/2 Center St.
Sacramento 14, Calif. 626 Forum Bldg.
Saginaw, Mich. Second National Bank Bldg.
St. Louis 1, Mo. 818 Olive St.
Salt Lake City 9, Utah 200 S. Main St.
San Antonio 5, Texas 434 So. Main Ave.
San Diego 1, Calif. 1240 Seventh Ave.
San Francisco 6, Calif. 235 Montgomery St.
San Jose 10, Calif. 460 Park Ave.
Savannah, Ga. 4 E. Bryan St.
Seattle 4, Wash. 710 Second Ave.
Shreveport, La. 910 Shelby Bldg.
Sioux City 13, Iowa 572 Orpheum Electric Bldg.
Sioux Falls, S. D. 306 South Phillips Ave.
South Bend 1, Ind. 112 W. Jefferson Blvd.
Spokane 4, Wash. S. 162 Post St.
Springfield, Ill. 607 E. Adams St.
Springfield 3, Mass. 1387 Main St.
Stockton, Calif. 11 So. San Joaquin St.
Syracuse 2, N. Y. 113 S. Salina St.
Tacoma 1, Wash. 1202 Washington Bldg.
Tampa 6, Fla. 1206 North A St.
Toledo 4, Ohio 420 Madison Ave.
Trenton 8, N. J. 214 E. Hanover St.
Tucson, Ariz. P.O. Box 710, 650 N. Sixth Ave.
Tulsa 3, Okla. 320 S. Boston Ave.
Utica 2, N. Y. 258 Genesee St.
Washington 5, D.C. 777-14th St., N.W.
Waterbury 89, Conn. 111 W. Main St.
Waterloo, Iowa 206 W. 4th St.
Wenatchee, Wash. 328 N. Wenatchee Ave.
Wheeling, W. Va. 40 Fourteenth St.
Wichita 2, Kan. 200 E. First St.
Williamston, N. C. 115 E. Main St.
Worcester 5, Mass. 288 Grove St.
York, Pa. 54 N. Harrison St.
Youngstown 5, Ohio 272 E. Indianola Ave.

Hawaii: American Factors, Ltd., P. O. Box 3230, Honolulu 1 Canada: Canadian General Electric Company, Ltd., Toronto

LOCOMOTIVE AND CAR EQUIPMENT DEPARTMENT, GENERAL ELECTRIC COMPANY, ERIE, PA.



RENEWAL PARTS

TYPE GMG-140 EXCITER-AUXILIARY GENERATOR

Model Numbers

5GMG140A1
5GMG140B1

5GMG140A2
5GMG140C1

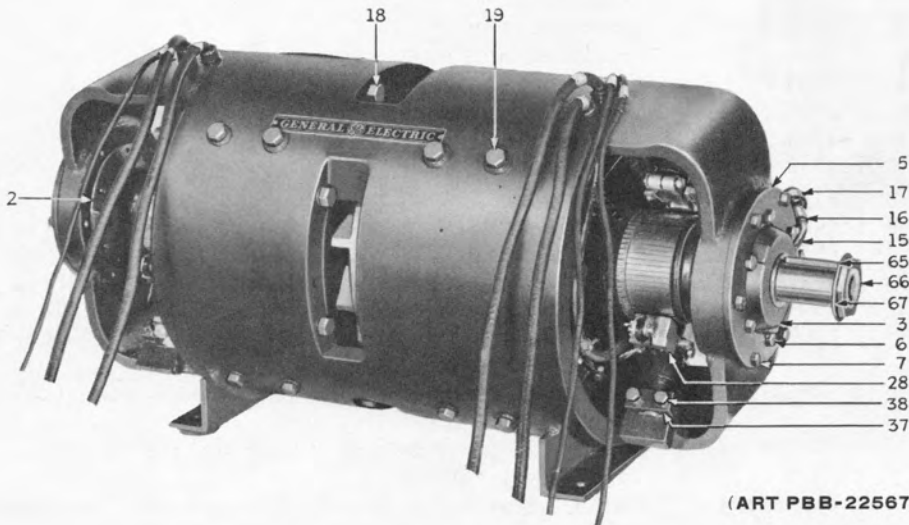
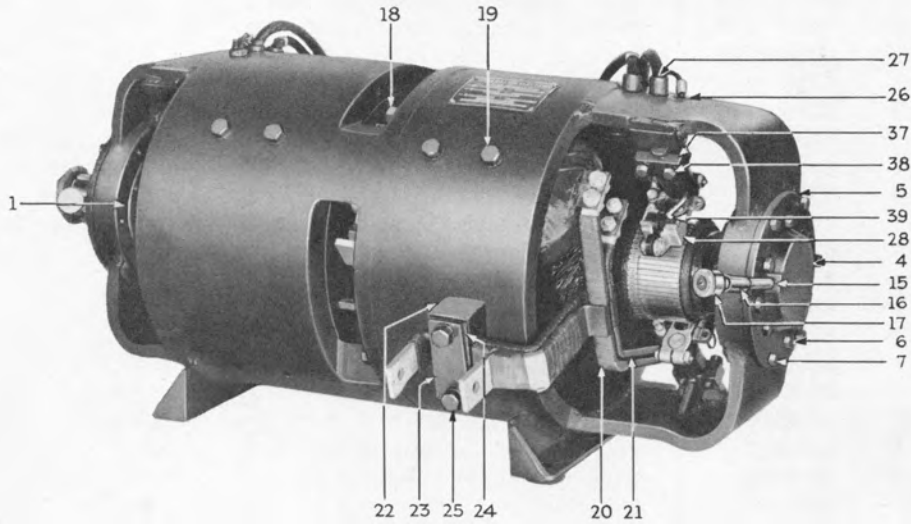

(ART PBB-22567)

Type GMG-140-A1 exciter-auxiliary generator

(Reference numbers are identified in listings beginning on page 2)

When ordering renewal parts, give quantity, catalog number, description of each item required, and complete nameplate reading.



TYPE GMG-140 EXCITER-AUXILIARY GENERATOR

Ref. No.	No. Req. for Model 5GMG140				Cat. No.	Description
	A1	A2	B1	C1		
			1		6744330G1	Commutator inspection cover, generator end
				1	6744516G2	Commutator inspection cover, generator end
			1		6744330G2	Commutator inspection cover, exciter end
				1	6744516G1	Commutator inspection cover, exciter end
			8		20X529	Screw fastening cover in position, 1/4 in. -20
				4	144972	Screw fastening cover in position, 3/8 in. -16
			8		6X825	Lock washer, 1/4 in.
				4	54X553	Lock washer, 3/8 in.
1	1	1	1	1	4732845P2	Bearing housing, generator end
2	1	1	1	1	6726075P1	Bearing housing, exciter end
3	1	1	1	1	6726084P1	Bearing cap, generator end
4	1	1	1	1	6726074P1	Bearing cap, exciter end
5	2	2	2	2	6726073P1	End plate for bearing housing and cap
	1	1	1	1	8806965P1	Gasket between bearing housing and cap, generator end
	4	4	4	4	180937	Screw fastening bearing cap to bearing housing, 10-32
6	12	12	12	12	158092	Screw fastening bearing housing and cap to end plate, 3/8 in. -16
7	12	12	12	12	128968	Screw fastening end plate to magnet frame, 3/8 in. -16
	24	24	24	24	54X553	Lock washer, 3/8 in.
8	1	1	1	1	8864950P81	BALL BEARING, generator end
9	1	1	1	1	8864950P53	Ball bearing, exciter end
10	2	2	2	2	6704604	Lubricant flinger, generator end
11	1	1	1	1	8806980P1	Lubricant flinger, exciter end
12	1	1	1	1	8806987P1	Spacing collar back of ball bearing, exciter end
13	1	1	1	1	8806989P1	Retaining collar for ball bearing, generator end
14	1	1	1	1	4701839	Retaining nut for ball bearing, exciter end
	1	1	1	1	6705352	Lock washer for retaining nut
15	2	2	2		6705219	Lubricant pipe
16	2	2	2		248642	Coupling for lubricant pipe
17	2	2	2		294121	Grease cup
				2	227X43	Lubricant fitting
18	8	8	8	8	265042	Screw fastening magnet frames together, 1/2 in. -13
	8	8	8	8	54X547	Lock washer, 1/2 in.
	2	2	2	2	4729539G1	Laminated pole piece for auxiliary generator
	2		2	2	4748328G1	Laminated pole piece for exciter
			2		4748498G1	Laminated pole piece for exciter
	2	3	2	3	4729541G1	Commutating pole piece
	2				4729140P4	Shim for exciter laminated pole piece, steel (0.014 in. thick)
		4			6705366	Shim for exciter laminated pole piece, brass (0.010 in. thick)
		2		2	4729140P6	Shim for exciter laminated pole piece, steel (0.019 in. thick)
				2	8804174P1	Shim for exciter laminated pole piece, steel (0.007 in. thick)
	1		1		8805111P1	Shim for auxiliary generator commutating pole piece, brass (0.030 in. thick)
		4		4	6705654P1	Shim for auxiliary generator commutating pole piece, steel (0.007 in. thick)
			2		4729140P4	Shim for auxiliary generator laminated pole piece, steel (0.014 in. thick)
			2		8805152P1	Shim for auxiliary generator laminated pole piece, steel (0.010 in. thick)
			2		8805176P1	Shim for auxiliary generator laminated pole piece, brass (0.005 in. thick)
19	12	14	12	14	188187	Screw fastening pole piece to magnet frame, 1/2 in. -13
	12	14	12	14	54X547	Lock washer, 1/2 in.
	1	1			4729543G1	EXCITING FIELD COIL for auxiliary generator, upper right-hand facing commutator end
			1	1	4729543G1	Exciting field coil for auxiliary generator, lower right-hand facing commutator end
	1	1			4729543G2	Exciting field coil for auxiliary generator, lower left-hand facing commutator end
			1	1	4729543G2	Exciting field coil for auxiliary generator, upper left-hand facing commutator end
	A1	A2	B1	C1		

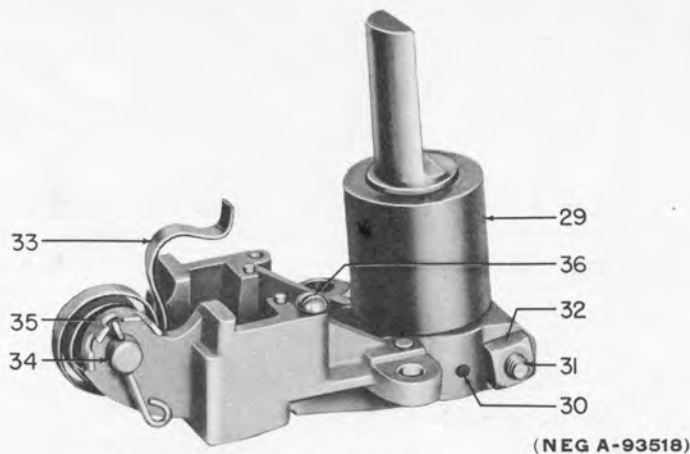

Brush holder Ref. No. 28

Ref. No.	No. Req. for Model 5GMG140				Cat. No.	Description
	A1	A2	B1	C1		
	1	1			6751189G1	Exciting field coil for exciter, upper left-hand facing commutator end
			1		6751189G1	Exciting field coil for exciter, upper right-hand facing commutator end
				1	6751189G4	Exciting field coil for exciter, upper right-hand facing commutator end
	1	1			6751189G2	Exciting field coil for exciter, lower right-hand facing commutator end
			1		6751189G2	Exciting field coil for exciter, lower left-hand facing commutator end
				1	6751189G3	Exciting field coil for exciter, lower left-hand facing commutator end
	1		1		4729545G1	Commutating field coil for auxiliary generator
		2		2	6732864G1	Commutating field coil for auxiliary generator
	1	1	1	1	4729542G1	Commutating field coil for exciter
	2	2	2	2	6726090P1	Pad for exciter exciting field coil
20	1	1			4748354G2	Outer bus ring for exciter exciting field coil
20			1	1	4748354G5	Outer bus ring for exciter exciting field coil
21	1	1			4748354G3	Inner bus ring for exciter exciting field coil
21			1	1	4748354G6	Inner bus ring for exciter exciting field coil
	9	9	9	9	267X30	Terminal for small cable
	8	10	8	10	278X11	Terminal for large cable
	12	14	12	14	20X536	Screw fastening terminal to field coil, 1/4 in. -20
	4	4	4	4	20X527	Screw fastening terminal to brush holder, 1/4 in. -20
	8	8	8	8	133717	Screw fastening bus ring to field coil, 3/8 in. -16
	4	4	4	4	12X540	Nut, 1/4 in. -20, square
	12	14	12	14	1X452	Nut, 1/4 in. -20, hex.
	8	8	8	8	141257	Jam nut, 3/8 in. -16
	12	14	12	14	143974	Washer, 1/4 in.
	8	8	8	8	141259	Washer, 3/8 in.
	16	18	16	18	6X825	Lock washer, 1/4 in.
	8	8	8	8	54X553	Lock washer, 3/8 in.
22	1	1	1	1	6726092P1	Support for bus ring terminal straps
23	1	1	1	1	6705212	Clamping plate for bus ring terminal straps
24	1	1	1	1	6705211	Insulation for clamping plate
25	2	2	2	2	217898	Screw fastening support and clamping plate in position, 1/2 in. -13
	2	2	2	2	54X547	Lock washer, 1/2 in.
26	1	1	1	1	422291	Soft rubber bushing for cable (9/32 in. cable hole)
27	5	5	5	5	421151	Soft rubber bushing for cable (1/2 in. cable hole)
	A1	A2	B1	C1		

∅ Bulk cable is listed at end of text.

TYPE GMG-140 EXCITER-AUXILIARY GENERATOR

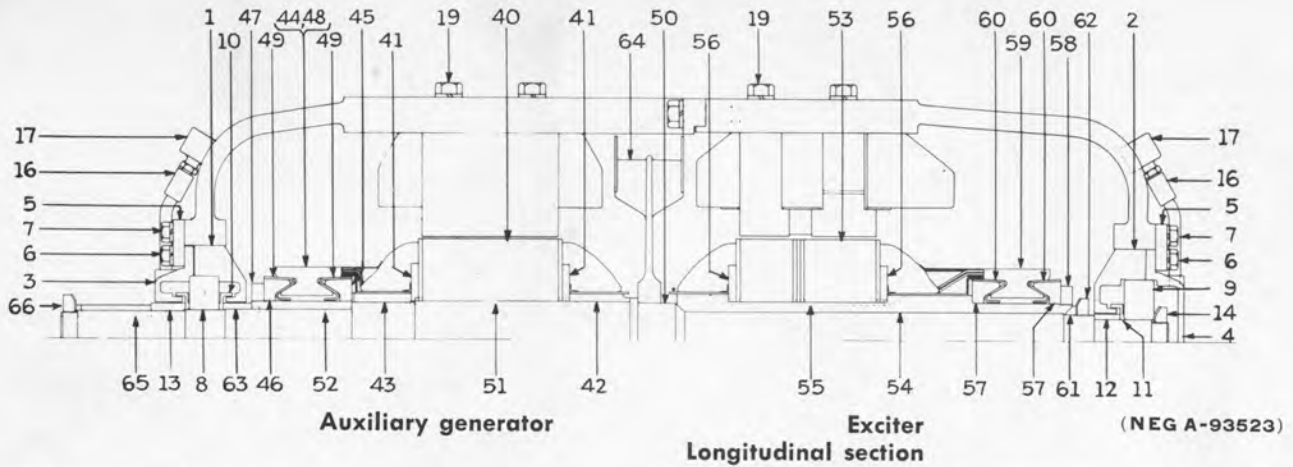

Ref. No.	No. Req. for Model 5GMG140				Cat. No.	Description
	A1	A2	B1	C1		
27	5	5	5	5	8811883	#Soft rubber bushing for cable (7/16 in. cable hole)
28	4	4	4	4	4729589G1	BRUSH HOLDER with insulated stud and pressure arm
29	4	4	4	4	6722012P1	Insulated stud for brush holder
30	4	4	4	4	62342	Pin for stud and body
31	4	4	4	4	20X553	Clamping screw, 1/4 in. -20
32	4	4	4	4	12X540	Nut, 1/4 in. -20
	4	4	4	4	6X825	Lock washer, 1/4 in.
33	4	4	4	4	4763978	Pressure arm for brush holder
34	4	4	4	4	8805105G1	Shaft for pressure arm, with adjusting lever
35	4	4	4	4	3797741	Locking plate for adjusting lever
	4	4	4	4	143497	Cotter pin, 1/16 in. by 1/2 in.
36	4	4	4	4	210187	Binding screw for brush pigtail, 8-36
37	4	4	4	4	4732033P3	Clamp for brush holder
38	8	8	8	8	257581	Screw fastening clamp to magnet frame, 3/8 in. -16
	8	8	8	8	54X553	Lock washer, 3/8 in.
39	4	4	4	4	6722019	CARBON BRUSH with pigtail and terminal
	1	1			6751194G1	ARMATURE with commutators, shaft, and fan
			1	1	6751194G7	Armature with commutators, shaft, and fan
40	1	1	1	1	6751194G6	Auxiliary generator armature, with commutator and shaft
					-----	NOTE:- Auxiliary generator is wound with 0.0571 in. diam bare, 0.0661 in. diam HFG wire requiring approximately 560 feet (5 7/10 lb).
	1	1	1	1	920X88	Set of armature punchings
	180	180	180	180	4720968P1	Main punching, 0.025 in. thick
	2	2	2	2	4720968P2	End punching, 0.125 in. thick
41	2	2	2	2	4701871	Clamping ring for punchings
42	1	1	1	1	8806984P1	Spacing collar, fan end
43	1	1	1	1	8806991P1	Retaining collar for punchings, commutator end
44	1	1	1	1	6726214G1	Commutator for auxiliary generator
45	1	1	1	1	6726078P1	Shell for commutator
46	1	1	1	1	4701899	Cap for commutator
47	1	1	1	1	4701867	Clamping nut for commutator
48	1	1	1	1	4759798	Set of copper and mica auxiliary generator commutator segments, finished and bound
49	2	2	2	2	4701896	Combination inner and outer mica cone, for front or back of commutator
	1	1	1	1	4701898	Insulation ring between commutator and windings
50	1	1	1	1	4729549G1	Shaft with keys for punchings and commutator
	A1	A2	B1	C1		

The above Exciter-Auxiliary Generators have been equipped with two types of insulated cable, the original type being braided cotton insulation will no longer be furnished. When ordering new rubber insulated lead cables as a first replacement, cable bushing (symbol #) must be ordered also. Thereafter cables or rubber bushings may be ordered separately.

Auxiliary Generator

Generator End Bearing

G.E. Part no. 8864950p8I

~~N.H. " " 309-F-G2~~

~~M.R.C. " " 309-SF-T7~~

S.K.F. " " 6309-~~ZJ Q~~

Exciter end

G.E. Part no. 8864950P53

~~S.K.F.B " " N-212-M/04~~

~~M.R.C. " " R-212-CI-T30-46~~

4075F A B C I

0120 A 006 A 8 2 ~~S~~

NEW YORK, ONTARIO AND WESTERN RAILWAY
LEWIS D. FREEMAN, TRUSTEE

NEW YORK, ONTARIO AND WESTERN RAILWAY

LEWIS D. FREEMAN, TRUSTEE

STATION _____ 19____

BILL NO. _____

To NEW YORK, ONTARIO AND WESTERN RAILWAY, DR., FOR CHARGES AS FOLLOWS:

CAR		ORIGINAL CAR		CONTENTS	DATE AND POINT OF SHIPMENT
INITIALS	NUMBER	INITIALS	NUMBER		

CAR DEMURRAGE AND HAZARDOUS OR L. C. L. STORAGE

ARRIVED			NOTICE SENT			ORDERED			CONSTRUCTIVELY PLACED			PLACED			RELEASED			DAYS DETAINED	AMOUNT
MONTH	DATE	HOUR	MONTH	DATE	HOUR	MONTH	DATE	HOUR	MONTH	DATE	HOUR	MONTH	DATE	HOUR	MONTH	DATE	HOUR		

SWITCHING

FROM	TO	WEIGHT	RATE	AMOUNT

AMOUNT

→ FOR _____

→ SHOW SERVICE FOR WHICH BILL IS RENDERED.

ACCOUNTING BUREAU RECORD

generator end

8864950P81

N.H. 309-R-G2 MRC 309-SF-T7

SKF 6309-2-J-

Exciter end

8864950P53

SKF N-212 ~~N-212~~
M/C4

Dave ←

↓
ERIC

MRC R-212-C1-T30-46

343 8928 Part

N. Burg ←

1-201-866-2161

NEW YORK, ONTARIO AND WESTERN RAILWAY

LEWIS D. FREEMAN, TRUSTEE

STATION _____ 19__

BILL NO. _____

TO NEW YORK, ONTARIO AND WESTERN RAILWAY, DR., FOR CHARGES AS FOLLOWS:

CAR		ORIGINAL CAR		CONTENTS	DATE AND POINT OF SHIPMENT
INITIALS	NUMBER	INITIALS	NUMBER		

CAR DEMURRAGE AND HAZARDOUS OR L. C. L. STORAGE

ARRIVED			NOTICE SENT			ORDERED			CONSTRUCTIVELY PLACED			PLACED			RELEASED			DAYS DETAINED	AMOUNT	
MONTH	DATE	HOUR	MONTH	DATE	HOUR	MONTH	DATE	HOUR	MONTH	DATE	HOUR	MONTH	DATE	HOUR	MONTH	DATE	HOUR			

SWITCHING

FROM	TO	WEIGHT	RATE	AMOUNT

AMOUNT

→ FOR _____

→ SHOW SERVICE FOR WHICH BILL IS RENDERED.

STATION RECORD

TYPE GMG-140 EXCITER-AUXILIARY GENERATOR

GEF-2933B

ref. No.	No. Req. for Model 5GMG140				Cat. No.	Description
	A1	A2	B1	C1		
51	1	1	1	1	8806969P1	Key for shaft and punchings
52	1	1	1	1	8806970P1	Key for shaft and commutator
	1	1	1	1	4759278	Set of rewinding insulations and wedges, for auxiliary generator armature
53	21	21	21	21	3922272P76	Wedge for slot
	1	1	1	1	6751194G4	Exciter armature, with commutator (without shaft)
					-----	NOTE:- Exciter armature is wound with 0.068 in. diam bare, 0.077 in. diam HFG wire requiring approximately 425 feet (6 1/4 lb).
	1	1	1	1	920X89	Set of armature punchings
160	160	160	160	160	4720968P1	Main punching, 0.025 in. thick
	6	6	6	6	4720968P2	End or center punching, 0.125 in. thick
54	1	1	1	1	4759279	Armature sleeve with key for punchings
55	1	1	1	1	8806969P1	Key for sleeve and punchings
56	2	2	2	2	4701871	Clamping ring for punchings
	1	1	1	1	8806993P1	Retaining collar for clamping ring, fan end
57	2	2	2	2	4701899	Cap for commutator
58	1	1	1	1	4701867	Clamping nut for commutator
59	1	1	1	1	4759799	Set of copper and mica exciter commutator segments, finished and bound
	2	2	2	2	4701896	Combination inner and outer mica cone, for front or back of commutator
60	1	1	1	1	4701898	Insulation washer between commutator and windings
	1	1	1	1	4759280	Set of rewinding insulations and wedges, for exciter armature
61	21	21	21	21	3922272P76	Wedge for slot
	1	1	1	1	4701849	Centering collar for exciter armature
62	1	1	1	1	4701852	Retaining nut for exciter armature
	1	1	1	1	6704451	Lock washer for retaining nut
63	1	1	1	1	8806992P1	Spacing collar back of ball bearing, auxiliary generator end
64	1	1	1	1	4748341G1	Ventilating fan
	Δ	Δ	Δ	Δ	6705237P1	Balancing weight for fan (0.032 in. thick)
	Δ	Δ	Δ	Δ	6705237P2	Balancing weight for fan (0.062 in. thick)
	Δ	Δ	Δ	Δ	6705237P3	Balancing weight for fan (0.125 in. thick)
	Δ	Δ	Δ	Δ	20X98	Rivet for balancing weight
65	1	1	1	1	6704901AA	Key for shaft extension
66	1	1	1	1	4701852	Nut for shaft extension
67	1	1	1	1	6704451	Lock washer for nut

Δ Quantity variable.

CABLE

No. of feet Req'd. for Model 5GMG140				Description
A1	A2	B1	C1	
12	12	12	14	19 No. 25 B. & S. wire per SI-12250 (small)
13	15	13	19	61 No. 24 B. & S. wire per SI-12250 (large)

TYPE GMG-140 EXCITER-AUXILIARY GENERATOR

INDEX OF CATALOG NUMBERS

Catalog identifications in this index are arranged in order, reading from *left to right*, first alphabetically according to the prefix letter or letters, if used, and second numerically.

In this index all numbers with a letter prefix will precede those without prefixes.

The number of letters or digits does not affect placement in the table, thus A1999999 will precede A2, and ZZ9999999 will precede Cat. No. 1 (number without a prefix). Letters take precedence over numbers so that Cat. No. 26F1 will precede Cat. No. 261.

Cat. No.	Page	Cat. No.	Page	Cat. No.	Page	Cat. No.	Page
1X452	3	4701849	5	4759798	4	6744330G2	2
12X540	3, 4	4701852	5	4759799	5	6744516G1	2
128968	2	4701867	4, 5	4763978	4	6744516G2	2
133717	3	4701871	4, 5	54X547	2, 3	6751189G1	3
141257	3	4701896	4, 5	54X553	2, 3, 4	6751189G2	3
141259	3	4701898	4, 5	6X825	2, 3, 4	6751189G3	3
143497	4	4701899	4, 5	62342	4	6751189G4	3
143974	3	4720968P1	4, 5	6704451	5	6751194G1	4
144972	2	4720968P2	4, 5	6704604	2	6751194G4	5
158092	2	4729140P4	2	6704901AA	5	6751194G6	4
180937	2	4729140P6	2	6705211	3	6751194G7	4
188187	2	4729539G1	2	6705212	3	8804174P1	2
20X527	3	4729541G1	2	6705219	2	8805111P1	2
20X529	2	4729542G1	3	6705237P1	5	8805152P1	2
20X536	3	4729543G1	2	6705237P2	5	8805176P1	2
20X553	4	4729543G2	2	6705237P3	5	8805105G1	4
20X98	5	4729545G1	3	6705352	2	8806965P1	2
210187	4	4729549G1	4	6705366	2	8806969P1	5
217898	3	4729589G1	4	6705654P1	2	8806970P1	5
227X43	2	4732033P3	4	6722012P1	4	8806980P1	2
248642	2	4732845P2	2	6722019	4	8806984P1	4
257581	4	4748328G1	2	6726073P1	2	8806987P1	2
265042	2	4748341G1	5	6726074P1	2	8806989P1	2
267X30	3	4748354G2	3	6726075P1	2	8806991P1	4
278X11	3	4748354G3	3	6726078P1	4	8806992P1	5
294121	2	4748354G5	3	6726084P1	2	8806993P1	5
3797741	4	4748354G6	3	6726090P1	3	8811883	4
3922272P76	5	4748498G1	2	6726092P1	3	8864950P53	2
421151	3	4759278	5	6726214G1	4	8864950P81	2
422291	3	4759279	5	6732864G1	3	920X88	4
4701839	2	4759280	5	6744330G1	2	920X89	5

WHEN YOU NEED SERVICE

IF YOU NEED TO REPAIR, recondition, or rebuild any electric apparatus, a G-E service shop near you is available day and night, seven days a week, for work in the shops or on your premises. Latest factory methods and genuine G-E renewal parts are used to maintain the original performance of your G-E equipment. For full information about these services, contact the nearest service shop or sales office listed below:

APPARATUS SERVICE SHOPS

Atlanta—Chamblee, Ga. 4639 Peachtree Indus. Blvd.
 Baltimore 30, Md. 920 E. Fort Ave.
 Boston—Medford 55, Mass. Mystic Valley Pkwy.
 Buffalo 11, N. Y. 318 Urban St.
 Charleston 28, W. Va. 306 MacCorkle Ave., S.E.
 Charlotte, N. C. 2328 Thrift Road
 Chicago 80, Ill. 849 S. Clinton St.
 Cincinnati 2, Ohio 444 W. Third St.
 Cleveland 4, Ohio 4966 Woodland Ave.
 Columbus 15, Ohio 213 Cozzens St.
 Dallas 9, Texas 3202 Manor Way
 Denver 5, Colo. 3353 Larimer St.
 Detroit 2, Mich. 5950 Third Ave.
 Houston 20, Texas 5534 Harvey Wilson Drive
 Johnstown, Pa. 841 Oak St.
 Kansas City 8, Mo. 819 E. 19th St.
 Los Angeles 1, Calif. 6900 Stanford Ave.
 Milwaukee 3, Wisc. 940 W. St. Paul Ave.
 Minneapolis 12, Minn. 2025 49th Ave., N.
 New York 14, N. Y. 416 W. 13th St.
 Philadelphia 23, Pa. 429 N. Seventh St.
 Pittsburgh 6, Pa. 6519 Penn Ave.
 Portland 18, Oregon 2727 N.W. 29th Ave.
 Richmond 24, Va. 1403 Ingram Ave.
 St. Louis 10, Mo. 1115 East Road
 San Francisco 3, Calif. 1098 Harrison St.



For service outside the United States, Canada, and Hawaii, consult the nearest office of the International General Electric Company.

Salt Lake City 4, Utah 301 S. Seventh West St.
 Seattle 4, Wash. 3422 First Ave., S.
 Spokane 3, Wash. S. 155 Sherman St.

Toledo 4, Ohio 1 So. St. Clair St.
 York, Pa. 54 N. Harrison St.
 Youngstown 5, Ohio 272 E. Indianola Ave.

APPARATUS SALES OFFICES

Abilene, Texas 442 Cedar St.
 Akron 8, Ohio 335 S. Main St.
 Albany 7, N. Y. 90 State St.
 Albuquerque, N. Mex. 323 Third St., S.W.
 Alexandria, La. 720 Murray St.
 Allentown, Pa. 1014 Hamilton St.
 Amarillo, Texas 719 Amarillo Bldg.
 Appleton, Wisc. 531 W. College Ave.
 Atlanta 3, Ga. Peachtree Rd. at 28th St., N.W.
 Augusta, Ga. 423 Masonic Bldg.
 Augusta, Me. 15 Grove St.
 Bakersfield, Calif. 211 E. 18th St.
 Baltimore 1, Md. 111 Park Ave.
 Bangor, Maine 77 Central St.
 Battle Creek, Mich. 25 W. Michigan Ave.
 Beaumont, Texas 1385 Calder Ave.
 Binghamton, N. Y. 19 Chenango St.
 Birmingham 3, Ala. 1804 Seventh Ave., N.
 Bismarck, N. Dak. 117½ Fifth St.
 Bluefield, W. Va. P.O. Box 447, Appalachian Bldg.
 Boston 1, Mass. 140 Federal St.
 Buffalo 3, N. Y. 535 Washington St.
 Butte, Mont. P.O. Box 836, 103 N. Wyoming St.
 Canton 2, Ohio 700 Tuscarawas St., W.
 Cedar Rapids, Iowa 210 Second St., S.E.
 Charleston 28, W. Va. 306 MacCorkle Ave., S.E.
 Charlotte 1, N. C. 112 S. Tryon St.
 Charlottesville, Va. 123 E. Main St.
 Chattanooga 2, Tenn. 832 Georgia Ave.
 Chicago 80, Ill. P.O. Box 5970A, 840 S. Canal St.
 Cincinnati 2, Ohio 215 W. Third St.
 Cleveland 4, Ohio 4966 Woodland Ave.
 Columbia 1, S.C. P.O. Box 1434, 1420 Lady St.
 Columbus 15, Ohio 40 S. Third St.
 Corpus Christi, Texas 205 N. Chaparral
 Dallas 2, Texas 1801 N. Lamar St.
 Davenport, Iowa 511 Pershing Ave.
 Dayton 2, Ohio 118 W. First St.
 Denver 2, Colo. 650 Seventeenth St.
 Des Moines 9, Iowa 505 W. Fifth Ave.
 Detroit 2, Mich. 700 Antoinette St.
 Duluth 2, Minn. 14 W. Superior St.
 Elmira, N. Y. Main and Woodlawn Aves.
 El Paso, Texas 109 N. Oregon St.
 Erie, Pa. 1001 State St.
 Eugene, Ore. 29 W. Eleventh St.
 Evansville 19, Ind. 123 N.W. Fourth St.
 Fairmont, W. Va. 310 Jacobs Bldg., P.O. Box 1626
 Fergus Falls, Minn. 108 N. Court Ave., P.O. Box 197
 Flint 3, Mich. 653 S. Saginaw St.

Fort Wayne 2, Ind. 127 W. Berry St.
 Fort Worth 2, Texas 408 W. Seventh St.
 Fresno 1, Calif. 407 Patterson Bldg., Tulare and Fulton St.
 Grand Rapids 2, Mich. 148 Monroe Ave., N.W.
 Greensboro, N. C. 301 S. Elm St.
 Greenville, S. C. 108 W. Washington St.
 Hagerstown, Md. Professional Arts Bldg.
 Harrisburg, Pa. 300 N. Second St.
 Hartford 3, Conn. 410 Asylum St.
 Houston 1, Texas 1312 Live Oak St.
 Huntsville, Ala. 1107 Times Bldg.
 Indianapolis 4, Ind. 110 N. Illinois St.
 Jackson, Mich. 120 W. Michigan Ave.
 Jackson 1, Miss. 203 W. Capitol St.
 Jacksonville 2, Fla. 700 E. Union St.
 Jamestown, N. Y. P.O. Box 548, 2 Second St.
 Johnson City, Tenn. 321-323 W. Walnut St.
 Johnstown, Pa. 841 Oak St.
 Joplin, Mo. P.O. Box 931, 220½ W. Fourth St.
 Kansas City 6, Mo. 106 W. Fourteenth St.
 Knoxville 08, Tenn. 602 S. Gay St.
 Lansing 8, Mich. 106 W. Allegan St.
 Lexington, Ky. First National Bank Bldg.
 Lincoln 8, Nebr. 1001 "O" St.
 Little Rock, Ark. 103 W. Capitol Ave.
 Los Angeles 54, Calif. 212 N. Vignes St.
 Louisville 2, Ky. 455 S. Fourth St.
 Macon, Ga. 682 Cherry St.
 Madison 3, Wisc. 16 N. Carroll St.
 Manchester, N. H. 875 Elm St.
 Medford, Ore., P.O. Box 1349, 205 W. Main St.
 Memphis 3, Tenn. 8 N. Third St.
 Miami 32, Fla. 25 S.E. Second Ave.
 Milwaukee 3, Wisc. 940 W. St. Paul Ave.
 Minneapolis 3, Minn. 12 S. Sixth St.
 Mobile 13, Ala. 54 St. Joseph St.
 Montgomery 4, Ala. 205 Montgomery St.
 Nashville 3, Tenn. 234 Third Ave., N.
 Newark 2, N. J. 744 Broad St.
 New Haven 6, Conn. 129 Church St.
 New Orleans 12, La. 837 Gravier St.
 New York 22, N. Y. 570 Lexington Ave.
 Niagara Falls, N. Y. 253 Second St.
 Norfolk 10, Va. 229 W. Bute St.
 Oakland 12, Calif. 409 Thirteenth St.
 Oklahoma City 2, Okla. 119 N. Robinson St.
 Omaha 2, Nebr. 409 S. Seventeenth St.
 Paducah, Ky. P.O. Box 1001, 231 S. Fourth St.
 Pasco, Wash. 421 W. Clark St.
 Peoria 2, Ill. 309 Jefferson Bldg.

Philadelphia 2, Pa. 1405 Locust St.
 Phoenix, Ariz. P.O. Box 4037, 303 Luhrs Tower
 Pittsburgh 22, Pa. 535 Smithfield St.
 Portland 3, Maine 477 Congress St.
 Portland 7, Ore. 920 S.W. Sixth Ave.
 Portsmouth, Ohio P.O. Box 37, 721 Sixth St.
 Providence 3, R. I. Industrial Trust Bldg.
 Raleigh, N. C. 336 Fayetteville St.
 Reading, Pa. 31 N. Sixth St.
 Richmond 17, Va. 700 E. Franklin St.
 Riverside, Calif. 3808 Main St.
 Roanoke 16, Va. 920-924 S. Jefferson St.
 Rochester 4, N. Y. 89 E. Ave.
 Rockford, Ill. 110 S. First St.
 Rutland, Vt. 38½ Center St.
 Sacramento 14, Calif. 626 Forum Bldg.
 Saginaw, Mich. 501 Bearinger Bldg.
 St. Louis 2, Mo. 112 N. Fourth St.
 Salt Lake City 9, Utah 200 S. Main St.
 San Antonio 5, Texas 310 S. St. Mary's St.
 San Diego 1, Calif. 1240 Seventh Ave.
 San Francisco 6, Calif. 235 Montgomery St.
 San Jose 10, Calif. 460 Park Ave.
 Savannah, Ga. 4 E. Bryan St.
 Seattle 4, Wash. 710 Second Ave.
 Shreveport, La. 910 Shelby Bldg.
 Sioux City 13, Iowa 572 Orpheum Electric Bldg.
 Sioux Falls, S. D. 306 South Phillips Ave.
 South Bend 1, Ind. 112 W. Jefferson Blvd.
 Spokane 8, Wash. S. 162 Post St.
 Springfield, Ill. 607 E. Adams St.
 Springfield 3, Mass. 1387 Main St.
 Stockton, Calif. 11 So. San Joaquin St.
 Syracuse 2, N. Y. 113 S. Salina St.
 Tacoma 1, Wash. 1202 Washington Bldg.
 Tampa 6, Fla. 1206 North A St.
 Toledo 4, Ohio 420 Madison Ave.
 Trenton 8, N. J. 214 E. Hanover St.
 Tulsa 3, Okla. 320 S. Boston Ave.
 Tucson, Ariz. P.O. Box 710, 650 N. Sixth Ave.
 Utica 2, N. Y. 258 Genesee St.
 Washington 5, D.C. 777-14th St., N.W.
 Waterbury 89, Conn. 111 W. Main St.
 Waterloo, Iowa 206 W. 4th St.
 Wenatchee, Wash. 328 N. Wenatchee Ave.
 Wheeling, W. Va. 40 Fourteenth St.
 Wichita 2, Kan. 200 E. First St.
 Williamston, N. C. 115 E. Main St.
 Wilmington 98, Del. 1326 N. Market St.
 Worcester 8, Mass. 507 Main St.
 York, Pa. 56 N. Harrison St.
 Youngstown 5, Ohio 272 E. Indianola Ave.

Hawaii: American Factors, Ltd., P. O. Box 3230, Honolulu 1 Canada: Canadian General Electric Company, Ltd., Toronto 17

LOCOMOTIVE AND CAR EQUIPMENT DEPARTMENT, GENERAL ELECTRIC COMPANY, ERIE, PA.

RENEWAL PARTS



TYPE GT-555 GENERATOR

Model Numbers

5GT555A1

5GT555C1

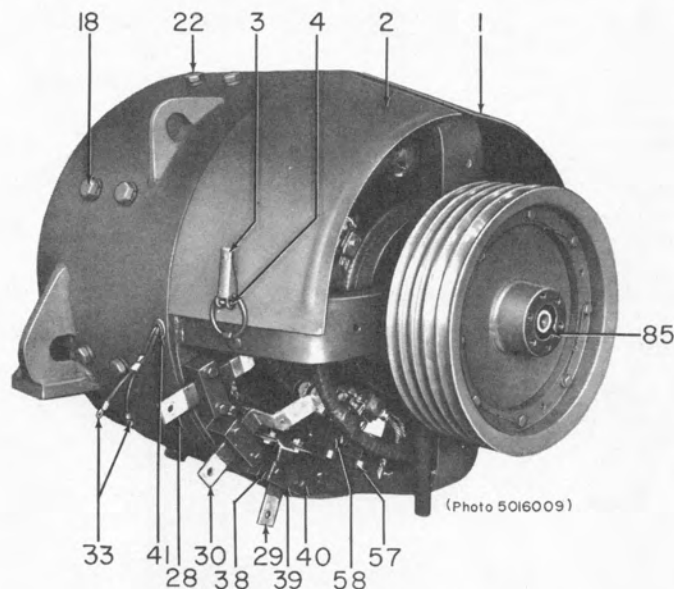

Model 5GT555C1 commutator end

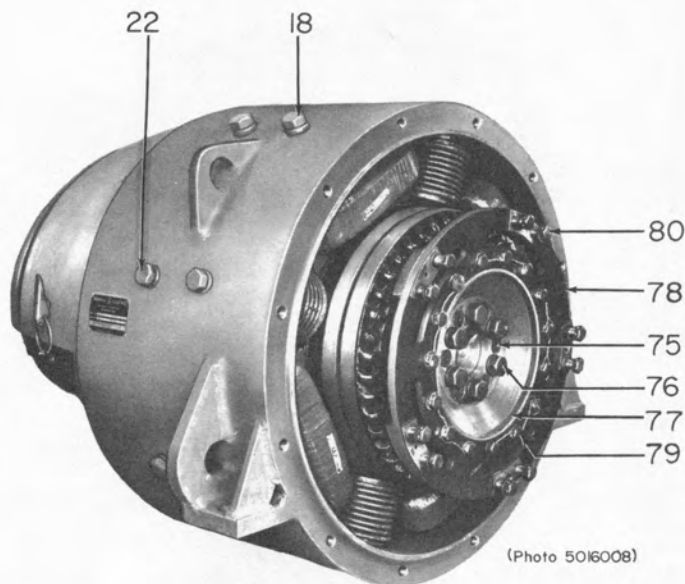

Model 5GT555C1 fan end

When ordering renewal parts, give quantity, catalog number, description of each item required, and complete nameplate reading.

GENERAL  ELECTRIC

TYPE GT-555 GENERATOR

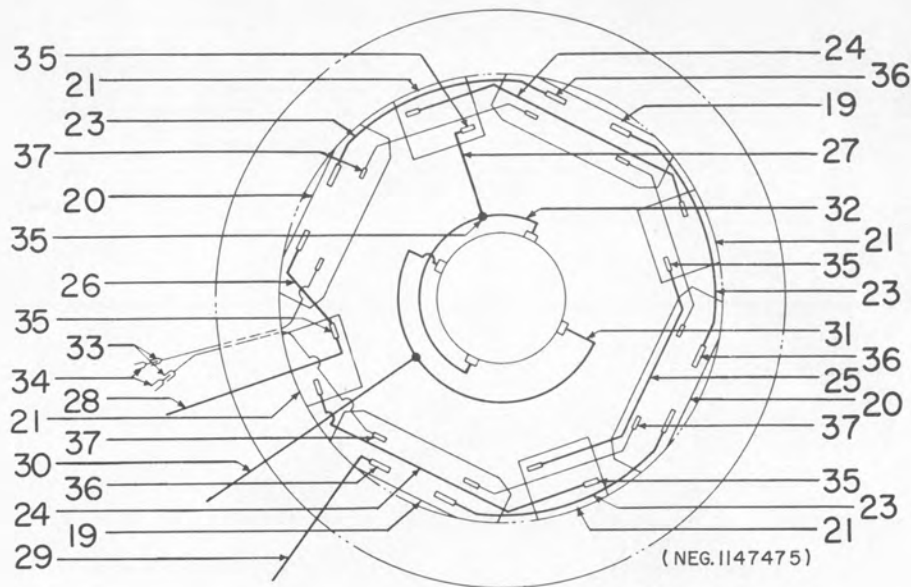

Location of field coils and connections, commutator end

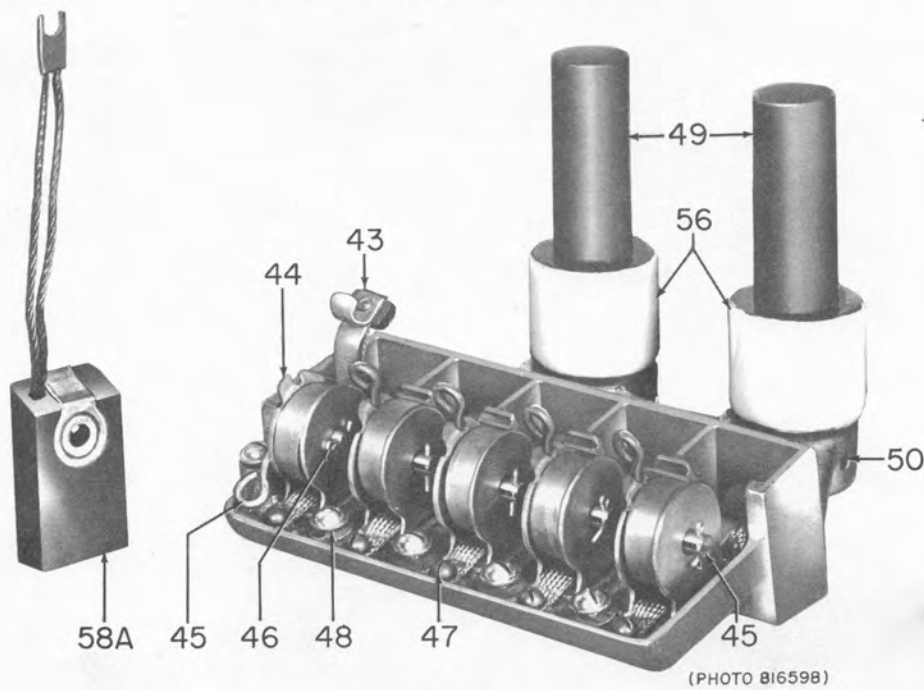

Brush holder ref. no. 42

Ref. No.	No. Req'd. for Model 5GT555-		Cat. No.	Description
	A1	C1		
1	1	1	4748689G2	Commutator inspection cover with clamping lever, right-hand facing commutator end
2	1	1	4748689G1	Commutator inspection cover with clamping lever, left-hand facing commutator end
3	2	2	4759485	Clamping lever with ring link
4	2	2	N312P1816	Hinge rivet for clamping lever, 3/16 in. dia by 1 in., butt. hd., steel
5	1		4744387P3	Bearing cap for roller bearing, inner
6		1	4744387P6	Bearing cap for roller bearing, inner

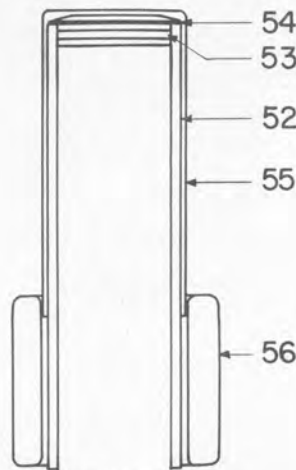

(PHOTO C-1196-I)

Insulation with insulator ref. no. 51

Ref. No.	No. Req'd. for Model 5GT555-		Cat. No.	Description
	A1	C1		
7	1		4744387P4	Bearing cap for roller bearing, outer
8		1	4744387P7	Bearing cap for roller bearing, outer
9		2	8819506P1	Gasket between inner or outer bearing cap and magnet frame
	4	4	N22P29060B	Bolt fastening bearing caps to magnet frame, 1/2 in. -13, 3 3/4 in., hex. hd.
	4	4	N405P45	Lock washer, 1/2 in.
10	1	1	8864954P19	Roller bearing
11	2	2	4713551	Lubricant flinger front or back of roller bearing
12	1	1	2735680G1	Retaining nut with set screws, for roller bearing
13	2	2	N70P2508	Set screw, for retaining nut, 3/8 in. -16, 1/2 in., hex. soc., cup point
14	1	1	2739316G2	Lubricant pipe with fittings and clamp
15	1	1	87X734	Lubricant fitting (Alemite Div., Stewart-Warner Corp., No. 1612)
16	1	1	6704585	Clamp for lubricant pipe
17	1	1	N22P25010B	Screw fastening pipe clamp to magnet frame, 3/8 in. -16, 5/8 in., hex. hd.
	1	1	N405P43	Lock washer, 3/8 in.
	4	4	2735658G1	Laminated pole piece for exciting field coil
18	8	8	8811667	Bolt fastening laminated pole piece to magnet frame
	8	8	N405P50	Lock washer, 1 in.
19	2	2	6751196G2	Exciting field coil, upper right-hand or lower left-hand, facing commutator end
20	2	2	6751196G1	Exciting field coil, upper left-hand or lower right-hand, facing commutator end
21	4	4	4748322G1	Commutating field coil with pole piece
	8	8	4732339P4	Shim for commutating pole piece
22	8	8	8811666	Bolt fastening commutating pole piece to magnet frame
	8	8	N405P49	Lock washer, 7/8 in.
23	3	3	4716052G11	Insulated connection strap for exciting field coil
24	2	2	4716052G3	Insulated connection strap for commutating field coil
25	1	1	4716052G4	Insulated connection strap for commutating field coil
26	1	1	6726203G1	Insulated connection strap, commutating field coil to exciting field coil
27	1	1	4716052G2	Connection strap, commutating field coil to negative bus ring (inner)
28	1	1	4716052G9	Insulated lead strap for commutating field coil
29	1	1	4729553G2	Insulated lead strap for exciting field coil
30	1	1	4729553G1	Insulated lead strap for positive bus ring (outer)
31	1	1	4729544G2	Insulated positive bus ring (outer)
32	1	1	4729544G1	Insulated negative bus ring (inner)
	8	8	262X49	†Solderless terminal for exciting coil connection cable or lead cable, drilled for No. 10 screw (Thomas and Betts Co., No. D26)

† Bulk cable is listed at end of text.

TYPE GT-555 GENERATOR

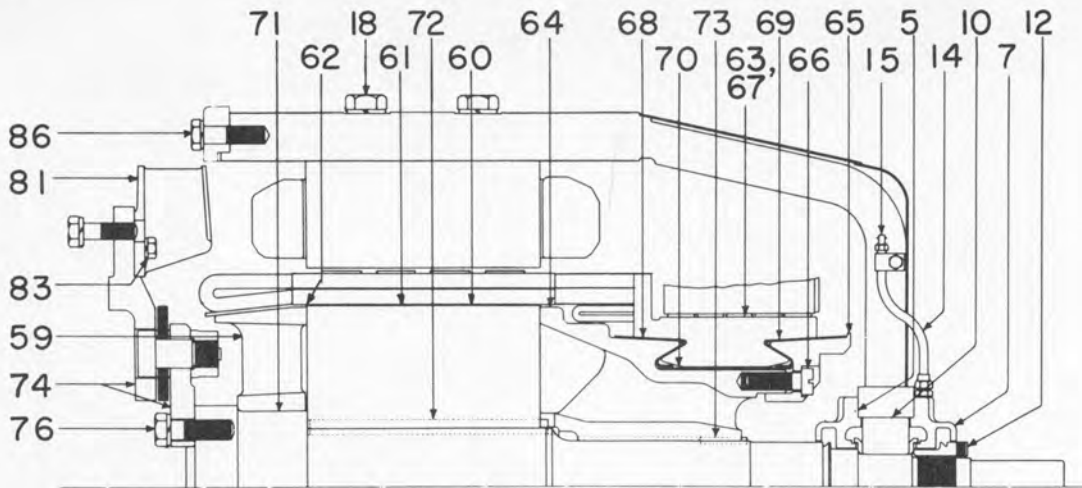

**Longitudinal section of generator
model 5GT555A1**

(NEG. II47476)

Ref. No.	No. Req'd. for Model 5GT555-		Cat. No.	Description
	A1	C1		
33	2	2	266X84	†Solderless terminal for lead cable, drilled for 1/4 in. bolt (Thomas and Betts Co., No. D71)
34	2	2	271X17	Solderless terminal for outside lead, drilled for No. 10 screw (Thomas and Betts Co., No. F26)
35	10	10	64X64	Bolt fastening insulated connection strap or lead to commutating field coil or bus ring, 1/2 in. -13, 1 in., hex. hd., 1/4 in. thick
36	8	8	63X858	Bolt fastening insulated connection strap or lead to exciting field coil, 1/2 in. -13, 3/4 in., hex. hd., 1/4 in. thick
37	4	4	N22P25012B	Bolt fastening bus ring to brush holder, 3/8 in. -16, 3/4 in., hex. hd.
	8	8	N44P16006B	Screw fastening connection cable or lead to field coil, 10-32, 3/8 in., fil. hd.
	18	18	N213P29B	Nut, 1/2 in. -13, hex., jam
	8	8	N210P16B	Nut, 10-32, hex.
	36	36	2703900	Plain washer for 1/2 in. bolt
	4	4	2705410	Plain washer for 3/8 in. bolt
	8	8	N405P39	Lock washer, No. 10
	4	4	6705248	Supporting block for bus rings
	4	4	6705249	Clamping plate for bus rings
	4	4	N22P29032B	Bolt fastening supporting block and clamping plate to magnet frame, 1/2 in. -13, 2 in., hex. hd.
	4	4	N405P45	Lock washer, 1/2 in.
38	6	6	4740774P7	Clamp (half) for insulated lead strap
39	3	3	4707296	Plate washer
40	6	6	N22P29044B	Bolt fastening lead strap clamp to magnet frame, 1/2 in. -13, 2 3/4 in., hex. hd.
	6	6	N405P45	Lock washer, 1/2 in.
41	1	1	8819217	Soft rubber bushing for cable leads
42	4	4	4729519G1	Brush holder with pressure arms and insulated studs
43	20	20	2380115	Pressure arm with shunt and tip
44	20	20	1320553	Holder for pressure arm
45	20	20	4754266	Hinge pin with adjusting lever, for pressure arm
46	20	20	N503P606B	Cotter pin for hinge pin, 1/16 in. dia by 3/8 in.
47	20	20	N37P14006B	Screw fastening pressure arm shunt to brush holder, 8-36, 3/8 in., rd. hd.
	20	20	N405P38	Lock washer, No. 8
48	20	20	4705754	Binding screw for brush pigtail
49	8	8	4732329G2	Insulated stud
50	8	8	87X546	Pin for insulated stud and brush holder body, 1/8 in. dia by 1 5/8 in.
51	8	8	4732329G3	Insulation with porcelain insulator
52	8	8	186V300	Insulation sleeve

† Bulk cable is listed at end of text.

TYPE GT-555 GENERATOR

GEF-2949B

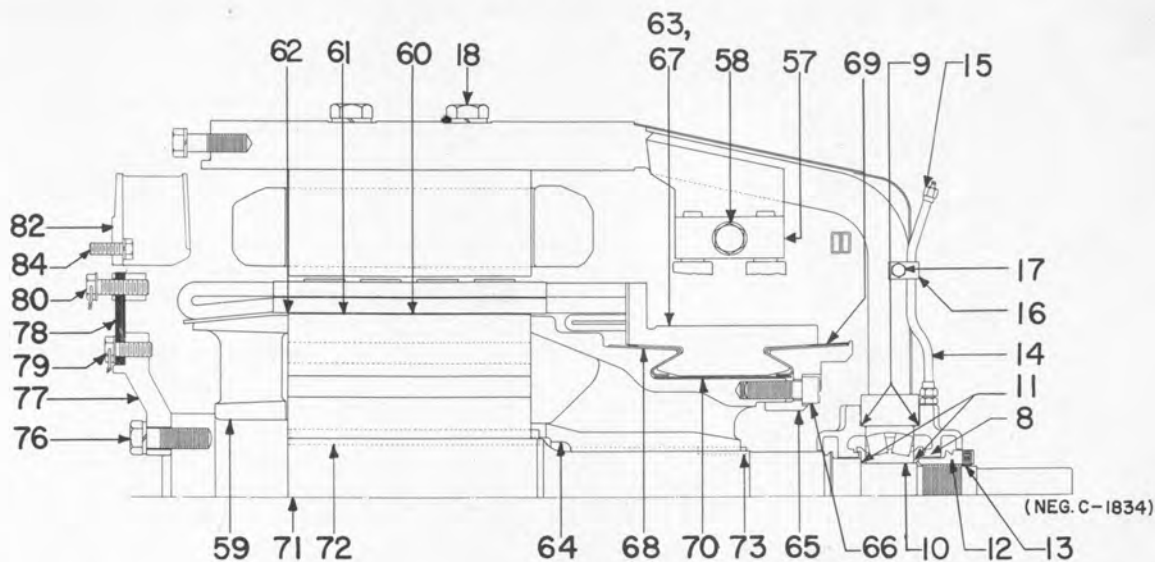

Longitudinal section model 5GT555C1

Ref. No.	No. Req'd, for Model 5GT555-		Cat. No.	Description
	A1	C1		
53	32	32	2717148	Insulation washer for stud (small)
54	24	24	1428223	Insulation washer for stud (large)
55	8	8	186V469	Clamping sleeve for stud
56	8	8	2467286	Porcelain insulator for stud NOTE: Glass tape used between insulation sleeve and insulator is 0.015 in. by 1 in. G-E Material A2L7B. Tape must be treated by customer before applying. (Advice for treating will be furnished on request.)
57	4	4	4729531G1	Brush holder support (two parts)
58	4	4	N22P35048	Bolt fastening brush holder support to magnet frame, 3/4 in. -10, 3 in., hex. hd.
58A	4	4	N405P48	Lock washer, 3/4 in.
	20	20	6726218	πCarbon brush with pigtail
	1	1	4748320G1	Armature with commutator and shaft
	1	1	4748330G5	Armature rewinding kit consisting of: armature coils, equalizer coils, filler pieces, and set of armature rewinding insulations
	1	1	4748330G4	Set of armature binding insulations NOTE: Binder over commutator mica is A4A3B6 Cord. Sealer over commutator mica is A50E19A Varnish. Glass Tape is 0.005 in. by 3/4 in. A2L7B. (Tape must be treated by customer before applying. Advice for treating will be furnished on request.) Binding wire for core bands is 0.057 in. dia. B7A3, requiring approximately 335 ft (3 lbs). Binding wire for end bands is 0.057 in. dia. B4Y2, requiring approximately 320 ft (2.8 lbs). All are G-E Materials.
59	1	1	2735661P1	Armature head
	1	1	946X84	Set of armature punchings
60	269	269	2735673G1	Main punching (0.025 in. thick)
61	116	116	2735673G2	Groove punching (0.025 in. thick)
62	6	6	2735673G3	End punching (0.064 in. thick)
63	1	1	4729494G2	Commutator (seasoned)
63	1	1	4729494G1	§Commutator (unseasoned)

π When ordering, be sure to give complete nameplate designation of device for which Carbon Brush is to be used.

§ Customers not having commutator seasoning equipment should not order an unseasoned commutator nor a set of commutator segments. If customer has commutator seasoning equipment, advice for seasoning will be furnished on request.

TYPE GT-555 GENERATOR

Ref. No.	No. Req'd. for Model 5GT555-		Cat. No.	Description
	A1	C1		
64	1	1	4729493P1	Shell for commutator
65	1	1	2744617P12	Cap for commutator
66	12	12	N29P35040	Bolt clamping commutator cap to shell, 3/4 in. -10, 2 1/2 in., hex. soc. hd.
67	1	1	4729494P4	§Set of copper and mica commutator segments, finished and bound (must be seasoned after assembly)
68	1	1	6709971P1	Combination inner and outer mica cone for back of commutator
69	1	1	6709972P1	Combination inner and outer mica cone for front of commutator
70	1	1	4729494P7	Mica collar under segments
71	1	1	2735675G2	Armature shaft with keys
72	1	1	4713531	Key for shaft and punchings
73	1	1	4713532	Key for shaft and commutator
	1	1	2766829ADP26	‡Balancing weight for armature head
	1	1	2766829ADP17	‡Balancing weight for commutator
74	1		4748329G1	Flexible coupling
75	6		4713629	Dowel pin for armature shaft and flexible coupling
76	6		N22P37044	Bolt fastening flexible coupling to armature shaft, 7/8 in. -9, 2 3/4 in., hex. hd.
	6		N405P49	Lock washer, 7/8 in.
77		1	9949931G1	Coupling flange with flexible disk
78		1	9949930P5	Flexible disk for coupling flange
75		6	4713629	Dowel pin for armature shaft and coupling flange
76		6	N22P37044	Bolt fastening coupling flange to armature shaft, 7/8 in. -9, 2 3/4 in. hex. hd.
		6	N405P49	Lock washer, 7/8 in.
79		15	8805142P1	Bolt fastening disk to coupling flange
80		10	8811635	Bolt fastening engine flywheel to flexible disk
		25	8805847P1	Plain washer
81	1		4744386G7	Fan
82		1	4744386G8	Fan
83	6		N22P29020B	Bolt fastening fan to flexible coupling, 1/2 in. -13, 1 1/4 in., hex. hd.
84		6	N22P29024B	Bolt fastening fan to engine flywheel, 1/2 in. -13, 1 1/2 in., hex. hd.
	6	6	N405P45	Lock washer, 1/2 in.
85	1	1	4713539	Key for shaft and pulley
86	12		4707552	Bolt fastening engine flywheel housing to generator magnet frame
	12		N405P48	Lock washer, 3/4 in.

CABLE

Cable used for exciting field coil connections and leads is 37 No. 24 wire, M-9947305AB, requiring approximately 6 feet.

§ Customers not having commutator seasoning equipment should not order an unseasoned commutator nor a set of commutator segments. If customer has commutator seasoning equipment, advice for seasoning will be furnished on request.

‡ Balancing weights are furnished in complete rings, to be cut to suit when balancing armature. Each ring contains sufficient stock to balance approximately three armatures.

TYPE GT-555 GENERATOR

GEF-2949B

INDEX OF CATALOG NUMBERS

Catalog identifications in this index are arranged in order, reading from *left to right*, first alphabetically according to the prefix letter or letters, if used, and second numerically.

In this index all numbers with a letter prefix will precede those without prefixes.

The number of letters or digits does not affect placement in the table, thus A1999999 will precede A2, and ZZ9999999 will precede Cat. No. 1 (number without a prefix). Letters take precedence over numbers so that Cat. No. 26F1 will precede Cat. No. 261.

Cat. No.	Page	Cat. No.	Page	Cat. No.	Page	Cat. No.	Page
N210P16B-----	4	2467286-----	5	4716052G4 ----	3	4748689G1 ----	2
N213P29B-----	4	262X49 -----	3	4716052G9 ----	3	4748689G2 ----	2
N22P25010B---	3	266X84 -----	4	4729493P1 ----	6	4754266-----	4
N22P25012B---	4	2703900-----	4	4729494G1 ----	5	4759485-----	2
N22P29020B---	6	2705410-----	4	4729494G2 ----	5	63X858 -----	4
N22P29024B---	6	271X17 -----	4	4729494P4 ----	6	64X64 -----	4
N22P29032B---	4	2717148-----	5	4729494P7 ----	6	6704585-----	3
N22P29044B---	4	2735658G1 ----	3	4729519G1 ----	4	6705248-----	4
N22P29060B---	3	2735661P1 ----	5	4729531G1 ----	5	6705249-----	4
N22P35048 ----	5	2735673G1 ----	5	4729544G1 ----	3	6709971P1 ----	6
N22P37044 ----	6	2735673G2 ----	5	4729544G2 ----	3	6709972P1 ----	6
N29P35040 ----	6	2735673G3 ----	5	4729553G1 ----	3	6726203G1 ----	3
N312P1816 ----	2	2735675G2 ----	6	4729553G2 ----	3	6726218-----	5
N37P14006B---	4	2735680G1 ----	3	4732329G2 ----	4	6751196G1 ----	3
N405P38 -----	4	2739316G2 ----	3	4732329G3 ----	4	6751196G2 ----	3
N405P39 -----	4	2744617P12 ---	6	4732339P4 ----	3	87X546 -----	4
N405P43 -----	3	2766829ADP17-6		4740774P7 ----	4	87X734 -----	3
N405P45 -----	3,4,6	2766829ADP26-6		4744386C7 ----	6	8805142P1 ----	6
N405P48 -----	5,6	4705754-----	4	4744386C8 ----	6	8805847P1 ----	6
N405P49 -----	3,6	4707296-----	4	4744387P3 ----	2	8811635-----	6
N405P50 -----	3	4707552-----	6	4744387P4 ----	3	8811666-----	3
N44P16006B ---	4	4713531-----	6	4744387P6 ----	2	8811667-----	3
N503P606B ---	4	4713532-----	6	4744387P7 ----	3	8819217-----	4
N70P2508 ----	3	4713539-----	6	4748320G1 ----	5	8819506P1 ----	3
1320553-----	4	4713551-----	3	4748322G1 ----	3	8864954P19 ---	3
1428223-----	5	4713629-----	6	4748329G1 ----	6	946X84 -----	5
186V300 -----	4	4716052G11 ---	3	4748330G4 ----	5	9949930P5 ----	6
186V469 -----	5	4716052G2 ----	3	4748330G5 ----	5	9949931G1 ----	6
2380115-----	4	4716052G3 ----	3				

WHEN YOU NEED SERVICE

IF YOU NEED TO REPAIR, recondition, or rebuild any electric apparatus, a G-E service shop near you is available day and night, seven days a week, for work in the shops or on your premises. Latest factory methods and genuine G-E renewal parts are used to maintain the original performance of your G-E equipment. For full information about these services, contact the nearest service shop or sales office listed below:

APPARATUS SERVICE SHOPS

Appleton, Wisc. Midway Industrial Area,
County Trunk, "P"
Atlanta—Chamblee, Ga. 4639 Peachtree
Indus. Blvd.
Baltimore 30, Md. 920 E. Fort Ave.
Boston—Medford 55, Mass. Mystic Valley Pkwy.
Buffalo 11, N. Y. 318 Urban St.
Charleston 28, W. Va. 306 MacCorkle Ave., S.E.
Charlotte, N. C. 2328 Thrift Road
Chicago 32, Ill. 4360 W. 47th St.
Cincinnati 2, Ohio 444 W. Third St.
Cleveland 4, Ohio 4966 Woodland Ave.
Columbus 15, Ohio 213 Cozzens St.
Dallas 9, Texas 3202 Manor Way
Davenport—Bettendorf, Ia. 1039 State St.
Decatur, Ill. 2225 E. Logan St.
Denver 5, Colo. 3353 Larimer St.
Detroit 2, Mich. 5950 Third Ave.
Houston 20, Texas 5534 Harvey Wilson Drive
Indianapolis, Ind. 1740 W. Vermont St.
Johnstown, Pa. 841 Oak St.
Kansas City 8, Mo. 819 E. 19th St.
Los Angeles 1, Calif. 6900 Stanford Ave.
Louisville, Ky. 2014 New Main St.
Midland, Tex. 3404 Bankhead Hwy.
Milwaukee 3, Wisc. 940 W. St. Paul Ave.
Minneapolis 12, Minn. 2025 49th Ave., N.
New York 14, N. Y. 416 W. 13th St.
Philadelphia 23, Pa. 1040 E. Erie Ave.
Pittsburgh 6, Pa. 6519 Penn Ave.
Portland 18, Oregon 2727 N.W. 29th Ave.
Richmond 24, Va. 1403 Ingram Ave.
St. Louis 10, Mo. 1115 East Road
Salt Lake City 4, Utah 301 S. Seventh West St.
San Francisco 3, Calif. 1098 Harrison St.
Seattle 4, Wash. 3422 First Ave., S.
Spokane 3, Wash. S. 115 Sherman St.
Toledo 4, Ohio 1 So. St. Clair St.
York, Pa. 54 N. Harrison St.
Youngstown 5, Ohio 272 E. Indianola Ave.



For service outside the United States, Canada, and Hawaii, consult the nearest office of the International General Electric Company.

APPARATUS SALES OFFICES

Abilene, Texas 442 Cedar St.
Akron 8, Ohio 335 S. Main St.
Albany 7, N. Y. 90 State St.
Albuquerque, N. Mex. 323 Third St., S.W.
Alexandria, La. 720 Murray St.
Allentown, Pa. 1014 Hamilton St.
Amarillo, Texas 402 Amarillo Bldg.
Appleton, Wisc. 531 W. College Ave.
Atlanta 3, Ga. 1860 Peachtree Rd., N.W.
Augusta, Ga. 423 Masonic Bldg.
Augusta, Me. 15 Grove St.
Bakersfield, Calif. 211 E. 18th St.
Baltimore 1, Md. 111 Park Ave.
Bangor, Maine 77 Central St.
Baton Rouge 6, La. 3170 Florida Blvd.
Battle Creek, Mich. 25 W. Michigan Ave.
Beaumont, Texas 1385 Calder Ave.
Billings, Mont. 107 1/2 N. 27th St.
Binghamton, N. Y. 19 Chenango St.
Birmingham 3, Ala. 1804 Seventh Ave., N.
Bismarck, N. Dak. 418 Rosser Ave.
Bluefield, W. Va. P.O. Box 447, Appalachian Bldg.
Boise, Idaho 1524 Idaho St.
Boston 1, Mass. 140 Federal St.
Buffalo 3, N. Y. 535 Washington St.
Butte, Mont. P.O. Box 836, 103 N. Wyoming St.
Canton 2, Ohio 700 Tuscarawas St., W.
Cedar Rapids, Iowa 210 Second St., S.E.
Charleston 28, W. Va. 306 MacCorkle Ave., S.E.
Charlotte 1, N. C. 112 S. Tryon St.
Chattanooga 2, Tenn. 832 Georgia Ave.
Chicago 80, Ill. P.O. Box 5970A, 840 S. Canal St.
Cincinnati 2, Ohio 215 W. Third St.
Cleveland 4, Ohio 4966 Woodland Ave.
Columbia 1, S.C. P.O. Box 1434, 1420 Lady St.
Columbus 15, Ohio 40 S. Third St.
Corpus Christi, Texas 205 N. Chaparral
Dallas 2, Texas 1801 N. Lamar St.
Davenport—Bettendorf, Ia. 1039 State St.
Dayton 2, Ohio 11 W. Monument Bldg.
Denver 2, Colo. 650 Seventeenth St.

Des Moines 9, Iowa 505 W. Fifth Ave.
Detroit 2, Mich. 700 Antoinette St.
Duluth 2, Minn. 14 W. Superior St.
Elmira, N. Y. Main and Woodlawn Aves.
El Paso, Texas 215 No. Stanton
Erie, Pa. 1001 State St.
Eugene, Ore. 610 High St.
Evansville 19, Ind. 123 N.W. Fourth St.
Fairmont, W. Va. 310 Jacobs Bldg.,
P.O. Box 1626
Fergus Falls, Minn. 108 N. Court Ave. P.O. Box 197
Flint 3, Mich. 653 S. Saginaw St.
Fort Wayne 6, Ind. 3606 So. Calhoun
Fort Worth 2, Texas 408 W. Seventh St.
Fresno 1, Calif. 407 Patterson Bldg.
Tulare and Fulton St.
Grand Rapids 2, Mich. 148 Monroe Ave., N.W.
Greensboro, N. C. 301 S. Elm St.
Greenville, S. C. 108 W. Washington St.
Gulfport, Miss. 207 Jo-Fran Bldg.
Hagerstown, Md. Professional Arts Bldg.
Harrisburg, Pa. 300 N. Second St.
Hartford 3, Conn. 410 Asylum St.
Houston 1, Texas 1312 Live Oak St.
Huntsville, Ala. 1107 Times Bldg.
Indianapolis 4, Ind. 110 N. Illinois St.
Jackson, Mich. 120 W. Michigan Ave.
Jackson 1, Miss. 203 W. Capitol St.
Jacksonville 2, Fla. 700 E. Union St.
Jamestown, N. Y. P.O. Box 548, 2 Second St.
Johnson City, Tenn. 321-323 W. Walnut St.
Johnstown, Pa. 841 Oak St.
Joplin, Mo. P.O. Box 948, 220 1/2 W. Fourth St.
Kalamazoo 3, Mich. 112 Parkway Ave.
Kansas City 6, Mo. 106 W. Fourteenth St.
Knoxville 08, Tenn. 602 S. Gay St.
Lansing 8, Mich. 306 Michigan National Tower
Lexington, Ky. First National Bank Bldg.
Lincoln 8, Nebr. Sharpe Bldg., 206 S. 13th St.
Little Rock, Ark. 103 W. Capital Ave.
Los Angeles 54, Calif. 212 N. Vignes St.
Louisville 2, Ky. 455 S. Fourth St.
Macon, Ga. 682 Cherry St.
Madison 3, Wisc. 16 N. Carroll St.
Manchester, N. H. 875 Elm St.
Medford, Ore., P.O. Box 1349, 205 W. Main St.
Memphis 3, Tenn. 8 N. Third St.
Miami 32, Fla. 25 S.E. Second Ave.
Milwaukee 3, Wisc. 940 W. St. Paul Ave.
Minneapolis 3, Minn. 12 S. Sixth St.
Mobile 13, Ala. 54 St. Joseph St.
Montgomery 4, Ala. 205 Montgomery St.
Nashville 3, Tenn. 234 Third Ave., N.
Newark 2, N. J. 744 Broad St.
New Haven 6, Conn. 129 Church St.
New Orleans 12, La. 837 Gravier St.
New York 22, N. Y. 570 Lexington Ave.
Niagara Falls, N. Y. 253 Second St.

Norfolk 10, Va. 229 W. Bute St.
Oakland 12, Calif. 409 Thirteenth St.
Oklahoma City 2, Okla. 119 N. Robinson St.
Omaha 2, Nebr. 409 S. Seventeenth St.
Pasco, Wash. 421 W. Clark St.
Peoria 2, Ill. 309 Jefferson Bldg.
Philadelphia 2, Pa. 1405 Locust St.
Phoenix, Ariz. P.O. Box 4037, 303 Luhrs Tower
Pittsburgh 22, Pa. The Oliver Bldg., Mellon Sq.
Portland 3, Maine 477 Congress St.
Portland 7, Ore. 920 S.W. Sixth Ave.
Providence 3, R. I. Industrial Trust Bldg.
Raleigh, N. C. 336 Fayetteville St.
Reading, Pa. 31 N. Sixth St.
Richmond 17, Va. 700 E. Franklin St.
Riverside, Calif. 3570 Ninth St.
Roanoke 16, Va. 920-924 S. Jefferson St.
Rochester 4, N. Y. 89 E. Ave.
Rockford, Ill. 110 S. First St.
Rutland, Vt. 38 1/2 Center St.
Sacramento 14, Calif. 626 Forum Bldg.
Saginaw, Mich. Second National Bank Bldg.
St. Louis 1, Mo. 818 Olive St.
Salt Lake City 9, Utah 200 S. Main St.
San Antonio 5, Texas 434 So. Main Ave.
San Diego 1, Calif. 1240 Seventh Ave.
San Francisco 6, Calif. 235 Montgomery St.
San Jose 10, Calif. 460 Park Ave.
Savannah, Ga. 4 E. Bryan St.
Seattle 4, Wash. 710 Second Ave.
Shreveport, La. 910 Shelby Bldg.
Sioux City 13, Iowa 572 Orpheum Electric Bldg.
Sioux Falls, S. D. 306 South Phillips Ave.
South Bend 1, Ind. 112 W. Jefferson Blvd.
Spokane 8, Wash. S. 162 Post St.
Springfield, Ill. 607 E. Adams St.
Springfield 3, Mass. 1387 Main St.
Stockton, Calif. 11 So. San Joaquin St.
Syracuse 2, N. Y. 113 S. Salina St.
Tacoma 1, Wash. 1202 Washington Bldg.
Tampa 6, Fla. 1206 North A St.
Toledo 4, Ohio 420 Madison Ave.
Trenton 8, N. J. 214 E. Hanover St.
Tucson, Ariz. P.O. Box 710, 650 N. Sixth Ave.
Tulsa 3, Okla. 320 S. Boston Ave.
Utica 2, N. Y. 258 Genesee St.
Washington 5, D.C. 777-14th St., N.W.
Waterbury 89, Conn. 111 W. Main St.
Waterloo, Iowa 206 W. 4th St.
Wenatchee, Wash. 328 N. Wenatchee Ave.
Wheeling, W. Va. 40 Fourteenth St.
Wichita 2, Kan. 200 E. First St.
Williamston, N. C. 115 E. Main St.
Wilmington 98, Del. 1326 N. Market St.
Worcester 5, Mass. 228 Grove St.
York, Pa. 56 N. Harrison St.
Youngstown 5, Ohio 272 E. Indianola Ave.

Hawaii: American Factors, Ltd., P. O. Box 3230, Honolulu 1 Canada: Canadian General Electric Company, Ltd., Toronto

LOCOMOTIVE AND CAR EQUIPMENT DEPARTMENT, GENERAL ELECTRIC COMPANY, ERIE, PA.

RENEWAL PARTS



TYPE 17LH13 RELAYS

Forms 1B1, 1B2, C1, C2, +D1, D6, and F6

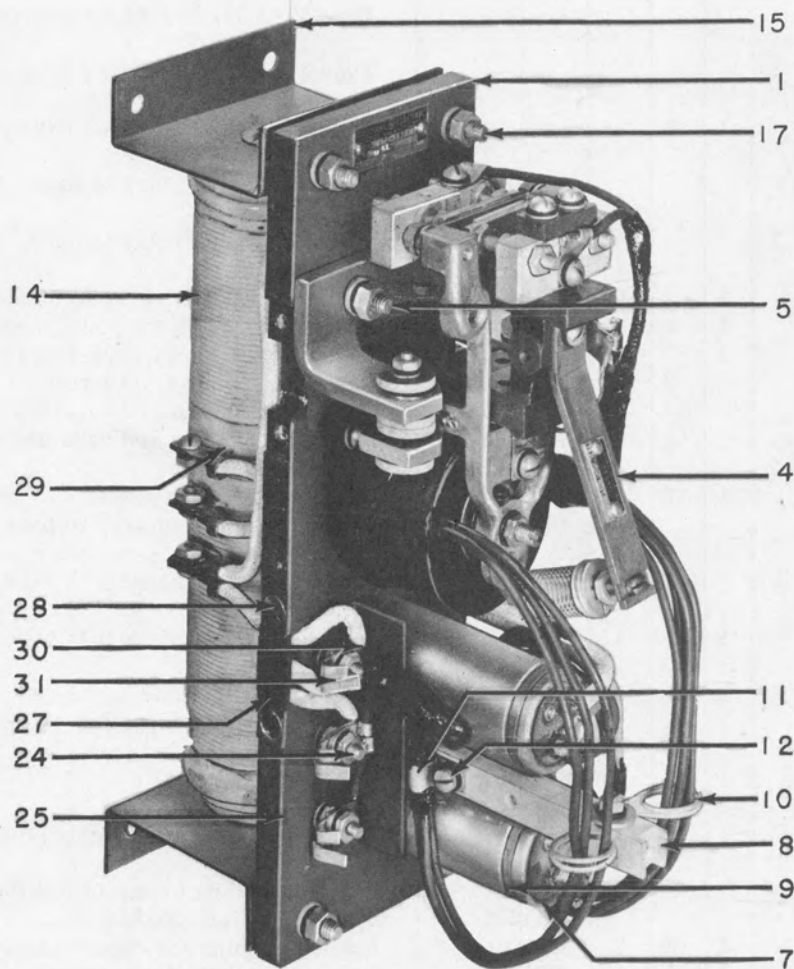

Type 17LH13B relay

When ordering renewal parts, give quantity, catalog number, description of each item required, and complete nameplate reading.

GENERAL ELECTRIC

TYPE 17LH13 RELAYS

Ref. No.	Number Required for Type 17LH13-							Cat. No.	Description
	† B1	† B2	C1	C2	+ D1	D6	F6		
1	1	1						6721599	Base
1			1	1				6721931P1	Base
1					1	1	1	6724247	Base
2					1	1		6724227G1	Frame with studs
2							1	6724227G2	Frame with studs
3					1	1	1	6712168	Insulation shield between base and frame
			1	1				6711640P1	Insulation shield for base
			2	2				225X29	Wood screw fastening insulation shield to base
4	1							-----	Type 17LV23L18 RELAY (For parts see bulletin GEF-2907)
4		1						-----	Type 17LV23L20 RELAY (for parts see bulletin GEF-2907)
4			1	1				-----	Type 17LV23M19 RELAY (For parts see bulletin GEF-2907)
4					1	1	1	-----	Type 17LV23L26 RELAY (For parts see bulletin GEF-2907)
5	2	2						36X702	Screw fastening relay to base, 1/4 in. -20, 1 1/4 in. hex. h.
			2	2				46X820	Screw fastening relay to base, 1/4 in. -20, 3/4 in. hex. h.
					2	2	2	6712176	Insulation sleeve for relay mounting stud
6					4	4	4	6712130	Insulation spacer for relay mounting stud
7	2	2			2			271X62	Capacitor, 10 mu f, 300-volt (# 94680)
7						2	2	8862685G1	Capacitor, 4 mu f, 110-volt
7							5	595X84	Capacitor, 0.1 mu f (# AS145)
8	1	1						6710885	Support for cover and capacitors
8			1	1				6711639P1	Support for cover
8					1	1	1	6712180	Support for capacitors
	1	1						46X794	Screw fastening support to base, 1/4 in. -20, 3/4 in. f. h.
			1	1				46X820	Screw fastening support to base, 1/4 in. -20, 3/4 in. hex. h.
					1	1	1	46X777	Screw fastening support to base, 1/4 in. -20, 1 in. hex. h.
9	2	2			2	2	2	6714158	Clamp for capacitor
	1	1			1	1	1	133767	Screw fastening capacitor clamp to support, 10-32, 1/2 in. fil. h.
10	1	1			1	1	1	6711553	Cable clamp (wire)
11	2	2			2	2	2	6711552P1	Cable clamp (flat strip)
12	2	2			1	1	1	243044	Screw fastening clamp in position, 10-32, 3/8 in. fil. h.
	1	1						20X550	Screw fastening clamp in position, 10-32, 1 in. fil. h.
	1	1						6711525	Spacer for Cat. 20X550
13					2	2	2	225X30	Rubber bushing for cables (Δ 1450)
14	1	1			1	1	1	4759053	Resistor unit (114.85 ohms)
	7	7			7	7	7	143528	Screw fastening terminal to resistor unit, 10-32, 5/16 in. r h
15	2	2			2	2	2	6710886	Resistor unit support
	2	2						6711571P1	Insulation shield for resistor support
16					1	1	1	6725041	Frame for resistor unit supports
					1	1	1	6725042G1	Cover for resistor unit
					6	6	6	133767	Screw fastening cover to frame, 10-32, 1/2 in. fil. h
	1	1			1	1	1	4704658	Tie rod for resistor unit
	† B1	† B2	C1	C2	+ D1	D6	F6		

† The Type 17LH13B1 or -B2 Relays may be changed to the Type 17LH13D6 by ordering a set of changeover parts Cat. 107X61.

+ The Type 17LH13D1 Relay may be changed to the Type 17LH13D6 by ordering a set of changeover parts Cat. No. 106X36.

P. R. Mallory & Co.

Δ Continental Rubber Works.

TYPE 17LH13 RELAYS

GEF-3030C

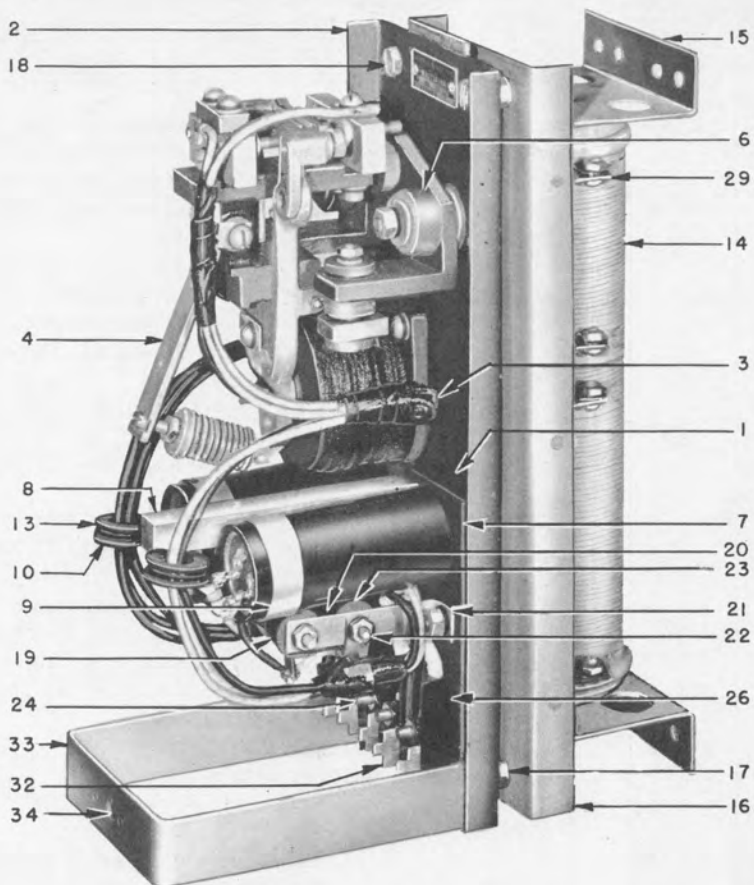

Type 17LH13D relay

Ref. No.	Number Required for Type 17LH13-							Cat. No.	Description
	¶ B1	¶ B2	C1	C2	+ D1	D6	F6		
17, 18	4	4			4	4	4	36X702	Screw fastening Cat. 6710886 to base, 1/4 in. -20, 1 1/4 in. hex. h.
			2					5758472C10L	Resistor unit, 1 ohm
				2				5758472C18L	Resistor unit, 1.75 ohms
			1					196X33	Resistor unit, 7.2 ohms
				1				190X76	Resistor unit, 7.1 ohms
			3	3				225X35	Mounting screw for resistor unit, 1/4 in. -20, 4 3/4 in. hex. h.
			6	6				6706906	Insulation spacer for resistor unit
19					1			225X36	Resistor unit, 10 ohms (ø 0200B)
19						1	1	279X78	Resistor unit, 4 ohms (ø 0200N)
20					1	1	1	225X37	Resistor unit, 400 ohms (ø 0371C)
21					2	2	2	6712178	Support for resistor units
22					2	2	2	4731833P18	Screw fastening resistor unit to supports
23					4	4	4	6712179	Insulation spacer for resistor unit
24	4	5						4731833P12	Connection screw for base
24			4	4				4731833P13	Connection screw for base
24					5	5	5	4731833P10	Connection screw for base
	¶ B1	¶ B2	C1	C2	+ D1	D6	F6		

¶ The Type 17LH13B1 or -B2 Relays may be changed to the Type 17LH13D6 by ordering a set of changeover parts Cat. 107X61.

+ The Type 17LH13D1 Relay may be changed to the Type 17LH13D6 by ordering a set of changeover parts Cat. No. 106X36.

ø Ohmite Mfg. Co.

TYPE 17LH13 RELAYS

Ref. No.	Number Required for Type 17LH13-							Cat. No.	Description
	¶ B1	¶ B2	C1	C2	+ D1	D6	F6		
25	1	1						6711569P1 6711570P1	Insulation shield for three connection screws Insulation shield for one connection screw
26	1	1						6712181	Insulation shield for connection screw
27	2	2						6706904	Clamp for cables
28	4	4						98X125	Screw fastening clamp to base
					1	1		6712182	Marking plate for connection screws
29	7	7	4	4	7	7	7	417591	Tinned copper terminal, straight
30	3	4	2	2				434048	Tinned copper terminal, flag type, right-hand (double loop)
31	1	1	2	2				410567	Tinned copper terminal, flag type, left-hand (double loop)
			4	4				4708130	Tinned copper terminal; 0.195 in. bolt hole (single loop)
32					10	10	10	282X68 4704352	Solderless terminal (/// B36G) Tinned copper terminal, 17/64 in. bolt hole (single loop)
33					1	1		6724248G1	Supporting bracket with catch, for cover
33							1	6724248G3	Supporting bracket with catch, for cover, upper
33							1	482A506G1	Supporting bracket with catch, for cover, lower
34					1	1	2	4757154	Spring catch with rivets, for cover
	1	1	1	1				4728939G1	Cover with screw
					1	1		2738996G1	Cover with fastener
							1	9948647G1	Cover with fasteners
	1	1	1	1				6710888	Screw for cover
	1	1	1	1				6710959	Snap ring for screw
				1	1	2		87X24	Fastener for cover (% A5-40)
				1	1	2		87X32	Grommet for fastener (% GA5-375)
	¶ B1	¶ B2	C1	C2	+ D1	D6	F6		

NOTE: The following items are steel unless otherwise specified.

PLAIN WASHERS

Cat. No.	Description
150279	For No. 10 screw
143974	For 1/4 in. screw, 1/16 in. thick
145978 ⁷	For 1/4 in. screw, 1/8 in. thick
2712754	For 1/4 in. screw, 3/16 in. thick
2432292	For 1/4 in. screw, compound

LOCK WASHERS

Cat. No.	Description
54X441	For No. 10 screw
30X562	For 1/4 in. screw
69X842	For 1/4 in. screw, csk (& 1514)
66X896	For 1/4 in. screw, internal (& 1214)
596X30	For 1/4 in. screw, internal and external (& 4014-20-00)

NUTS

Cat. No.	Description
145996	10-32, hex. std
1X452	1/4 in. -20, hex. std

¶ The Type 17LH13B1 or -B2 Relays may be changed to the Type 17LH13D6 by ordering a set of changeover parts Cat. No. 107X61.

+ The Type 17LH13D1 Relay may be changed to the Type 17LH13D6 by ordering a set of changeover parts Cat. No. 106X36.

% Dzus Fastener Co.
& Shakeproof Lock Washer Co.
/// The Thomas and Betts Co.

RENEWAL PARTS



TYPE 17LS8A AND 17LS8B RELAYS

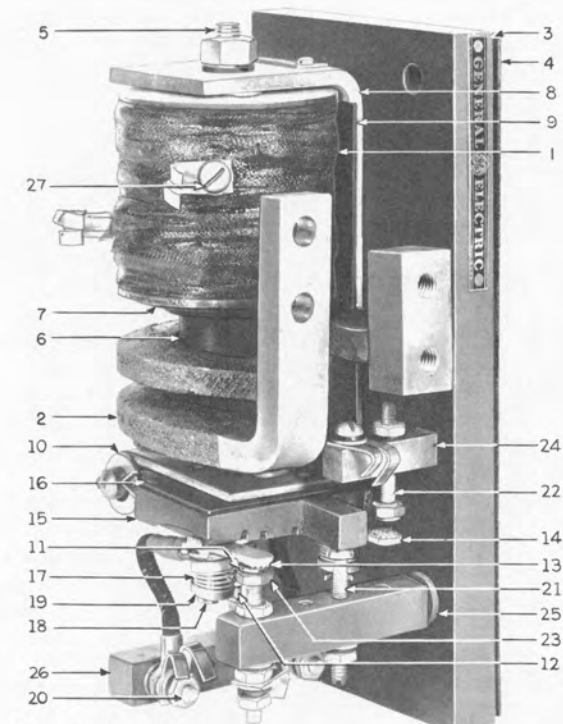

(PHOTO 817613)

Type 17LS8B relay

Note: The last number in the nameplate rating is the coil number. A letter following the last number indicates only that the apparatus has been set to trip at a certain value of current.

Example: Type 17LS8A1 requires operating Coil Cat. 2738643 and series coils Cat. 4731655G1

COILS

Coil Number	Operating Coil Ref. No. 1 1 Required Cat. No.	Series Coil Ref. No. 2 1 Required Cat. No.	Coil Number	Operating Coil Ref. No. 1 1 Required Cat. No.	Series Coil Ref. No. 2 1 Required Cat. No.
1	2738643	4731655G1	5	4739255	4731655G1
2	4739255	4731655G1	6	4739255	4731655G1
3	4739266	4731655G1	7	4739266	4731655G1
4	4739275	4731655G1			

When ordering renewal parts, give quantity, catalog number, description of each item required, and complete nameplate reading.



TYPE 17LS8A AND 17LS8B RELAYS

Ref. No.	Number Required for Type 17LS8-		Catalog Number	Description
	A	B		
3	1	1	4710435	Rubber washer for operating coil
	1		4731659	Base
4		1	6724232	Base
	1	1	2712393	Insulation plate for base
	2	2	205064	Wood screw fastening insulation plate to base, 6, 3/8 in. f h
5	1	1	2716605	Magnet core for coils
6	1	1	4715250	Insulation tube for magnet core
7	2	2	1430984	Insulation flange for series coil
	1	1	4715014	Spacer between series coil lead and base
	2	2	N37P16016B	Screw fastening series coil terminal base 10-32, 1 in. r h
	1	1	2432520	Fiber washer between coils
8	1	1	4756094	Frame with pivot pin for armature
9	1	1	4715013	Insulation shield between coils and frame
	2	2	66X695	Screw fastening insulation shield to frame (Parker Kalon Type "U", 4, 1/4 in. r h)
10	2	2	N37P21012B	Screw fastening frame to base 1/4 in. -20, 3/4 in. r h
	1		2712485	Armature with bushing and spring post
10		1	4709103	Armature with bushing and spring post
11	1	1	2712392	Bushing for armature
	1	1	729749	Tension spring with plug, for armature
12	1		4711454	Adjusting screw for tension spring
12		1	6700692	Adjusting screw for tension spring
13	1		2712500	Contact finger
		1	6728616G2	Contact finger with shunt (tip on shunt side)
14		1	6728616G1	Contact finger with shunt (tip on side opposite shunt)
15		1	4765788	Support for contact fingers
16		1	4704972	Insulation shield for support
		2	N37P16006B	Screw fastening finger support to armature 10-32, 3/8 in. r h
17	1		6721283	Compression spring for contact finger
17		2	170634	Compression spring for contact finger
18	1		6712228	Spring post for compression spring
18		2	4703610	Spring post for compression spring
19	2	4	1450952	Spring seat for compression spring
	1		4737001G4	Shunt with terminals, for contact finger
20	1		2712739	Screw fastening shunt to contact finger
	1		N37P16016B	Screw fastening shunt to post 10-32, 1 in. r h
20		2	N37P16020B	Screw fastening shunt to post 10-32, 1 1/4 in. r h
21	1	1	2711908	Stop screw for armature
22	1	1	9963477G3	Short stationary contact stud
23		1	9963477G10	Long stationary contact stud
24	1		4715245	Supporting post for Cat. 9963477G3
24		1	4712686	Supporting post for Cat. 9963477G3
25	1		4704616	Supporting post for stop screw
25		1	6712155	Supporting post for stop screw and Cat. 9963477G10
26	1		2716762	Supporting post for shunt
26		1	4709102	Supporting post for shunts
	1		4715251	Support for terminal
	2		N37P21012B	Screw fastening supporting post to base 1/4 in. -20, 3/4 in. r h
		3	N37P21010B	Screw fastening supporting post to base 1/4 in. -20, 1 5/8 in. r h
27		1	4731833P6	Screw fastening terminal to Cat. 4712686 (10-32)
	2	2	N37P16006B	Screw fastening terminal to operating coil 10-32, 3/8 in. r h
	1		N37P21016B	Screw fastening terminal to support, 1/4 in. -20, 1 in. r h
	A	B		

TYPE 17LS8A AND 17LS8B RELAYS

GEF-3034B

Note: The following items are steel unless otherwise specified.

PLAIN WASHERS

Catalog Number	Description
N402P9B	For No. 10 screw
N402P11B	For 1/4 in. screw
N401P13	For 3/8 in. screw, brass

LOCK WASHERS

Catalog Number	Description
N405P9P	For No. 10 screw (light)
N405P39P	For No. 10 screw (std)
N405P41P	For 1/4 in. screw
N405P43P	For 3/8 in. screw

NUTS

N210P16B	10-32, hex. std
N203P25B	3/8 in. -16, hex. std

COTTER PINS

N503P606B	1/16 in. by 3/8 in.
N503P910B	3/32 in. by 5/8 in.

WHEN YOU NEED SERVICE

IF YOU NEED TO REPAIR, recondition, or rebuild any electric apparatus, a G-E service shop near you is available day and night, seven days a week, for work in the shops or on your premises. Latest factory methods and genuine G-E renewal parts are used to maintain the original performance of your G-E equipment. For full information about these services, contact the nearest service shop or sales office listed below:

APPARATUS SERVICE SHOPS

Allentown, Pa. 672-676 E. Highland St.
 Appleton, Wisc. Midway Industrial Area,
 County Trunk, "P"
 Atlanta—Chamblee, Ga. 4639 Peachtree
 Indus. Blvd.
 Baltimore 30, Md. 920 E. Fort Ave.
 Boston—Medford 55, Mass. Mystic Valley Pkwy.
 Buffalo 11, N. Y. 318 Urban St.
 Charleston 28, W. Va. 306 MacCorkle Ave., S.E.
 Charlotte, N. C. 2328 Thrift Road
 Chicago 32, Ill. 4360 W. 47th St.
 Cincinnati 2, Ohio 444 W. Third St.
 Cleveland 4, Ohio 4966 Woodland Ave.
 Columbus 23, Ohio 2128 Eakin Rd.
 Corpus Christi, Texas 115 Busse St.
 Dallas 19, Texas 3202 Manor Way
 Davenport—Bettendorf, Ia. 1039 State St.
 Decatur, Ill. 2225 E. Logan St.
 Denver 5, Colo. 3353 Larimer St.
 Detroit 2, Mich. 5950 Third Ave.
 Houston 20, Texas 5534 Harvey Wilson Drive
 Indianapolis 22, Ind. 1740 W. Vermont St.
 Johnstown, Pa. 841 Oak St.
 Kansas City 8, Mo. 819 E. 19th St.
 Los Angeles 1, Calif. 6900 Stanford Ave.
 Louisville, Ky. 2014 New Main St.
 Midland, Tex. 3404 Bankhead Hwy.
 Milwaukee 3, Wisc. 940 W. St. Paul Ave.
 Minneapolis 12, Minn. 2025 49th Ave., N.
 New Orleans, La. 2815 N. Robertson St.
 New York 14, N. Y. 416 W. 13th St.
 Oakland, Calif. 1525 Peralta St.
 Philadelphia 24, Pa. 1040 E. Erie Ave.
 Pittsburgh 6, Pa. 6519 Penn Ave.
 Portland 10, Oregon 2727 N.W. 29th Ave.
 Richmond 24, Va. 1403 Ingram Ave.
 Roanoke, Va. 115 Albermarle St.
 Sacramento, Calif. 99 N. 17th St.
 St. Louis 10, Mo. 1115 East Road
 Salt Lake City 4, Utah. 301 S. Seventh West St.
 San Francisco 3, Calif. 1098 Harrison St.
 Seattle 4, Wash. 3422 First Ave., S.
 Southington, Conn. 53 Railroad Ave.
 Spokane 3, Wash. S. 155 Sherman St.
 Toledo 4, Ohio 1 So. St. Clair St.
 Wheeling, W. Va. 2050 National Rd.
 York, Pa. 54 N. Harrison St.
 Youngstown 5, Ohio 272 E. Indianola Ave.

APPARATUS SALES OFFICES

Abilene, Texas 442 Cedar St.
 Akron 8, Ohio 335 S. Main St.
 Albany 7, N. Y. 90 State St.
 Albuquerque, N. Mex. 323 Third St., S.W.
 Alexandria, La. 720 Murray St.
 Allentown, Pa. 1132 Hamilton St.
 Amarillo, Texas Amarillo Bldg.
 Appleton, Wisc. 531 W. College Ave.
 Atlanta 3, Ga. 1860 Peachtree Rd., N.W.
 Augusta, Ga. Masonic Bldg.
 Augusta, Me. 152 State St.
 Baltimore 1, Md. 111 Park Ave.
 Bangor, Maine 77 Central St.
 Baton Rouge 6, La. 3170 Florida Blvd.
 Battle Creek, Mich. 25 W. Michigan Ave.
 Beaumont, Texas 1385 Calder Ave.
 Billings, Mont. Rm. 816, 303 No. Broadway
 Binghamton, N. Y. 19 Chenango St.
 Birmingham 3, Ala. 1804 Seventh Ave., N.

Bismarck, N. Dak. 418 Rosser Ave.
 Bluefield, W. Va. 704 Bland St.
 Appalachian Bldg.
 Boise, Idaho 1524 Idaho St.
 Boston 1, Mass. 140 Federal St.
 Buffalo 3, N. Y. 535 Washington St.
 Butte, Mont. P.O. Box 836, 103 N. Wyoming St.
 Canton 2, Ohio 700 Tuscarawas St., W.
 Cedar Rapids, Iowa 210 Second St., S.E.
 Charleston 28, W. Va. 306 MacCorkle Ave., S.E.
 Charlotte 1, N. C. 112 S. Tryon St.
 Chattanooga 2, Tenn. 832 Georgia Ave.
 Chicago 80, Ill. P.O. Box 5970A, 840 S. Canal St.
 Cincinnati 2, Ohio 215 W. Third St.
 Cleveland 4, Ohio 4966 Woodland Ave.
 Columbia 1, S.C., P.O. Box 1434, 1420 Lady St.
 Columbus 15, Ohio 40 S. Third St.
 Corpus Christi, Texas 205 N. Chaparral
 Dallas 2, Texas 1801 N. Lamar St.
 Davenport—Bettendorf, Ia. 1039 State St.
 Dayton 2, Ohio 11 W. Monument Bldg.
 Dayton 9, Ohio. Avia. & Def.,
 2600 Far Hills Ave.
 Denver 2, Colo. 650 Seventeenth St.
 Des Moines 9, Iowa 505 W. Fifth Ave.
 Detroit 2, Mich. 700 Antoinette St.
 Duluth 2, Minn. 14 W. Superior St.
 Elmira, N. Y. Main and Woodlawn Aves.
 El Paso, Texas 215 No. Stanton
 Erie, Pa. 1001 State St.
 Eugene, Ore. 610 High St.
 Evansville 19, Ind. 123 N.W. Fourth St.
 Fairmont, W. Va. 310 Jacobs Bldg.,
 P.O. Box 1626
 Fergus Falls, Minn. 108 N. Court Ave. P.O. Box 197
 Flint 3, Mich. 653 S. Saginaw St.
 Fort Wayne 6, Ind. 3606 So. Calhoun St.
 Fort Worth 2, Tex. 408 W. Seventh St.
 Fort Worth, Tex. Avia. & Def.,
 6200 Camp Bowie Blvd.
 Fresno 1, Calif. 407 Patterson Bldg.
 Tulare and Fulton St.
 Grand Rapids 2, Mich. 425 Cherry St., SE
 Greensboro, N. C. 301 S. Elm St.
 Greenville, S. C. 108 W. Washington St.
 Gulfport, Miss. 207 Jo-Fran Bldg.
 Hagerstown, Md. Professional Arts Bldg.
 Hartford 5, Conn. 764 Asylum Ave.
 Houston 1, Texas 1312 Live Oak St.
 Indianapolis 4, Ind. 110 N. Illinois St.
 Jackson, Mich. 120 W. Michigan Ave.
 Jackson 1, Miss. 203 W. Capitol St.
 Jacksonville 2, Fla. 700 E. Union St.
 Jamestown, N. Y. P.O. Box 548, 2 Second St.
 Johnstown, Pa. 841 Oak St.
 Joplin, Mo. P.O. Box 948, 220½ W. Fourth St.
 Kalamazoo 3, Mich. 112 Parkway Ave.
 Kansas City 6, Mo. 106 W. Fourteenth St.
 Knoxville 08, Tenn. 602 S. Gay St.
 Lake Charles, La. 422 Seventh St.
 Lansing 8, Mich. 306 Michigan National Tower
 Lexington, Ky. First National Bank Bldg.
 Lincoln 8, Nebr. Sharpe Bldg., 206 S. 13th St.
 Little Rock, Ark. 103 W. Capitol Ave.
 Los Angeles 54, Calif. 212 N. Vignes St.
 Louisville 2, Ky. 455 S. Fourth St.
 Lubbock, Texas 3202 Avenue "A"
 Macon, Ga. 682 Cherry St.
 Madison 3, Wisc. 16 N. Carroll St.
 Manchester, N. H. 875 Elm St.

Medford, Ore., P.O. Box 1349, 205 W. Main St.
 Memphis 3, Tenn. 8 N. Third St.
 Miami 32, Fla. 25 S.E. Second Ave.
 Midwest City, Okla. Avia. & Def.,
 207 Post Off. Bldg.
 Milwaukee 3, Wisc. 940 W. St. Paul Ave.
 Minneapolis 3, Minn. 12 S. Sixth St.
 Mobile 13, Ala. 54 St. Joseph St.
 Nashville 3, Tenn. 234 Third Ave., N.
 Newark 2, N. J. 744 Broad St.
 New Haven 6, Conn. 129 Church St.
 New Orleans 12, La. 837 Gravier St.
 New York 22, N. Y. 570 Lexington Ave.
 New York Avia. & Def., Fed. Bldg.,
 N. Y. International Airport, Jamaica 30, N. Y.
 Niagara Falls, N. Y. 253 Second St.
 Norfolk 10, Va. 229 W. Bute St.
 Oakland 12, Calif. 409 Thirteenth St.
 Oklahoma City 2, Okla. 119 N. Robinson St.
 Omaha 2, Nebr. 409 S. Seventeenth St.
 Pasco, Wash. 824 W. Lewis St.
 Peoria 2, Ill. 309 Jefferson Bldg.
 Philadelphia 2, Pa. 1405 Locust St.
 Phoenix, Ariz. P.O. Box 4037, 303 Luhrs Tower
 Pittsburgh 22, Pa. The Oliver Bldg., Mellon Sq.
 Portland 7, Ore. 920 S.W. Sixth Ave.
 Providence 3, R. I. Industrial Trust Bldg.
 Raleigh, N. C. 336 Fayetteville St.
 Reading, Pa. 31 N. Sixth St.
 Richmond 17, Va. 700 E. Franklin St.
 Riverside, Calif. 3570 Ninth St.
 Roanoke 16, Va. 920 S. Jefferson St.
 Rochester 4, N. Y. 89 E. Ave.
 Rockford, Ill. 110 S. First St.
 Rutland, Vt. 38½ Center St.
 Sacramento 14, Calif. 626 Forum Bldg.
 Saginaw, Mich. Second National Bank Bldg.
 St. Louis 1, Mo. 818 Olive St.
 Salt Lake City 9, Utah 200 S. Main St.
 San Antonio 5, Texas 434 So. Main Ave.
 San Diego 1, Calif. 1240 Seventh Ave.
 San Francisco 6, Calif. 235 Montgomery St.
 San Jose 10, Calif. 460 Park Ave.
 Savannah, Ga. 4 E. Bryan St.
 Seattle 4, Wash. 710 Second Ave.
 Seattle 8, Wash. Avia. & Def., 220 Dawson St.
 Shreveport; La. 910 Shelby Bldg.
 Sioux City 13, Iowa. 572 Orpheum Electric Bldg.
 South Bend 1, Ind. 112 W. Jefferson Blvd.
 Spokane 4, Wash. S. 162 Post St.
 Springfield, Ill. 607 E. Adams St.
 Springfield 3, Mass. 1387 Main St.
 Stockton, Calif. 11 So. San Joaquin St.
 Syracuse 6, N. Y. 3532 James St.
 Tacoma 1, Wash. 1202 Washington Bldg.
 Tampa 6, Fla. 1206 North A St.
 Toledo 4, Ohio 420 Madison Ave.
 Trenton 8, N. J. 214 E. Hanover St.
 Tucson, Ariz. P.O. Box 710, 650 N. Sixth Ave.
 Tulsa 3, Okla. 320 S. Boston Ave.
 Utica 2, N. Y. 258 Genesee St.
 Washington 5, D. C. 777-14th St., N.W.
 Waterloo, Iowa 206 W. 4th St.
 Wenatchee, Wash. 328 N. Wenatchee Ave.
 Wheeling, W. Va. 40 Fourteenth St.
 Wichita 2, Kan. 200 E. First St.
 Williamston, N. C. 115 E. Main St.
 Worcester 5, Mass. 288 Grove St.
 York, Pa. 56 N. Harrison St.
 Youngstown 5, Ohio 272 E. Indianola Ave.

Hawaii: American Factors, Ltd., P. O. Box 3230, Honolulu 1 Canada: Canadian General Electric Company, Ltd., Toronto

LOCOMOTIVE AND CAR EQUIPMENT DEPARTMENT, GENERAL ELECTRIC COMPANY, ERIE, PA.

RENEWAL PARTS

TYPE 17CM12 CONTACTORS

Forms B, J, L, S, AD, AL, AM, AT, AV, AW, AY, BR, BW, and CA

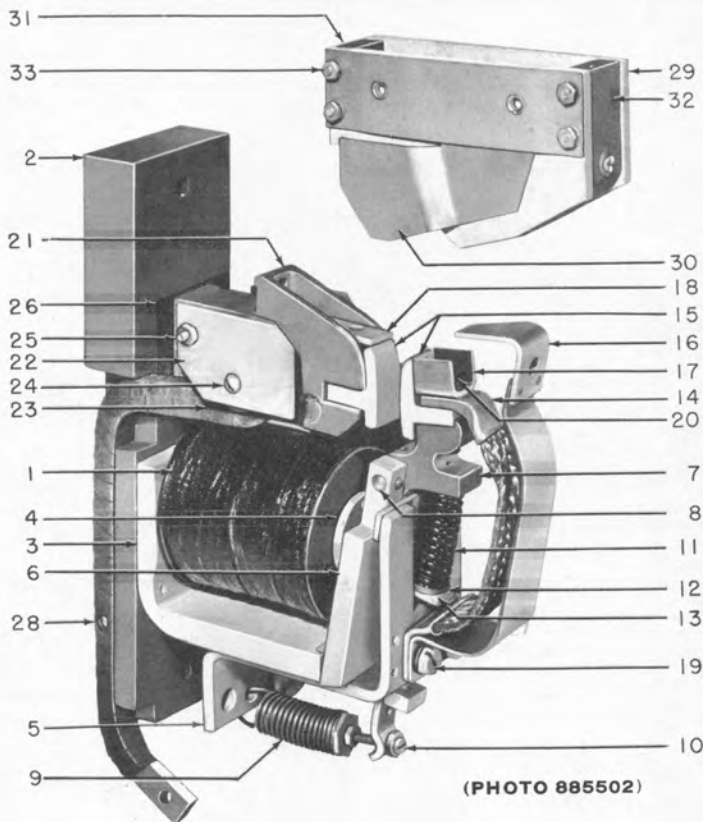

(PHOTO 885502)

Type 17CM12L contactor

NOTE:- The last number in the nameplate rating is the operating coil number.

EXAMPLE:- Type 17CM12B23 indicates that operating coil Cat. 4739326 is required.

Ref. No. 1 - OPERATING COILS - (1 Required)

Coil No.	Cat. No.	Coil No.	Cat. No.	Coil No.	Cat. No.	Coil No.	Cat. No.
2	‡2738575	11	‡2738679	23	4739326	36	4739484
3	‡2738576	15	‡2738770	27	4739345	37	8827023
4	‡2738585	16	‡4739110	29	4739364	38	8827058
5	2738588	17	‡4739131	30	4739369	39	8860451
6	‡2738604	18	‡2738576	31	4739382	42	8860471
7	2738605	19	‡2738701	33	4739368	43	4739488
10	‡2738701	20	‡4739235	34	4739366		

‡ See page 5 for table of new design operating coils.

When ordering renewal parts, give quantity, catalog number, description of each item required, and complete nameplate reading.



TYPE 17CM12 CONTACTORS

Ref. No.	Number Required for Type 17CM12-															Cat. No.	Description
	B	J	L	S	AD	AL	AM	AT	AV	AW	AY	BR	BW	CA			
	1	1	1	1	1	1	1	1	1	1	1	1				4710413	Rubber washer between operating coil and magnet frame
		2	2										2	2		207248	Screw fastening operating coil to magnet frame, 8-36
2	1	1	1	1	1							1				4710370	Supporting block
2						1							1	1		6716709	Supporting block
2							1									4711745	Supporting block
2								1	1	1	1					6712042	Supporting block
3	1	1	1	1	1	1	1	1	1	1	1	1	1	1	1	4768834	Magnet frame
	2	2	2	2	2	2	2	2	2	2	2	2	2	2	2	187184	Screw fastening magnet frame to supporting block, 5/16 in.-18
	1															6703437	Insulation between operating coil and magnet frame, for Type 17CM12B10 and 17CM12B19 Contactors only
	2															91X733	Screw fastening insulation to magnet frame
4	1	1	1	1	1	1	1	1	1	1	1	1	1	1	1	4710372	Magnet core for operating coil
	1	1	1	1	1	1	1	1	1	1	1	1	1	1	1	143997	Screw fastening magnet core to magnet frame, 3/8 in. 16
	1					1							1	1		4710507	Sleeve for magnet core, for Type 17CM12B3, -B5, -B18, -AL38, -BW37, and -CA37 Contactors only
5	1	1	1	1	1	1	1	1	1	1	1	1	1	1	1	4737935AB	Armature stop
	2	2	2	2	2	2	2	2	2	2	2	2	2	2	2	46X777	Screw fastening armature stop to magnet frame, 1/4 in.-20
	1	1	1	1	1	1	1		1	1	1		1	1		108X19	Armature with contact lever and hinge pin
								1				1				162X88	Armature with contact lever and hinge pin
6	1	1	1	1	1	1	1		1	1	1		1	1		4768852G1	Armature with spring bracket
6								1				1				960792G2	Armature with spring bracket
7	1	1	1	1	1	1	1	1	1	1	1	1	1	1	1	8802317	Contact lever with bushing
	1	1	1	1	1	1	1	1	1	1	1	1	1	1	1	47504840	†Bushing for contact lever
8	1	1	1	1	1	1	1	1	1	1	1	1	1	1	1	6702237	Hinge pin for contact lever
	2	2	2	2	2	2	2	2	2	2	2	2	2	2	2	89X62	Rivet for hinge pin
9	1		1	1	1	1	1	1	1	1			1	1		4735918	§Tension spring with plug, for armature
9	1		1	1				1	1	1						6724926	§Tension spring with plug, for armature
9		1														8823898	Tension spring with plug, for armature
9												1	1			4735923	Tension spring with plug, for armature
10	1		1	1	1	1	1	1	1	1	1	1	1	1	1	6700342	Adjusting screw for tension spring, 10-32
10		1														6706033	Adjusting screw for tension spring, 10-32
11	1			1			1	1	1							6724971	Compression spring for contact lever
11		1									1	1				4731901	Compression spring for contact lever
11			1			1				1						6724998	Compression spring for contact lever
11					1											4735919	Compression spring for contact lever
11												1	1			4734900	Compression spring for contact lever
12	1	1	1	1	1	1	1	1	1	1	1	1	1	1	1	4710379	Spring seat for compression spring
13	4	4	4	4	4	4	4	4	4	4	4	4	4	4	4	4710450	Shim for spring seat
14	1	1	1	1	1				1	1	1	1	1	1	1	4767443	Flexible shunt for contact lever
14						1	1	1								4731183	Flexible shunt for contact lever
15	2								2							4712980	Contact tip
15		2								2	2					6703513	Contact tip
15			2			2				2			2	2		6701049	Contact tip
15				2			2	2								4715959	Contact tip
16	1	1	1		1	1			1	1	1	1	1	1	1	4710825	Arcing horn with spring

† Bushing should be burnished to size after assembly by using tool Cat. No. 4735725P1.

§ Tension spring Cat. 6724926 is for use only on contactors equipped with interlocks having three or more normally closed contacts. Tension spring Cat. 4735918 should be used for all other applications.

TYPE 17CM12 CONTACTORS

GEF-3041D

Ref. No.	Number Required for Type 17CM12-															Cat. No.	Description
	B	J	L	S	AD	AL	AM	AT	AV	AW	AY	BR	BW	CA			
16				1			1	1								4715961	Arcing horn with spring
17	1	1	1		1	1			1	1	1	1	1	1		6712196	Arcing horn for movable contact tip
18	1	1	1		1	1			1	1	1	1	1	1		6712197	Arcing horn for stationary contact tip
19	2	2	2	2	2	2	2	2	2	2	2	2	2	2		126872	Screw fastening shunt and arcing horn spring to armature stop 5/16 in.-18
20	2	2	2		2	2			2	2	2	2	2	2		91X103	Screw fastening contact tip in position 5/16 in.-18
20				1			1	1								91X103	Screw fastening movable contact tip to contact lever 5/16 in.-18
				1			1	1								82X219	Screw fastening stationary contact tip to support 5/16 in.-18
21	1	1	1	1	1							1	1	1		4755868	Stationary contact support with blowout coil, insulated core, and pole pieces
21						1	1									4756848	Stationary contact support with blowout coil, insulated core, and pole pieces
21								1								113X8	Stationary contact support with blowout coil, insulated core, and pole pieces
21									1	1	1					113X6	Stationary contact support with blowout coil, insulated core, and pole pieces
	1	1	1	1	1	1	1	1	1	1	1	1	1	1		4750508	Insulated core for blowout coil
	1	1	1	1	1	1	1	1	1	1	1	1	1	1		4710381	Core for blowout coil
	1	1	1	1	1	1	1	1	1	1	1	1	1	1		4715482	Insulation tube for core
	2	2	2	2	2	2	2	2	2	2	2	2	2	2		4715483	Spool end for core
22	2	2	2	2	2	2	2	2	2	2	2	2	2	2		4710384	Pole piece for blowout coil
23	2	2	2	2	2	2	2	2	2	2	2	2	2	2		4710809	Insulation between pole piece and stationary contact support
24	2	2	2	2	2	2	2	2	2	2	2	2	2	2		105113	Screw fastening pole piece to core 10-32
25	1	1	1	1	1	1	1	1	1	1	1	1	1	1		134976	Screw fastening pole piece to stationary contact support 10-32
	1	1	1	1	1	1	1	1	1	1	1	1	1	1		4710386	Insulation tube for Cat. 134976
	2	2	2	2	2	2	2	2	2	2	2	2	2	2		4710385	Spacer between pole piece and stationary contact support
26	1	1	1	1	1								1			4710409	Insulation shield between stationary contact support and supporting block (L shaped)
26			1			1				1			1	1		4711837	Insulation shield between stationary contact support and supporting block (flat)
26					1	1	1	1	1	1			1	1		6712046	Insulation shield between stationary contact support and supporting block (L shaped)
	2	2	2	2	2	2	2	2	2	2	2	2	2	2		187184	Screw fastening stationary contact support to supporting block 5/16 in.-18
28	1	1	1	1	1	1	1					1	1	1		15988	Wood screw fastening blowout coil lead to supporting block
								1	1	1	1					46X777	Screw fastening blowout coil terminal block to supporting block 1/4 in.-20
	1	1	1		1	1			1	1	1	1	1			2728651G3	Arc chute
				1			1	1						1		4745353G1	Arc chute
29	2	2	2		2	2			2	2	2	2	2			4704533	Side plate for arc chute
29				2			2	2						2		4715962	Side plate for arc chute
30	1	1	1		1	1			1	1	1	1	1			4710454	Pole piece with insulation, left-hand facing front of contactor
30				1			1	1						1		4756736	Pole piece with insulation, left-hand facing front of contactor

TYPE 17CM12 CONTACTORS

Ref. No.	Number Required for Type 17CM12-														Cat. No.	Description
	B	J	L	S	AD	AL	AM	AT	AV	AW	AY	BR	BW	CA		
	1	1	1		1	1			1	1	1	1	1		4710453	Pole piece with insulation, right-hand facing front of contactor
				1			1	1						1	4756735	Pole piece with insulation, right-hand facing front of contactor
31	1	1	1		1	1			1	1	1	1	1		4755209	Short spacing block with latch pin
31				1			1	1						1	4756737	Short spacing block with latch pin
32	1	1	1		1	1			1	1	1	1	1		4755210	Long spacing block with latch pin
32				1			1	1						1	4756738	Long spacing block with latch pin
				1			1	1						1	2710147	Latch pin for long spacing block 10-32
33	4	4	4		4	4			4	4	4	4	4	1	4715965	Arc suppressor plate
33				6			6	6						6	198709	Clamping screw for arc chute 10-32
														6	200487	Clamping screw for arc chute 10-32
	B	J	L	S	AD	AL	AM	AT	AV	AW	AY	BR	BW	CA		

NOTE:- The following items are steel unless otherwise specified.

PLAIN WASHERS

Cat. No.	Description
155830	For No. 8 screw
150279	For No. 10 screw
143974	For 1/4 in. screw
145598	For 5/16 in. screw, 5/8 in. O.D.
147674	For 5/16 in. screw, 7/8 in. O.D.
141259	For 3/8 in. screw

LOCK WASHERS

Cat. No.	Description
54X473	For No. 8 screw
54X441	For No. 10 screw
71X749	For No. 10 screw, Shakeproof
30X562	For 1/4 in. screw
6X814	For 5/16 in. screw
6X815	For 3/8 in. screw

NUTS

Cat. No.	Description
145996	10-32, hex. std
151175	10-32, hex. std, brass
141255	3/8 in.-16, hex std

Two designs of operating coils have been furnished for the Type 17CM12 Contactor. The first design of operating coil Fig. 1 has round spool flanges at both ends, the second design Fig. 2 has one round and one offset spool flange which provides for fastening to the contactor frame by means of two 8-36, 1/2 in. r.h. screws Cat. 207248. This design prevents breaking connections by the turning of the operating coil.

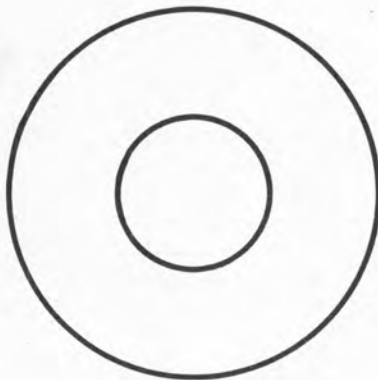

Fig. 1

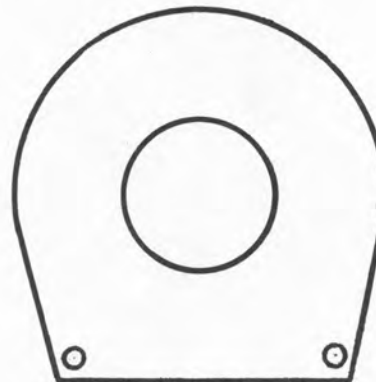
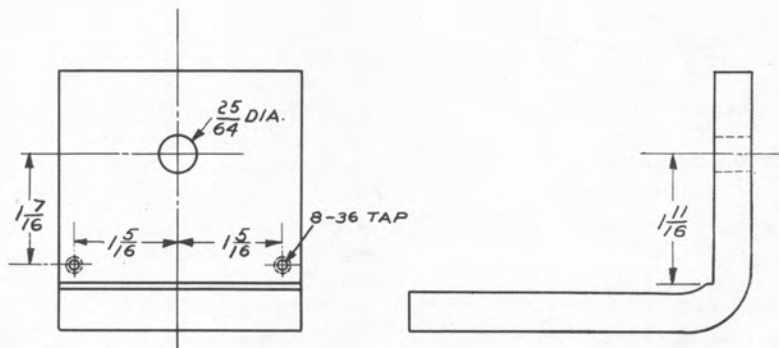

Fig. 2

(ART PBA-76760)

Operating Coils listed in this table are interchangeable, except that the contactor frame must be machined in accordance with Fig. 3 before the operating coils of the second design can be applied. The rubber washers used with operating coils of the first design Fig. 1 are not required for the second design Fig. 2.

Operating Coil Fig. 1 Design	Cat. No. Fig. 2 Design	Operating Coil Fig. 1 Design	Cat. No. Fig. 2 Design	Operating Coil Fig. 1 Design	Cat. No. Fig. 2 Design
2738575	4739326	2738604	4739367	4739110	4739414
2738576	4739327	2738701	4739328	4739131	4739382
2738585	4739366	2738679	4739368	4739235	4739369
		2738770	4739364		



(ART PBA-76764)

Fig. 3

1. Remove partial radius in bend of frame as shown.
2. Drill and tap frame locating two tapped holes from the center of the present 25/64 in. diam hole in frame.
3. Place new design coil retainer furnished with coil between core body and coil spool with long end inside coil and short end under core head.

TYPE 17CM12 CONTACTORS

INDEX OF CATALOG NUMBERS

Catalog identifications in this index are arranged in order, reading from *left to right*, first alphabetically according to the prefix letter or letters, if used, and second numerically.

In this index all numbers with a letter prefix will precede those without prefixes.

The number of letters or digits does not affect placement in the table, thus A1999999 will precede A2, and ZZ9999999 will precede Cat. No. 1 (number without a prefix). Letters take precedence over numbers so that Cat. No. 26F1 will precede Cat. No. 261.

Cat. No.	Page	Cat. No.	Page	Cat. No.	Page	Cat. No.	Page
105113-----	3	2738770-----	1,5	4735919-----	2	4768852G1----	2
108X19-----	2	30X562-----	4	4735923-----	2	54X441-----	4
113X6-----	3	46X777-----	2,3	4737935AB----	2	54X473-----	4
113X8-----	3	4704533-----	3	4739110-----	1,5	6X814-----	4
126872-----	3	4710370-----	2	4739131-----	1,5	6X815-----	4
134976-----	3	4710372-----	2	4739235-----	1,5	6700342-----	2
141255-----	4	4710379-----	2	4739326-----	1,5	6701049-----	2
141259-----	4	4710381-----	3	4739327-----	5	6702237-----	2
143974-----	4	4710384-----	3	4739328-----	5	6703437-----	2
143997-----	2	4710385-----	3	4739345-----	1	6703513-----	2
145598-----	4	4710386-----	3	4739364-----	1,5	6706033-----	2
145996-----	4	4710409-----	3	4739366-----	1,5	6712042-----	2
147674-----	4	4710413-----	2	4739367-----	5	6712046-----	3
150279-----	4	4710450-----	2	4739368-----	1,5	6712196-----	3
151175-----	4	4710453-----	4	4739369-----	1,5	6712197-----	3
155830-----	4	4710454-----	3	4739382-----	1,5	6716709-----	2
15988-----	3	4710507-----	2	4739414-----	5	6724926-----	2
162X88-----	2	4710809-----	3	4739484-----	1	6724971-----	2
187184-----	2,3	4710825-----	2	4739488-----	1	6724998-----	2
198709-----	4	4711745-----	2	4745353G1----	3	71X749-----	4
200487-----	4	4711837-----	3	47504840-----	2	82X219-----	3
2072248-----	2	4712980-----	2	4750508-----	3	8802317-----	2
2710147-----	4	4713183-----	2	4755209-----	4	8823898-----	2
2728651G3----	3	4715482-----	3	4755210-----	4	8827023-----	1
2738575-----	1,5	4715483-----	3	4755868-----	3	8827058-----	1
2738576-----	1,5	4715959-----	2	4756735-----	4	8860451-----	1
2738585-----	1,5	4715961-----	3	4756736-----	3	8860471-----	1
2738588-----	1	4715962-----	3	4756737-----	4	89X62-----	2
2738604-----	1,5	4715965-----	4	4756738-----	4	91X103-----	3
2738605-----	1	4731901-----	2	4756848-----	3	91X733-----	2
2738679-----	1,5	4734900-----	2	4767443-----	2	960792G2-----	2
2738701-----	1,5	4735918-----	2	4768834-----	2		

WHEN YOU NEED SERVICE

IF YOU NEED TO REPAIR, recondition, or rebuild any electric apparatus, a G-E service shop near you is available day and night, seven days a week, for work in the shops or on your premises. Latest factory methods and genuine G-E renewal parts are used to maintain the original performance of your G-E equipment. For full information about these services, contact the nearest service shop or sales office listed below:

APPARATUS SERVICE SHOPS

Allentown, Pa. 672-676 E. Highland St.
 Appleton, Wisc. Midway Industrial Area,
 County Trunk, "P"
 Atlanta—Chamblee, Ga. 4639 Peachtree
 Indus. Blvd.
 Baltimore 30, Md. 920 E. Fort Ave.
 Boston—Medford 55, Mass. Mystic Valley Pkwy.
 Buffalo 11, N. Y. 318 Urban St.
 Charleston 28, W. Va. 306 MacCorkle Ave., S.E.
 Charlotte, N. C. 2328 Thrift Road
 Chicago 32, Ill. 4360 W. 47th St.
 Cincinnati 2, Ohio 444 W. Third St.
 Cleveland 4, Ohio 4966 Woodland Ave.
 Columbus 23, Ohio 2128 Eakin Rd.
 Corpus Christi, Texas 115 Busse St.
 Dallas 19, Texas 3202 Manor Way
 Davenport—Bettendorf, Ia. 1039 State St.
 Decatur, Ill. 2225 E. Logan St.
 Denver 5, Colo. 3353 Larimer St.
 Detroit 2, Mich. 5950 Third Ave.
 Houston 20, Texas 5534 Harvey Wilson Drive
 Indianapolis 22, Ind. 1740 W. Vermont St.
 Johnstown, Pa. 841 Oak St.
 Kansas City, Mo. 3525 Gardner Ave.
 Los Angeles 1, Calif. 6900 Stanford Ave.
 Louisville, Ky. 2014 New Main St.
 Midland, Tex. 3404 Bankhead Hwy.
 Milwaukee 3, Wisc. 940 W. St. Paul Ave.
 Minneapolis 12, Minn. 2025 49th Ave., N.
 New Orleans, La. 2315 N. Robertson St.
 New York—N. Bergen, N. J. 6001 Tonnelle Ave.
 Oakland, Calif. 1525 Peralta St.
 Philadelphia 24, Pa. 1040 E. Erie Ave.
 Pittsburgh 6, Pa. 6519 Penn Ave.
 Portland 10, Oregon 2727 N.W. 29th Ave.
 Richmond 24, Va. 1403 Ingram Ave.
 Roanoke, Va. 115 Albermarle St.
 Sacramento, Calif. 99 N. 17th St.
 St. Louis 10, Mo. 1115 East Road
 Salt Lake City 4, Utah 301 S. Seventh West St.
 San Francisco 3, Calif. 1098 Harrison St.
 Seattle 4, Wash. 3422 First Ave., S.
 Southington, Conn. 53 Railroad Ave.
 Spokane 3, Wash. S. 155 Sherman St.
 Tampa 1, Fla. P.O. Box 1245,
 Naval Indus. Res. Shipyard
 Toledo 4, Ohio 1 So. St. Clair St.
 Wheeling, W. Va. 2050 National Rd.
 York, Pa. 54 N. Harrison St.
 Youngstown 5, Ohio 272 E. Indianola Ave.

APPARATUS SALES OFFICES

Abilene, Texas 442 Cedar St.
 Akron 8, Ohio 335 S. Main St.
 Albany 7, N. Y. 90 State St.
 Albuquerque, N. Mex. 323 Third St., S.W.
 Alexandria, La. 720 Murray St.
 Allentown, Pa. 1132 Hamilton St.
 Amarillo, Texas Amarillo Bldg.
 Appleton, Wisc. 531 W. College Ave.
 Atlanta 3, Ga. 1860 Peachtree Rd., N.W.
 Augusta, Ga. Masonic Bldg.
 Augusta, Me. 152 State St.
 Baltimore 1, Md. 111 Park Ave.
 Bangor, Maine 77 Central St.
 Baton Rouge 6, La. 3170 Florida Blvd.
 Battle Creek, Mich. 25 W. Michigan Ave.
 Beaumont, Texas 1385 Calder Ave.
 Billings, Mont. Rm. 816, 303 N. Broadway
 Binghamton, N. Y. 19 Chenango St.

Birmingham 3, Ala. 1804 Seventh Ave., N.
 Bismarck, N. Dak. 418 Rosser Ave.
 Bluefield, W. Va. 704 Bland St.
 Appalachian Bldg.
 Boise, Idaho 1524 Idaho St.
 Boston 1, Mass. 140 Federal St.
 Buffalo 3, N. Y. 535 Washington St.
 Butte, Mont. P.O. Box 836, 103 N. Wyoming St.
 Canton 2, Ohio 700 Tuscarawas St., W.
 Cedar Rapids, Iowa 210 Second St., S.E.
 Charleston 28, W. Va. 306 MacCorkle Ave., S.E.
 Charlotte 1, N. C. 112 S. Tryon St.
 Chattanooga 2, Tenn. 832 Georgia Ave.
 Chicago 80, Ill. P.O. Box 5970A, 840 S. Canal St.
 Cincinnati 2, Ohio 215 W. Third St.
 Cleveland 4, Ohio 4966 Woodland Ave.
 Columbia 1, S.C., P.O. Box 1434, 1420 Lady St.
 Columbus 15, Ohio 40 S. Third St.
 Corpus Christi, Texas 205 N. Chaparral
 Dallas 2, Texas 1801 N. Lamar St.
 Davenport—Bettendorf, Ia. 1039 State St.
 Dayton 2, Ohio 11 W. Monument Bldg.
 Dayton 9, Ohio Avia. & Def.,
 2600 Far Hills Ave.
 Denver 2, Colo. 650 Seventeenth St.
 Des Moines 9, Iowa 505 W. Fifth Ave.
 Detroit 2, Mich. 700 Antoinette St.
 Duluth 2, Minn. 14 W. Superior St.
 Elmira, N. Y. Main and Woodlawn Aves.
 El Paso, Texas 215 No. Stanton
 Erie, Pa. 1001 State St.
 Eugene, Ore. Cascade Bldg., 1170 Pearl St.
 Evansville 19, Ind. 123 N.W. Fourth St.
 Fairmont, W. Va. 310 Jacobs Bldg.,
 P.O. Box 1626
 Fergus Falls, Minn. 108 N. Court Ave. P.O. Box 197
 Flint 3, Mich. 653 S. Saginaw St.
 Fort Wayne 6, Ind. 3606 So. Calhoun St.
 Fort Worth 2, Tex. 408 W. Seventh St.
 Fort Worth, Tex. Avia. & Def.,
 6200 Camp Bowie Blvd.
 Fresno 1, Calif. 407 Patterson Bldg.,
 Tulare and Fulton St.
 Grand Rapids 2, Mich. 425 Cherry St., SE
 Greensboro, N. C. 301 S. Elm St.
 Greenville, S. C. 108 W. Washington St.
 Gulfport, Miss. 207 Jo-Fran Bldg.
 Hagerstown, Md. Professional Arts Bldg.
 Hartford 5, Conn. 764 Asylum Ave.
 Houston 1, Texas 1312 Live Oak St.
 Indianapolis 4, Ind. 110 N. Illinois St.
 Jackson, Mich. 120 W. Michigan Ave.
 Jackson 1, Miss. 203 W. Capital St.
 Jacksonville 2, Fla. 700 E. Union St.
 Jamestown, N. Y. P.O. Box 548, 2 Second St.
 Johnstown, Pa. 841 Oak St.
 Joplin, Mo. P.O. Box 948, 220½ W. Fourth St.
 Kalamazoo 3, Mich. 112 Parkway Ave.
 Kansas City 6, Mo. 106 W. Fourteenth St.
 Knoxville 16, Tenn. 1301 Hannah Ave.
 Lake Charles, La. 422 Seventh St.
 Lansing 8, Mich. 306 Michigan National Tower
 Lexington, Ky. First National Bank Bldg.
 Lincoln 8, Nebr. Sharpe Bldg., 206 S. 13th St.
 Little Rock, Ark. 103 W. Capital Ave.
 Los Angeles 54, Calif. 212 N. Vignes St.
 Louisville 2, Ky. 455 S. Fourth St.
 Lubbock, Texas 3302 Avenue "A"
 Macon, Ga. 682 Cherry St.
 Madison 3, Wisc. 16 N. Carroll St.
 Manchester, N. H. 875 Elm St.

Medford, Ore., P.O. Box 1349, 107 E. Main St.
 Memphis 3, Tenn. 8 N. Third St.
 Miami 32, Fla. 25 S.E. Second Ave.
 Midwest City, Okla. Avia. & Def.,
 207 Post Off. Bldg.
 Milwaukee 3, Wisc. 940 W. St. Paul Ave.
 Minneapolis 3, Minn. 12 S. Sixth St.
 Mobile 13, Ala. 54 St. Joseph St.
 Nashville 3, Tenn. 234 Third Ave., N.
 Newark 2, N. J. 744 Broad St.
 New Haven 6, Conn. 129 Church St.
 New Orleans 12, La. 837 Gravier St.
 New York 22, N. Y. 570 Lexington Ave.
 New York Avia. & Def., Fed. Bldg.,
 N. Y. International Airport, Jamaica 30, N. Y.
 Niagara Falls, N. Y. 253 Second St.
 Norfolk 10, Va. 229 W. Bute St.
 Oakland 12, Calif. 409 Thirteenth St.
 Oklahoma City 2, Okla. 119 N. Robinson St.
 Omaha 2, Nebr. 409 S. Seventeenth St.
 Pasco, Wash. 824 W. Lewis St.
 Peoria 2, Ill. 309 Jefferson Bldg.
 Philadelphia 2, Pa. 1405 Locust St.
 Phoenix, Ariz. P.O. Box 4037, 303 Luhrs Tower
 Pittsburgh 22, Pa. The Oliver Bldg., Mellon Sq.
 Portland 7, Ore. 920 S.W. Sixth Ave.
 Providence 3, R. I. Industrial Trust Bldg.
 Raleigh, N. C. Room 401, 16 W. Martin St.
 Reading, Pa. 31 N. Sixth St.
 Richmond 17, Va. 700 E. Franklin St.
 Riverside, Calif. 3570 Ninth St.
 Roanoke 16, Va. 920 S. Jefferson St.
 Rochester 4, N. Y. 89 E. Ave.
 Rockford, Ill. 110 S. First St.
 Rutland, Vt. 38½ Center St.
 Sacramento 14, Calif. 626 Forum Bldg.
 Saginaw, Mich. Second National Bank Bldg.
 St. Louis 1, Mo. 818 Olive St.
 Salt Lake City 9, Utah 200 S. Main St.
 San Antonio 5, Texas 434 So. Main Ave.
 San Diego 1, Calif. 1240 Seventh Ave.
 San Francisco 6, Calif. 235 Montgomery St.
 San Jose 10, Calif. 460 Park Ave.
 Savannah, Ga. 4 E. Bryan St.
 Seattle 4, Wash. 710 Second Ave.
 Seattle 8, Wash. Avia. & Def., 220 Dawson St.
 Shreveport, La. 206 Beck Bldg.
 Sioux City 13, Iowa 572 Orpheum Electric Bldg.
 South Bend 1, Ind. 112 W. Jefferson Blvd.
 Spokane 4, Wash. S. 162 Post St.
 Springfield, Ill. 607 E. Adams St.
 Springfield 3, Mass. 1387 Main St.
 Stockton, Calif. 11 So. San Joaquin St.
 Syracuse 6, N. Y. 3532 James St.
 Tacoma 1, Wash. 1202 Washington Bldg.
 Tampa 6, Fla. 1206 North A St.
 Toledo 4, Ohio 420 Madison Ave.
 Trenton 8, N. J. 214 E. Hanover St.
 Tucson, Ariz. P.O. Box 710, 650 N. Sixth Ave.
 Tulsa 3, Okla. 320 S. Boston Ave.
 Utica 2, N. Y. 258 Genesee St.
 Washington 5, D. C. 777-14th St., N.W.
 Waterloo, Iowa 206 W. 4th St.
 Wenatchee, Wash. 328 N. Wenatchee Ave.
 Wheeling, W. Va. 40 Fourteenth St.
 Wichita 2, Kan. 200 E. First St.
 Williamston, N. C. 115 E. Main St.
 Worcester 5, Mass. 288 Grove St.
 York, Pa. 56 N. Harrison St.
 Youngstown 5, Ohio 272 E. Indianola Ave.

RENEWAL PARTS



TYPE 17LC24A, -B AND -C RELAY

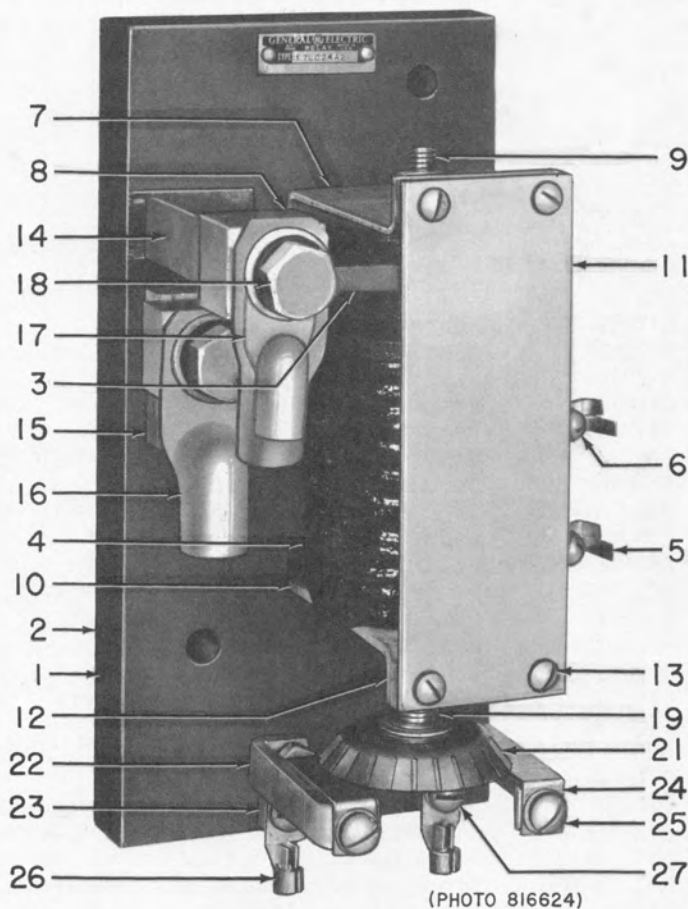

Type 17LC24A2 relay

NOTE: The last number in the nameplate rating is the coil number. A letter following the last number indicates only that the apparatus has been set to trip at a certain value of current.

EXAMPLE: 17LC24C1A requires Series Coil Cat. No. 6721534G1, and Shunt Coil Cat. No. 2738544.

Coils, 1 of Each Required

Coil No.	Series Coil Ref. 3 Cat. No.	Shunt Coil with Washer Ref. 4 Cat. No.
1	6721534G1	2738544
2	6721575G1	2738613
3	6721534G1	2738613
4	6721534G1	2738669

When ordering renewal parts, give quantity, catalog number, description of each item required, and complete nameplate reading.

TYPE 17LC24A, -B AND -C RELAY

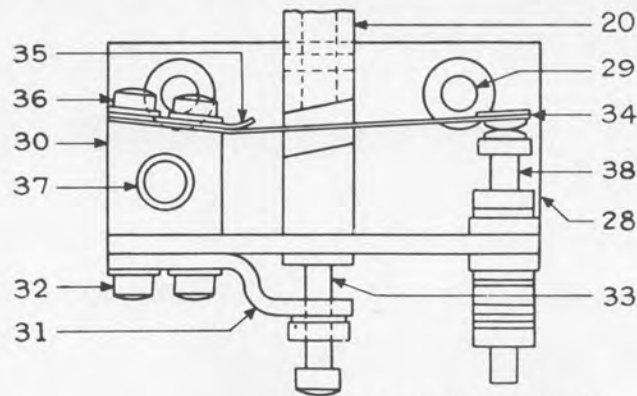

(NEG. PBA 70546)

Contact details for type 17LC24C1 relay

Ref. No.	No. Req. for Type 17LC24			Cat. No.	Description
	A	B	C		
1	1	1	1	6713057	Rubber washer for shunt coil
1	1	1		6721536	Base
2			1	6724445	Base
2	1	1		6710737	Insulation shield for base
2			1	6712669	Insulation shield for base
5	4	4	4	195842	Wood screw fastening insulation shield to base, 6, 1/2 in. fh
6	2	2	2	434048	Terminal for shunt coil
7	2	2	2	N37P16006B	Terminal screw for shunt coil, 10-32, 3/8 in. r.h.
7	1	1		4759045	End frame with core and guide tube
7			1	6724447G2	End frame with core and guide tube
8	2	2	2	6710713	Insulation washer for coils, 3 3/4 in. O.D.
	1	1	1	6710712	Insulation washer for coils, 2 in. O.D.
	2	2	2	6710711	Shim between coils
	1	1	1	6710709	Insulation sleeve for guide tube
9	1	1	1	6710701	Adjusting screw for series coil core
10	1	1	1	4702990	End frame, contact end
	4	4	4	N37P16014B	Screw fastening end frame to base, 10-32, 7/8 in. r.h.
11	1	1	1	6710706	Side frame
12	2	2		12D129	Spacer between side frame and end frame
12			2	6716252	Spacer between side frame and end frame
13	4	4		N37P16010B	Screw fastening side frame to end frame, 10-32, 5/8 in. r.h.
13			4	N37P16012B	Screw fastening side frame to end frame, 10-32, 3/4 in. r.h.
14	1	1	1	6710708	Spacer for upper series coil lead
15	1	1	1	6710707	Spacer for lower series coil lead
	2	2	2	N26P23020B	Bolt fastening spacer to base, 5/16 in. -18, 1 1/4 in. hex. h sl
16	4	4	4	1444467	Punched copper tube cable terminal, large, except 17LC24A2
16	2			1444467	Punched copper tube cable terminal, large, for 17LC24A2 only
17	1			2711922	Punched copper tube cable terminal, small, for 17LC24A2 only
18	2	2	2	N22P29032B	Bolt fastening terminal and series coil lead in position, 1/2 in. - 13, 2 in. hex. h.
19	1	1		3865522G1	Movable cores with adjusting screw
20			1	6710731	Movable cores with adjusting screws
21	1	1		1425527	Contact disk for movable core
		1	1	6724905	Compression spring for contact disk or operating bar
	1			2424595	Retaining collar for contact disk
		1		6712672	Retaining collar for contact disk
22	2	2		6711604	Support for contact plate
23	2	2		6710739	Connection block for support
	2	2		N37P21024B	Screw fastening support and connection block to base, 1/4 in. - 20, 1 1/2 in. r.h.
24	2	2		1457650	Contact plate
25	2	2		N37P21006B	Screw fastening contact plate to support, 1/4 in. -20, 3/8 in. r.h.
26	2	2		416575	Tinned copper terminal for connection block
27	2	2		N37P21008B	Screw fastening terminal to connection block, 1/4 in. -20, 1/2 in. r.h.

TYPE 17LC24A, -B AND -C RELAY

GEF-3048A

Ref. No.	No. Req. for Type 17LC24			Cat. No.	Description
	A	B	C		
28			1	6712662	Support for finger block and contact screw
29			2	N26P21016B	Bolt fastening support to base, 1/4 in. -20, 1 in. hex. h. sl.
30			1	6712663	Finger block
31			1	6712664	Bracket for stop screw
32			2	N44P14010B	Screw fastening finger block and bracket to support, 8-36, 5/8 in. fil. h.
33			1	N44P16012B	Stop screw for operating bar, 10-32, 3/4 in. fil. h.
34			1	6712670	Contact finger
35			1	6712665	Finger guide
36			2	N37P14006B	Screw fastening contact finger to finger block, 8-36, 3/8 in. r. h.
			1	410567	Terminal for finger block
37			1	N44P16006B	Screw fastening terminal to finger block, 10-32, 3/8 in. fil. h.
38			1	4702804	Contact screw with tip
			1	6712666	Insulation tube for contact tip
			2	2432292	Insulation washer for contact screw
			1	410567	Terminal for contact screw

NOTE: The following items are steel unless otherwise specified.

PLAIN WASHERS

Cat. No.	Description
166083	For No. 10 screw, .0625 in. thick
N402P9B	For No. 10 screw, .044 in. thick
N402P11B	For 1/4 in. screw
N402P12B	For 5/16 in. screw
84X301	For 1/2 in. screw

LOCK WASHERS

N405P38P	For No. 8 screw
N405P39P	For No. 10 screw
N405P41P	For 1/4 in. screw
N405P42P	For 5/16 in. screw
N405P45P	For 1/2 in. screw

NUTS

N210P16B	10-32 hex.
N203P21B	1/4 in. -20 hex. std.
N203P23B	5/16 in. -18 hex. std.

COTTER PINS

N503P1212B	1/8 in. by 3/4 in.
N503P1216B	1/8 in. by 1 in.

WHEN YOU NEED SERVICE

IF YOU NEED TO REPAIR, recondition, or rebuild any electric apparatus, a G-E service shop near you is available day and night, seven days a week, for work in the shops or on your premises. Latest factory methods and genuine G-E renewal parts are used to maintain the original performance of your G-E equipment. For full information about these services, contact the nearest service shop or sales office listed below:

APPARATUS SERVICE SHOPS

Appleton, Wisc. Midway Industrial Area,
County Trunk, "P"
Atlanta—Chamblee, Ga. 4639 Peachtree
Indus. Blvd.
Baltimore 30, Md. 920 E. Fort Ave.
Boston—Medford 55, Mass. Mystic Valley Pkwy.
Buffalo 11, N. Y. 318 Urban St.
Charleston 28, W. Va. 306 MacCorkle Ave., S.E.
Charlotte, N. C. 2328 Thrift Road
Chicago 32, Ill. 4360 W. 47th St.
Cincinnati 2, Ohio 444 W. Third St.
Cleveland 4, Ohio 4966 Woodland Ave.
Columbus 23, Ohio 2128 Eakin Rd.
Dallas 9, Texas 3202 Manor Way
Davenport—Bettendorf, Ia. 1039 State St.
Decatur, Ill. 2225 E. Logan St.
Denver 5, Colo. 3353 Larimer St.
Detroit 2, Mich. 5950 Third Ave.
Houston 20, Texas 5534 Harvey Wilson Drive
Indianapolis, Ind. 1740 W. Vermont St.
Johnstown, Pa. 841 Oak St.
Kansas City 8, Mo. 819 E. 19th St.
Los Angeles 1, Calif. 6900 Stanford Ave.
Louisville, Ky. 2014 New Main St.
Midland, Tex. 3404 Bankhead Hwy.
Milwaukee 3, Wisc. 940 W. St. Paul Ave.
Minneapolis 12, Minn. 2025 49th Ave., N.
New York 14, N. Y. 416 W. 13th St.
Philadelphia 23, Pa. 1040 E. Erie Ave.
Pittsburgh 6, Pa. 6519 Penn Ave.
Portland 18, Oregon 2727 N.W. 29th Ave.
Richmond 24, Va. 1403 Ingram Ave.
St. Louis 10, Mo. 1115 East Road
Salt Lake City 4, Utah 301 S. Seventh West St.
San Francisco 3, Calif. 1098 Harrison St.
Seattle 4, Wash. 3422 First Ave., S.
Spokane 3, Wash. S. 155 Sherman St.
Toledo 4, Ohio 1 So. St. Clair St.
York, Pa. 54 N. Harrison St.
Youngstown 5, Ohio 272 E. Indianola Ave.

APPARATUS SALES OFFICES

Abilene, Texas 442 Cedar St.
Akron 8, Ohio 335 S. Main St.
Albany 7, N. Y. 90 State St.
Albuquerque, N. Mex. 323 Third St., S.W.
Alexandria, La. 720 Murray St.
Allentown, Pa. 1132 Hamilton St.
Amarillo, Texas 402 Amarillo Bldg.
Appleton, Wisc. 531 W. College Ave.
Atlanta 3, Ga. 1860 Peachtree Rd., N.W.
Augusta, Ga. 423 Masonic Bldg.
Augusta, Me. 15 Grove St.
Baltimore 1, Md. 111 Park Ave.
Bangor, Maine 77 Central St.
Baton Rouge 6, La. 3170 Florida B'vd.
Battle Creek, Mich. 25 W. Michigan Ave.
Beaumont, Texas 1385 Calder Ave.
Billings, Mont. Rm. 816, 303 No. Broadway
Binghamton, N. Y. 19 Chenango St.
Birmingham 3, Ala. 1804 Seventh Ave., N.
Bismarck, N. Dak. 418 Rosser Ave.
Bluefield, W. Va. P.O. Box 447, Appalachian Bldg.
Boise, Idaho 1524 Idaho St.
Boston 1, Mass. 140 Federal St.
Buffalo 3, N. Y. 535 Washington St.
Butte, Mont. P.O. Box 836, 103 N. Wyoming St.
Canton 2, Ohio 700 Tuscarawas St., W.
Cedar Rapids, Iowa 210 Second St., S.E.
Charleston 28, W. Va. 306 MacCorkle Ave., S.E.
Charlotte 1, N. C. 112 S. Tryon St.
Chattanooga 2, Tenn. 832 Georgia Ave.
Chicago 80, Ill. P.O. Box 5970A, 840 S. Canal St.
Cincinnati 2, Ohio 215 W. Third St.
Cleveland 4, Ohio 4966 Woodland Ave.
Columbia 15, S.C. P.O. Box 1434, 1420 Lady St.
Columbus 15, Ohio 40 S. Third St.
Corpus Christi, Texas 205 N. Chaparral
Dallas 2, Texas 1801 N. Lamar St.
Davenport—Bettendorf, Ia. 1039 State St.
Dayton 2, Ohio 11 W. Monument Bldg.



For service outside the United States, Canada, and Hawaii, consult the nearest office of the International General Electric Company.

Denver 2, Colo. 650 Seventeenth St.
Des Moines 9, Iowa 505 W. Fifth Ave.
Detroit 2, Mich. 700 Antoinette St.
Duluth 2, Minn. 14 W. Superior St.
Elmira, N. Y. Main and Woodlawn Aves.
El Paso, Texas 215 No. Stanton
Erie, Pa. 1001 State St.
Eugene, Ore. 610 High St.
Evansville 19, Ind. 123 N.W. Fourth St.
Fairmont, W. Va. 310 Jacobs Bldg.,
P.O. Box 1626
Fergus Falls, Minn. 108 N. Court Ave. P.O. Box 197
Flint 3, Mich. 653 S. Saginaw St.
Fort Wayne 6, Ind. 3606 So. Calhoun
Fort Worth 2, Texas 408 W. Seventh St.
Fresno 1, Calif. 407 Patterson Bldg.
Tulare and Fulton St.
Grand Rapids 2, Mich. 148 Monroe Ave., N.W.
Greensboro, N. C. 301 S. Elm St.
Greenville, S. C. 108 W. Washington St.
Gulfport, Miss. 207 Jo-Fran Bldg.
Hagerstown, Md. Professional Arts Bldg.
Hartford 3, Conn. 410 Asylum St.
Houston 1, Texas 1312 Live Oak St.
Indianapolis 4, Ind. 110 N. Illinois St.
Jackson, Mich. 120 W. Michigan Ave.
Jackson 1, Miss. 203 W. Capitol St.
Jacksonville 2, Fla. 700 E. Union St.
Jamestown, N. Y. P.O. Box 548, 2 Second St.
Johnson City, Tenn. 321-323 W. Walnut St.
Johnstown, Pa. 841 Oak St.
Joplin, Mo. P.O. Box 948, 220 1/2 W. Fourth St.
Kalamazoo 3, Mich. 112 Parkway Ave.
Kansas City 6, Mo. 106 W. Fourteenth St.
Knoxville 08, Tenn. 602 S. Gay St.
Lansing 8, Mich. 306 Michigan National Tower
Lexington, Ky. First National Bank Bldg.
Lincoln 8, Nebr. Sharpe Bldg., 206 S. 13th St.
Little Rock, Ark. 103 W. Capitol Ave.
Los Angeles 54, Calif. 212 N. Vignes St.
Louisville 2, Ky. 455 S. Fourth St.
Macon, Ga. 682 Cherry St.
Madison 3, Wisc. 16 N. Carroll St.
Manchester, N. H. 875 Elm St.
Medford, Ore. P.O. Box 1349, 205 W. Main St.
Memphis 3, Tenn. 8 N. Third St.
Miami 32, Fla. 25 S.E. Second Ave.
Milwaukee 3, Wisc. 940 W. St. Paul Ave.
Minneapolis 3, Minn. 12 S. Sixth St.
Mobile 13, Ala. 54 St. Joseph St.
Nashville 3, Tenn. 234 Third Ave., N.
Newark 2, N. J. 744 Broad St.
New Haven 6, Conn. 129 Church St.
New Orleans 12, La. 837 Gravier St.
New York 22, N. Y. 570 Lexington Ave.
Niagara Falls, N. Y. 253 Second St.

Norfolk 10, Va. 229 W. Bute St.
Oakland 12, Calif. 409 Thirteenth St.
Oklahoma City 2, Okla. 119 N. Robinson St.
Omaha 2, Nebr. 409 S. Seventeenth St.
Pasco, Wash. 421 W. Clark St.
Peoria 2, Ill. 309 Jefferson Bldg.
Philadelphia 2, Pa. 1405 Locust St.
Phoenix, Ariz. P.O. Box 4037, 303 Luhrs Tower
Pittsburgh 22, Pa. The Oliver Bldg., Mellon Sq.
Portland 7, Ore. 920 S.W. Sixth Ave.
Providence 3, R. I. Industrial Trust Bldg.
Raleigh, N. C. 336 Fayetteville St.
Reading, Pa. 31 N. Sixth St.
Richmond 17, Va. 700 E. Franklin St.
Riverside, Calif. 3570 Ninth St.
Roanoke 16, Va. 920-924 S. Jefferson St.
Rochester 4, N. Y. 89 E. Ave.
Rockford, Ill. 110 S. First St.
Rutland, Vt. 38 1/2 Center St.
Sacramento 14, Calif. 626 Forum Bldg.
Saginaw, Mich. Second National Bank Bldg.
St. Louis 1, Mo. 818 Olive St.
Salt Lake City 9, Utah 200 S. Main St.
San Antonio 5, Texas 434 So. Main Ave.
San Diego 1, Calif. 1240 Seventh Ave.
San Francisco 6, Calif. 235 Montgomery St.
San Jose 10, Calif. 460 Park Ave.
Savannah, Ga. 4 E. Bryan St.
Seattle 4, Wash. 710 Second Ave.
Shreveport, La. 910 Shelby Bldg.
Sioux City 13, Iowa. 572 Orpheum Electric Bldg.
Sioux Falls, S. D. 306 South Phillips Ave.
South Bend 1, Ind. 112 W. Jefferson Blvd.
Spokane 4, Wash. S. 162 Post St.
Springfield, Ill. 607 E. Adams St.
Springfield 3, Mass. 1387 Main St.
Stockton, Calif. 11 So. San Joaquin St.
Syracuse 2, N. Y. 113 S. Salina St.
Tacoma 1, Wash. 1202 Washington Bldg.
Tampa 6, Fla. 1206 North A St.
Toledo 4, Ohio 420 Madison Ave.
Trenton 8, N. J. 214 E. Hanover St.
Tucson, Ariz. P.O. Box 710, 650 N. Sixth Ave.
Tulsa 3, Okla. 320 S. Boston Ave.
Utica 2, N. Y. 258 Genesee St.
Washington 5, D.C. 777-14th St., N.W.
Waterbury 89, Conn. 111 W. Main St.
Waterloo, Iowa 206 W. 4th St.
Wenatchee, Wash. 328 N. Wenatchee Ave.
Wheeling, W. Va. 40 Fourteenth St.
Wichita 2, Kan. 200 E. First St.
Williamston, N. C. 115 E. Main St.
Worcester 5, Mass. 288 Grove St.
York, Pa. 56 N. Harrison St.
Youngstown 5, Ohio 272 E. Indianola Ave.

Hawaii: American Factors, Ltd., P. O. Box 3230, Honolulu 1 Canada: Canadian General Electric Company, Ltd., Toronto

LOCOMOTIVE AND CAR EQUIPMENT DEPARTMENT, GENERAL ELECTRIC COMPANY, ERIE, PA.

RENEWAL PARTS



TYPE 17HE8 SWITCHES

Forms A1, B1, C1, D1, E1, F1, H1, J1, K1, L1, M1, N1, R1, S1, T1, V1, W1, and Y1

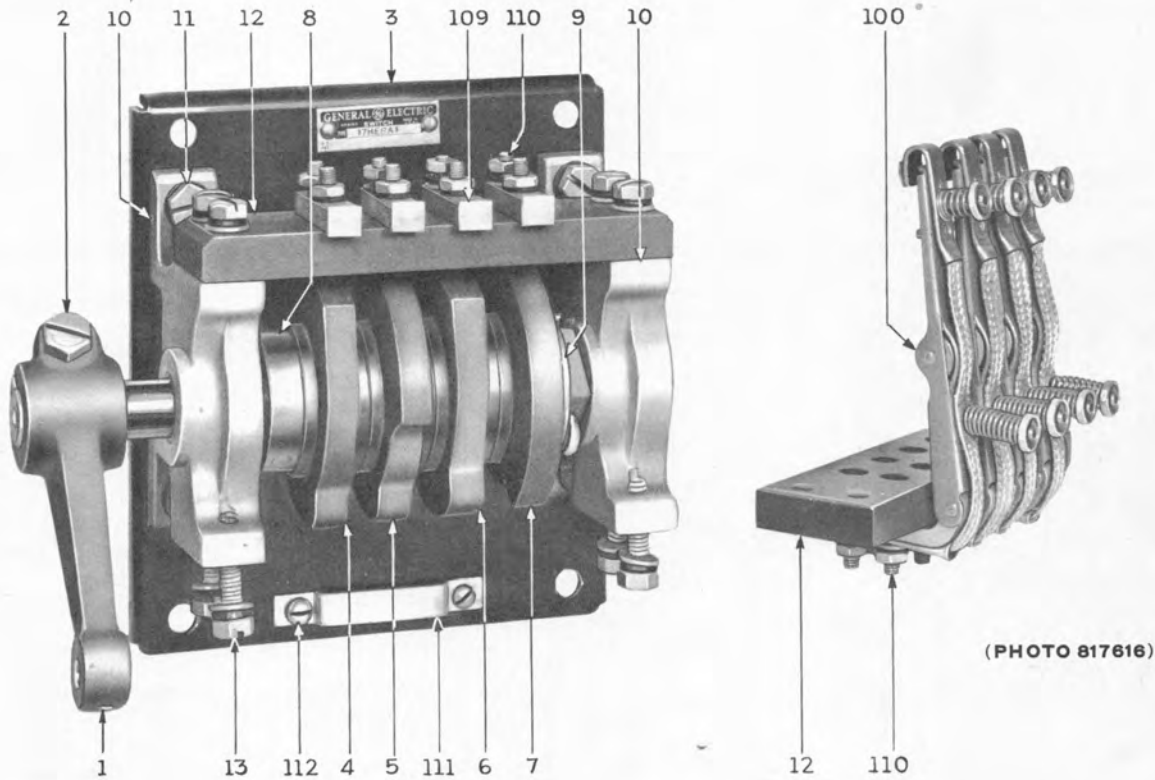

(PHOTO 817616)

Type 17HE8A switch

Ref. No.	Number Required for Type 17HE8-																			Cat. No.	Description
	A1	B1	C1	D1	E1	F1	H1	J1	K1	L1	M1	N1	R1	S1	T1	V1	W1	Y1			
1	1	1	1	1	1		1	1	1		1	1	1	1	1	1	1	1	1	6721828	Operating lever
1						1				1										6721828AA	Operating lever
	1	1	1	1	1	1	1	1	1	1	1	1	1	1	1	1	1	1	1	246750	Key for operating lever and camshaft
2	1	1	1	1	1	1	1	1	1	1	1	1	1	1	1	1	1	1	1	144048	Clamping screw for operating lever (5/16 in.-18)
3	1	1	1	1	1	1	1	1	1	1	1	1	1	1	1	1	1	1	1	6711446	Base

When ordering renewal parts, give quantity, catalog number, description of each item required, and complete nameplate reading.



TYPE 17HE8 SWITCHES

CAMSHAFTS AND CAMS

Type 17HE8-	Camshaft with collars and collar	Ref. No. 4		Ref. No. 5		Ref. No. 6		Ref. No. 7	
		+ Cam, 1st		+ Cam, 2nd		+ Cam, 3rd		+ Cam, 4th	
	Cat. No.	Cat. No.	Stamped	Cat. No.	Stamped	Cat. No.	Stamped	Cat. No.	Stamped
A1	4728971G1	111X30	4749000JB1	111X31	4749000JC1	111X34	4749000JD1	111X37	4749000JE1
B1	4728971G2	110X3	4749000	111X32	4749000HR2	111X35	4749000HR1	111X35	4749000HR1
C1	4728628G1	110X3	4749000	111X33	4749000CZ3	111X36	4749000HX1	111X38	4749000HY1
D1	4749530G1	112X90	4749000HZ1	112X92	4749000JA1	110X3	4749000	110X3	4749000
E1	4749530G3	112X91	4749000JM1	112X93	4749000JN1	112X94	4749000JP1	112X95	4749000JR1
F1	4728628G2	110X3	4749000	122X3	4749000DB1	128X88	4749000LA1	128X90	4749000LB1
H1	4728971G4	110X3	4749000	11X32	4749000HR2	111X35	4749000HR1	111X35	4749000HR1
J1	4749530G5	112X90	4749000HZ1	112X92	4749000JA1	128X89	4749000LF1	128X89	4749000LF1
K1	4728628G3	144X13	4749000ME1	111X33	4749000CZ3	11X36	4749000HX1	111X38	4749000HY1
L1	4728628G4	129X99	4749000FC6	122X3	4749000DB1	128X88	4749000LA1	128X90	4749000LB1
M1	6735501G1	110X3	4749000	139X61	4749000NG1	139X61	4749000NG1	128X4	4749000LD1
N1	6735501G2	110X3	4749000	110X3	4749000	110X3	4749000	128X4	4749000LD1
R1	6735524G1	110X3	4749000	138X72	4749000JR2	138X73	4749000NM1	138X74	4749000NN1
S1	6735524G2	128X4	4749000LD1	138X72	4749000JR2	138X73	4749000NM1	138X74	4749000NN1
T1	6735711G1	144X14	4749000NV1	111X32	4749000HR2	111X35	4749000HR1	111X35	4749000HR1
V1	6735501G3	128X4	4749000LD1	122X4	4749000DA1	110X3	4749000	110X3	4749000
W1	4749530G6	112X90	4749000HZ1	112X92	4749000JA1	144X15	4749000CAZ1	110X3	4749000
Y1	6735524G3	128X4	4749000LD1	130X7	4749000FS5	138X73	4749000NM1	138X74	4749000NN1

+ Location of cams determined by counting from lever end

Ref. No.	Number Required for Type 17HE8-																		Cat. No.	Description
	A1	B1	C1	D1	E1	F1	H1	J1	K1	L1	M1	N1	R1	S1	T1	V1	W1	Y1		
8	1	1	1	1	1	1		1	1	1	1	1	1	1	1	1	1	1	4728972P1	Camshaft
	1	1	1	1	1	1	1	1	1	1	1	1	1	1	1	1	1	1	4728972P5	Camshaft
	1	1	1	1	1	1	1	1	1	1	1	1	1	1	1	1	1	1	1416798	Collar for camshaft
9																			488105	Pin for collar and camshaft
	1	1	1	1	1	1	1	1	1	1	1	1	1	1	1	1	1	1	4709521	Retaining washer for cams
10	2	2	2	2	2	2	2	2	2	2	2	2	2	2	2	2	2	2	2743760G4	Bearing block with bushing, for camshaft
	2	2	2	2	2	2	2	2	2	2	2	2	2	2	2	2	2	2	350X9	Bushing for bearing block
11	4	4	4	4	4	4	4	4	4	4	4	4	4	4	4	4	4	4	17376	Screw fastening bearing block to base (5/16 in.-18)
12	2	2	2	2	2	2	2	2	2	2	2	2	2	2	2	2	2	2	6711447	Supporting block for contact fingers or stationary contacts
13	8	8	8	8	8	8	8	8	8	8	8	8	8	8	8	8	8	8	46X777	Screw fastening supporting block to bearing block (1/4 in.-20)
100	4	3	3	2	4	3	3	4	4	4	3	1	3	4	4	2	3	4	4734382G1	Contact finger
101	4	3	3	2	4	3	3	4	4	4	3	1	3	4	4	2	3	4	6700549	Contact tip with flexible shunt
102	4	3	3	2	4	3	3	4	4	4	3	1	3	4	4	2	3	4	4734947	Compression spring for contact finger
103	4	3	3	2	4	3	3	4	4	4	3	1	3	4	4	2	3	4	4731905	Compression spring for contact tip
104	4	3	3	2	4	3	3	4	4	4	3	1	3	4	4	2	3	4	6700546	Spring post for Cat. 4734947
105	4	3	3	2	4	3	3	4	4	4	3	1	3	4	4	2	3	4	6700547	Spring post for Cat. 4731905
106	4	3	3	2	4	3	3	4	4	4	3	1	3	4	4	2	3	4	80X30	Washer between compression spring and contact tip
	A1	B1	C1	D1	E1	F1	H1	J1	K1	L1	M1	N1	R1	S1	T1	V1	W1	Y1		

TYPE 17HE8 SWITCHES

GEF-3072C

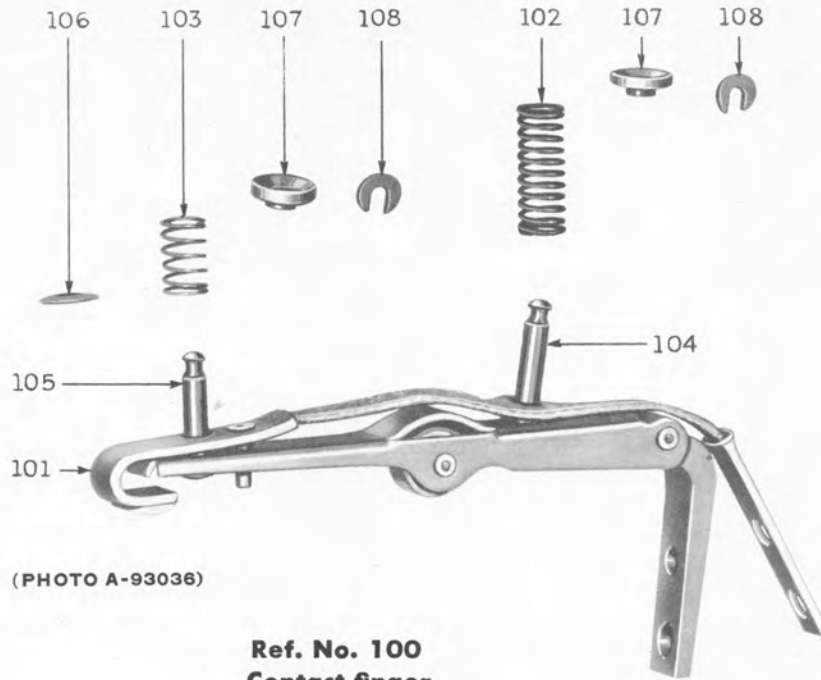

(PHOTO A-93036)

Ref. No. 100
Contact finger

Ref. No.	Number Required for Type 17HE8-																		Cat. No.	Description
	A1	B1	C1	D1	E1	F1	H1	J1	K1	L1	M1	N1	R1	S1	T1	V1	W1	Y1		
107	8	6	6	4	8	6	6	8	8	8	6	2	6	8	8	4	6	8	6700539	Spring seat for compression spring
108	8	6	6	4	8	6	6	8	8	8	6	2	6	8	8	4	6	8	6700545	Retainer for spring seat
109	4	3	3	2	4	3	3	4	4	4	3	1	3	4	4	2	3	4	4709938	Stationary contact
110	16	12	12	8	16	12	12	16	16	16	12	4	12	16	16	8	12	16	20X558	Screw fastening contact finger or stationary contact to supporting block (10-32)
	2													2	1			2	4704700	Connection strip for contact fingers
						1				1									6711448	Bracket with stud, for cover, operating lever end
						1				1									6711449	Bracket with stud, for cover, opposite operating lever end
						1				1									4749045G5	Cover
						2				2									59X241	Wing nut for cover
111	1	1	1	1	1	1	1	1	1	1	1	1	1	1	1	1	1	1	1456711	Cable cleat
	1	1	1	1	1	1	1	1	1	1	1	1	1	1	1	1	1	1	4749044P2	Insulation shield for cable cleat
112	2	2	2	2	2	2	2	2	2	2	2	2	2	2	2	2	2	2	206868	Screw fastening cable cleat to base (8-36)
	A1	B1	C1	D1	E1	F1	H1	J1	K1	L1	M1	N1	R1	S1	T1	V1	W1	Y1		

TYPE 17HE8 SWITCHES

PLAIN WASHERS

Cat. No.	Description
150279	For No. 10 screw
143974	For 1/4 in. screw

NUTS

145996	10-32, hex. std
126869	5/16 in.-18, hex. std

LOCK WASHERS

Cat. No.	Description
54X473	For No. 8 screw
54X441	For No. 10 screw
30X562	For 1/4 in. screw
6X814	For 5/16 in. screw

COTTER PIN

139648	3/16 in. by 1 1/4 in.
--------	-----------------------

LOCOMOTIVE AND CAR EQUIPMENT DEPARTMENT

GENERAL  ELECTRIC

ERIE, PA.

parts

TYPE 17CM12BD, -BE, -BH, AND -BS CONTACTORS

SEE OBSOLESCENCE LETTER 78-1
(NEXT PAGE)

NOTE:-The last number in the nameplate rating is the coil number.

Example:-Type 17CM12BD4 indicates that operating coil Cat.No. 2738585 is required.

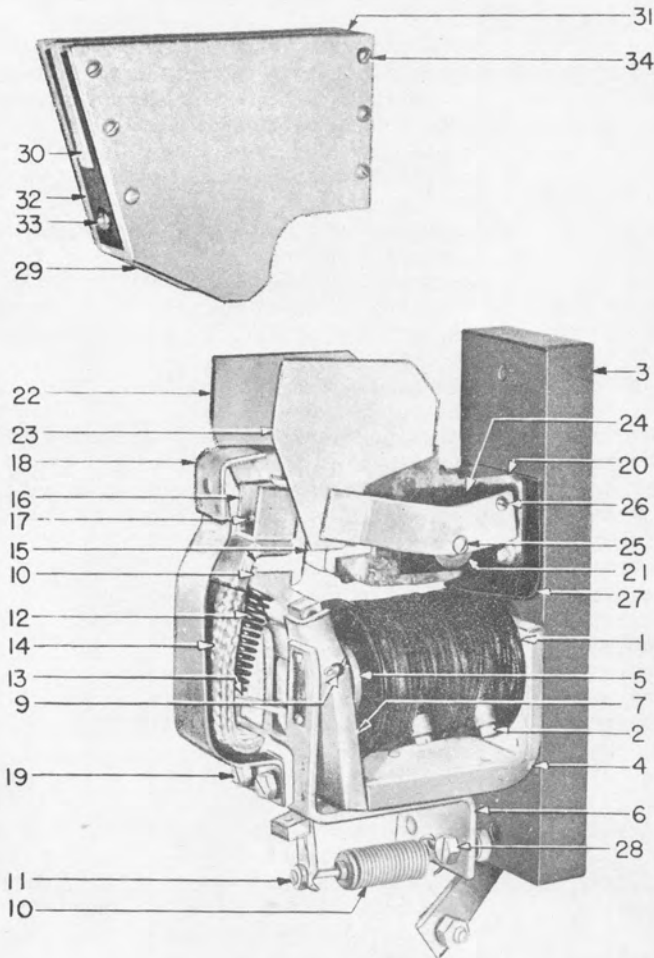

Type 17CM12BE2 contactor

Ref.No. 1 - OPERATING COILS - (1 Required)

Coil No.	Cat.No.	Coil No.	Cat.No.
2	#2738575	20	#4739235
4	#2738585	23	4739326
6	#2738604	30	4739369
11	#2738679	33	4739368

‡ See table on pages 3 and 4 for new design operating coils.

When ordering renewal parts, give quantity, catalog number, description of each item required, and complete nameplate reading.
Data subject to change without notice.

*Supersedes GEF-3120B

TYPE 17CM12 CONTACTORS

Ref. No.	No. Req. for Type 17CM12-				Cat. No.	Description
	BD	BE	BH	BS		
	1	1	1	1	4710413	Rubber washer for operating coil
	2	2	2	2	207248	Screw fastening operating coil to magnet frame (8-36)
2	2	2	2	2	4731833P4	Screw fastening terminal to operating coil (10-32)
3	1				4710370	Supporting block
3		1	1	1	4711745	Supporting block
	1		1		6713391	Insulation shield for supporting block
	2		2		205064	Wood screw fastening shield to block
4	1	1	1	1	4768834	Magnet frame
	2	2	2	2	187184	Screw fastening magnet frame to block (5/16 in.-18)
	1	1	1	1	6714556	Insulation shield between magnet frame and supporting block
	1		1		6703437	Insulation shield between magnet frame and operating coil
	2		2		91X733	Screw fastening shield to magnet frame
5	1	1	1	1	4710372	Magnet core for operating coil
	1	1	1	1	143997	Screw fastening core to magnet frame (3/8 in.-16)
6	1	1	1	1	4737935AV	Armature stop
	2	2	2	2	46X777	Screw fastening armature stop to magnet frame (1/4 in.-20)
	1		1	1	144X10	Armature with contact lever, stop arms, and spring bracket
		1			144X11	Armature with contact lever, stop arms, and spring bracket
7	1		1	1	2738986G3	Armature with stop arms and spring bracket
7		1			2738986G1	Armature with stop arms and spring bracket
8	1	1	1	1	6713313	Contact lever with link
9	1	1	1	1	8800422	Hinge pin for contact lever link
10	1	1	1	1	4735918	Tension spring with plug, for armature
11	1	1	1	1	6700342	Adjusting screw for tension spring (10-32)
	1		1	1	6702487	Counterweight for armature
	1		1	1	17366	Screw fastening counterweight to armature (5/16 in.-18)
12	1	1	1	1	6724998	Compression spring for contact lever
13	1	1	1	1	4710379	Spring seat for compression spring
	4	4	4	4	4710450	Shim for spring seat
14	1				4767443	Flexible shunt for contact lever
14		1	1	1	4731183	Flexible shunt for contact lever
15	2	2	2	2	6713304	Contact tip
16	1	1	1	1	6713310	Arcing horn for movable contact tip
	1	1	1	1	6713309	Arcing horn for stationary contact tip
17	2	2	2	2	91X103	Screw fastening contact tip in position (5/16 in.-18)
18	1	1	1	1	4715961	Arcing horn with spring
19	2	2	2	2	126872	Screw fastening arcing horn and shunt to armature stop (5/16 in.-18)
20	1				127X86	Stationary contact support with blowout coil, insulated core, and pole pieces
20		1	1	1	130X17	Stationary contact support with blowout coil, insulated core, and pole pieces
	1	1	1	1	4750508	Insulated core for blowout coil
	1	1	1	1	4710381	Core for blowout coil
	1	1	1	1	4715482	Insulation tube for core
21	2	2	2	2	4715483	Insulation flange for core
22	1	1	1	1	6725027G2	Pole piece for blowout coil, left-hand facing front of contactor
23	1	1	1	1	6725027G1	Pole piece for blowout coil, right-hand facing front of contactor
24	2	2	2	2	4710809	Insulation between pole piece and blowout coil
25	2	2	2	2	105136	Screw fastening pole piece to core (10-32)
26	1	1	1	1	54X992	Screw fastening pole pieces to stationary contact support (10-32)
	1	1	1	1	4710386	Insulation tube for Cat. 54X992
	2	2	2	2	4710385	Spacer between pole piece and stationary contact
27	1				4710409	Insulation shield between stationary contact support and supporting block
27		1	1	1	6712046	Insulation shield between stationary contact support and supporting block

GENERAL ELECTRIC

GENERAL ELECTRIC COMPANY, 2901 EAST LAKE ROAD, ERIE, PENNSYLVANIA 16531
Phone (814) 455-5466

TRANSPORTATION
SYSTEMS
BUSINESS
DIVISION

OBSOLESCENCE LETTER 78-1

17CM12 Contactors
Obsolescence

The 17CM12 line of contactors has been obsolete for 30 years but parts support has been continued up to the present. It is now necessary to discontinue our parts support for these devices. All parts used specifically in their manufacture (except contact tips) have been declared obsolete.

The parts you have specified can no longer be supplied by General Electric Company and it therefore will be necessary for you to install a new contactor of current design. The attached cross reference should permit you to select the proper replacement contactor for your equipment. Please notify us if your contactor is not included in this cross reference and we will provide you with a recommended device. The complete model number of your device will be required.

We regret the necessity of this action, but feel that in providing you with the latest devices available, your parts service will be enhanced both from the standpoint of price and delivery.



Attach. (2)

17CM12 CONTACTOR SUPERSEDURE LIST

17CM12B2	USE	17CM53A9
B3		A12
B4		A6
B6		A5
B16		A9
B18		A12
B19		A2
B23		A9
B34		A6
H5		A2
H9		A2
H10		A2
H15		A11
H41		A9
J2		E10A + 482A327G1 Adapter
J7		E10A + 482A327G1 Adapter
J15		E11A + 482A327G1 Adapter
J17		E10A + 482A327G1 Adapter
J29		E11A + 482A327G1 Adapter
J31		E10A + 482A327G1 Adapter
L15		B11 + 482A327G1 Adapter
L20		B7 + 482A327G1 Adapter
L23		B9 + 482A327G1 Adapter
L30		B7 + 482A327G1 Adapter
L34		B6 + 482A327G1 Adapter
R6		K5
R23		K9
R33		K3
S2		A9
S4		A6
S6		A5
S15		A11
S17		A10
S20		A7
S23		A9
S30		A7
S33		A3
Y17		A10
AC2		B9 + 482A327G1 Adapter
AC15		B11 + 482A327G1 Adapter
AD6		A5
AG10		A2
AG15		A11
AG29		A11
AL4		B6 + 482A327G1 Adapter
AL23		B9 + 482A327G1 Adapter
AL30		B7 + 482A327G1 Adapter
AL33		B3 + 482A327G1 Adapter
AL34		B6 + 482A327G1 Adapter

17CM12 CONTACTOR SUPERSEDURE LIST

<u>17CM12AM2</u>	<u>USE</u>	<u>17CM53K9</u>
AM15		K11
AM20		K7
AM23		K9
AM30		K7
AR30		B7
BA19		A2
BB18		A12
BD6		K5
BD11		K3
BE2		A9
BE20		A7
BE23		A9
BE30		A7
BE34		A6
BH4		K6
BH11		K3
BH17		K10
BK2		A9
BK19		A2
BS33		K3
BU2		A9
CC31		B10
CC34		B7

TYPE 17CM12 CONTACTORS

Ref. No.	No. Req. for Type 17CM12-				Cat.No.	Description
	BD	BE	BH	BS		
28	2	2	2	2	187184	Screw fastening stationary contact support to supporting block (5/16 in.-18)
	2	2	2	2	143937	Screw fastening terminal to blowout coil lead or armature stop (3/8 in.-16)
	1	1	1	1	15988	Wood screw fastening blowout coil lead to supporting block
	1		1		4745353G2	Arc chute
29		1			4745353G3	Arc chute
	2		2		6713314	Side plate for arc chute
29		2		2	6713411	Side plate for arc chute
30	1		1		6713315	Arc suppressor plate
30		1		1	4715965	Arc suppressor plate
31	1		1		127X87	Short spacing block with latch pin
31		1		1	4756737	Short spacing block with latch pin
32	1		1		127X88	Long spacing block with latch
32		1		1	4756738	Long spacing block with latch screw
33		1		1	2710147	Latch screw for long spacing block (10-32)
34	4	6	4	6	198709	Screw fastening arc chute together (10-32)
	BD	BE	BH	BS		

PLAIN WASHERS

Cat.No.	Description
155830	For No. 8 screw
150279	For No. 10 screw
143974	For 1/4 in. screw
145598	For 5/16 in. screw, 5/8 in. O.D.
147674	For 5/16 in. screw, 7/8 in. O.D.
141259	For 3/8 in. screw

LOCK WASHERS

Cat.No.	Description
54X473	For No. 8 screw
54X441	For No. 10 screw
71X749	For No. 10 screw, Shakeproof
30X562	For 1/4 in. screw
6X814	For 5/16 in. screw
6X815	For 3/8 in. screw

NUTS

145996	10-32, hex. std
151175	10-32, hex. std, brass
141255	3/8 in.-16, hex. std

COTTER PIN

139048	5/64 in. by 3/8 in.
--------	---------------------

Two designs of operating coils have been furnished for the Type 17CM12 Contactor. The first design of operating coil Fig. 1 has round spool flanges at both ends, the second design Fig. 2 has one round and one offset spool flange which provides for fastening to the contactor frame by means of two 8-36, 1/2 in. r.h. screws Cat.No. 207248. This design prevents breaking connections by the turning of the operating coil.

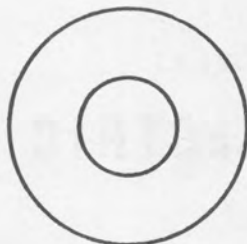

Fig. 1

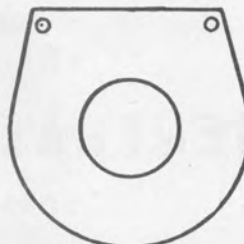

Fig. 2

TYPE 17CM12 CONTACTORS

Operating Coils listed in this table are interchangeable, except that the contactor frame must be machined in accordance with Fig. 3 before the operating coils of the second design can be applied. The rubber washers used with operating coils of the first design Fig. 1 are not required for the second design Fig. 2.

Operating Coil	Cat.No.
Fig. 1	Fig. 2
Design	Design
2738575	4739326
2738585	4739366
2738604	4739367
2738679	4739368
4739235	4739369

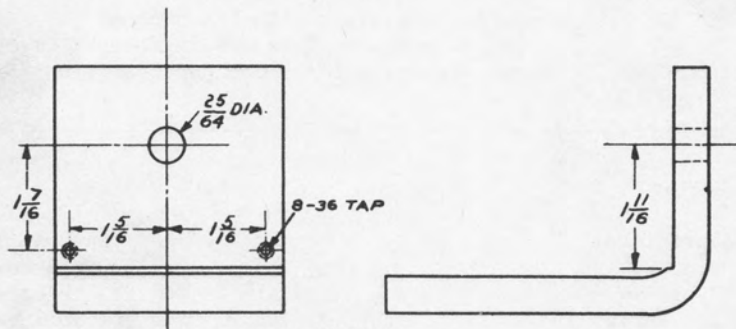

Fig. 3

- 1 Remove partial radius in bend of frame as shown.
- 2 Drill and tap frame locating two tapped holes from the center of the present 25/64 in. diam hole in frame.
- 3 Place new design coil retainer furnished with coil between core body and coil spool with long end inside coil and short end under core head.

APPARATUS DEPARTMENT

GENERAL  ELECTRIC

SCHENECTADY, N. Y.

parts

TYPE 17EW101R2 RESISTOR

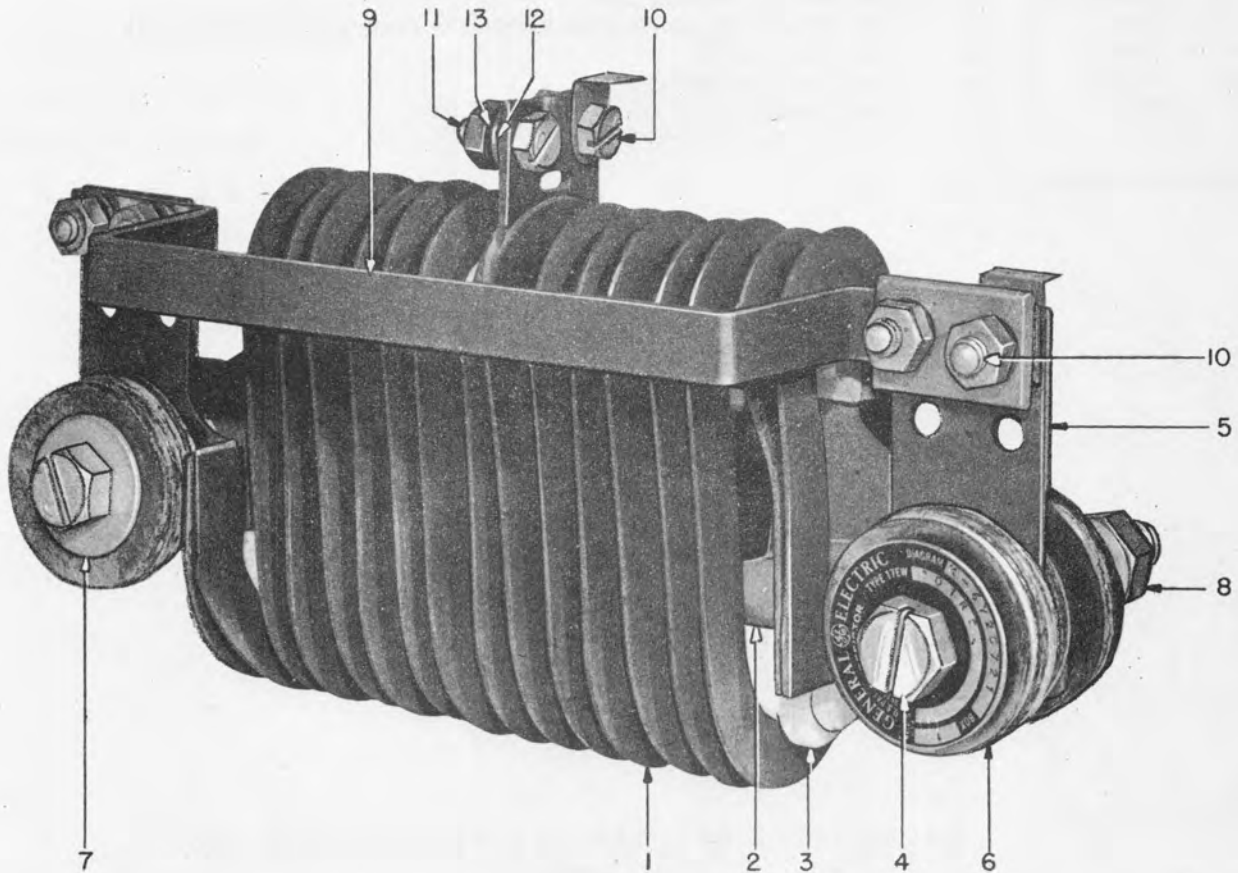

Note:- When ordering resistor unit Reference Number 1 customer should refer to Catalog Number stamped on resistor unit terminal or to index sheets in Renewal Parts Catalog.

Ref. No.	Cat. No.	No. Required	Description
2	21D497	1	Support for resistor unit
3	11D864	Δ	Insulator for resistor unit (6 grooves)
3	12D525	Δ	Insulator for resistor unit (7 grooves)
3	11D836	Δ	Insulator for resistor unit (9 grooves)
3	12D535	Δ	Insulator for resistor unit (11 grooves)
4	84X305	2	Screw fastening resistor unit in position, 1/2 in.-13
	6702142	2	Insulation sleeve for screw
	6710506	2	Spacer for screw

Δ Quantity variable

When ordering renewal parts, give quantity, catalog number, description of each item required, and complete nameplate reading. Data subject to change without notice.

TYPE 17EW101R2 RESISTOR

Ref. No.	Cat. No.	No. Required	Description
5	11D779	2	Supporting plate for terminal
6	11D813	4	Mica washer (5/8 in. thick)
6	11D814	2	Mica washer (1/8 in. thick)
	11D815	8	Steel washer (1 1/2 in. O.D.)
7	1440868	4	Steel washer (1 3/8 in. O.D.)
	84X301	4	Steel washer (1 in. O.D.)
8	146149	4	Nut, 1/2 in.-13
	10X903	4	Lock washer, 1/2 in.
9	2743997P3	Δ	Bus bar for resistor unit
10	17376	Δ	Screw fastening bus bar or terminal to resistor unit, 5/16 in.-18
11	126869	Δ	Nut, 5/16 in.-18
12	145598	Δ	Plain washer, 5/16 in.
13	6X814	Δ	Lock washer, 5/16 in.

Δ Quantity variable

LOCOMOTIVE AND CAR EQUIPMENT DIVISIONS

GENERAL  ELECTRIC

ERIE, PA.

RENEWAL PARTS

TYPE 17CM15 CONTACTORS

Forms AA, AT, BA, BB, BC, BD, CC, EE, FF, NN, RR, SS, TT, VV, and YY

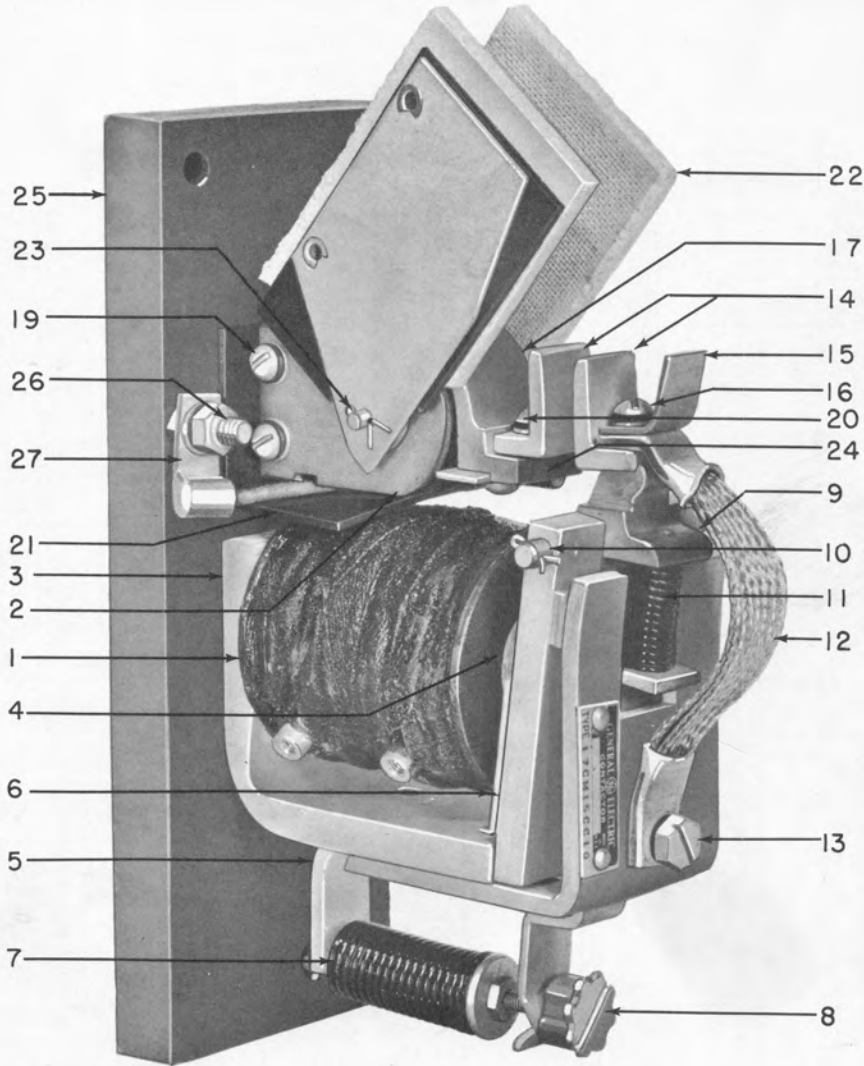

(PHOTO 812578)

Type 17CM15CC38 contactor

(Reference numbers are indicated in listings beginning on page 2)

When ordering renewal parts, give quantity, catalog number, description of each item required, and complete nameplate reading.



TYPE 17CM15 CONTACTORS

NOTE:- The last number in the nameplate rating is the coil number.

Example:- Type 17CM15AA5 indicates that operating coil Cat.No. 2738516 and blowout coil Cat.No. 4756444 are required.

Coil No.	Ref.No. 1	Ref.No. 2	Coil No.	Ref.No. 1	Ref.No. 2	Coil No.	Ref.No. 1	Ref.No. 2
	Operating Coil	Blowout Coil		Operating Coil	Blowout Coil		Operating Coil	Blowout Coil
	Cat.No.	Cat.No.		Cat.No.	Cat.No.		Cat.No.	Cat.No.
1	‡2738570	2738538	37	2738184	2738548	78	4739318	2738538
4	‡2738573	2738563	38	2738184	2738563	79	4739380	2738538
5	‡2738516	+4756444	40	4739172	-----	82	4739477	4739111
6	‡2738570	+4757835	41	‡2738606	2738563	83	4739393	+4756444
7	‡2738570	2738563	42	‡2738570	2738765	84	4739472	+4756444
8	‡2738567	2738538	43	‡2738573	2738538	88	8827030	+4756444
10	‡2738516	2738563	45	‡2738544	2738563	89	8827030	2738563
11	‡2738101	+4756444	51	2738184	4739111	90	8827030	2738538
12	2738184	+4756444	52	‡2738434	2738563	91	8827030	2738548
13	‡2738613	+4756444	57	4739357	+4756444	92	4739379	2738563
14	‡2738603	2738538	58	4739333	2738538	95	4739458	2738563
16	‡2738567	+4756444	59	4739318	4739311	96	4739458	4739111
19	‡2738649	2738563	60	4739370	+4756444	97	2738769	2738538
20	‡2738649	+4756444	61	4739370	2738538	100	2738769	2738563
23	‡2738606	2738538	62	4739379	4739111	101	4739477	2738563
24	‡2738570	+4756444	64	4739380	4739111	104	4739333	+4756444
25	‡2738573	+4756444	66	4739357	4739111	105	4739333	2738563
29	‡2738603	4739111	69	4739370	2738563	106	8827030	4739111
29	‡2738570	4739111	71	4739333	4739111	107	4739333	2738548
31	‡2738544	4739111	73	4739370	2738548	109	4739357	2738548
34	2738748	+4756444	74	4739333	2738538	113	4739380	2738765
35	‡2738567	2738563	76	4739475	2738765	114	4739318	2738563
36	‡2738613	2738538	77	4739477	+4756444	115	4739486	2738548

Ref. No.	Number Required for Type 17CM15-																Cat.No.	Description
	AA	AT	BA	BB	BC	BD	CC	EE	FF	NN	RR	SS	TT	VV	YY			
	1	1	1	1			1	1	1	1	1	1	1		1	6713057	Rubber washer for operating coil	
	2	2	2	2	2	2	2	2	2	2	2	2	2	2	2	256488	Screw fastening operating coil to frame, 6-40	
3	1		1		1	1	1	1					1	1	1	4768903AC	Magnet frame	
3		1									1					4768903	Magnet frame	
3,4				1					1							130X70	Magnet frame with dowel pin	
3,4										1						4731776G8	Magnet frame with core	
3,4											1					4737948G1	Magnet frame with core	
4	1		1	1	1	1	1	1	1				1	1	1	4709833AA	Magnet core for operating coil	
4		1										1				4709833	Magnet core for operating coil	
	1	1	1	1	1	1	1	1	1	1	1	1	1	1	1	6713726	Insulation between magnet frame and base	
										1						6711820	Plug for magnet core	
										1						227X81	Set screw for plug, 6-40	
							x				1	1	1			4715554	Sleeve for magnet core	
							x				1	1	1			4715583	Washer under head of magnet core	
	1	1	1		1	1	1	1				1	1	1	1	112303	Screw fastening magnet core to frame, 5/16 in.-18	
				1												4710329	Stud fastening magnet core to frame, 5/16 in.-18	
									1							446178	Stud fastening magnet core to frame, 5/16 in.-18	
	AA	AT	BA	BB	BC	BD	CC	EE	FF	NN	RR	SS	TT	VV	YY			

+ Includes stationary contact support

Δ For Types 17CM15AT29 and 17CM15C29 Contactors only

‡ For Type 17CM15NN29 Contactor only

† See page 6 for table of new design operating coils

x Quantity variable

TYPE 17CM15 CONTACTORS

GEF-3211B

Ref. No.	Number Required for Type 17CM15-																Cat.No.	Description
	AA	AT	BA	BB	BC	BD	CC	EE	FF	NN	RR	SS	TT	VV	YY			
	2	2	2		2	2	2				2	2	2	2	2	46X847	Screw fastening magnet frame to base, 1/4 in.-20	
5	1			1	1	1		1	1						1	4737858AB	Armature stop	
5		1								1	1	1	1			4737858AE	Armature stop	
5			1													4737858BD	Armature stop	
5							1									4737858AC	Armature stop	
5														1		4737858AA	Armature stop	
	2	2	2	2		2		2	2	2	2	2	2		2	20X555	Screw fastening armature stop to magnet frame, 1/4 in.-20	
					2		2								2	36X712	Screw fastening armature stop to magnet frame, 1/4 in.-20	
6	1			1	1	1	1	1	1						1	6742072G1	Armature with spring bracket	
6		1									1					4725984G9	Armature	
6			1									1	1			6742072G8	Armature	
6									1							4725754G3	Armature	
6										1						4725754G1	Armature	
		1	1						1	1	1	1	1			6706034	Spring bracket for armature	
		1														8801382	Spacer for spring bracket	
		1	1						1	1	1	1	1			50X499	Screw fastening spring bracket to armature, 1/4 in.-20	
7	1	1	1	1	1	1	1	1	1	1	1				1	4769764	Tension spring with plug, for armature	
7												1				6721200	Tension spring with plug, for armature	
7													1	1		4769687	Tension spring with plug, for armature	
8	1			1	1	1	1	1	1						1	6700342	Adjusting screw for tension spring, 10-32	
8		1	1							1	1	1	1	1		6706033	Adjusting screw for tension spring, 10-32	
9	1		1			1		1					1		1	4711038	Contact lever with bushing	
9		1		1	1		1		1	1	1	1		1		4711039	Contact lever with bushing	
	1	1	1	1	1	1	1	1	1	1	1	1	1	1	1	4750841	π Bushing for contact lever	
10	1	1	1	1	1	1	1	1	1	1	1	1	1	1	1	4709826	Hinge pin for contact lever	
11	1	1	1	1	1	1	1	1	1				1	1		4769765	Compression spring for contact lever	
11					1					1	1					4734973	Compression spring for contact lever	
11																6721211	Compression spring for contact lever	
11															1	4735982	Compression spring for contact lever	
12	1		1			1		1					1		1	6721611G1	Flexible shunt for contact lever	
12		1		1	1		1		1	1	1	1		1		6721605G1	Flexible shunt for contact lever	
13	1	1	1		1	1	1	1		1	1	1	1	1	1	46X801	Screw fastening flexible shunt to armature stop, 1/4 in.-20	
13				1					1							48X38	Screw fastening flexible shunt to armature stop, 1/4 in.-20	
14	2		2												2	4711042	Contact tip	
14		2			2		2		2	2	2	2		2		4715358	Contact tip	
14				2												4709829	Contact tip	
14						2		2					2			4711041	Contact tip	
15	1		1			1		1					1		1	4715190	Arcing horn for contact lever	
15		1		1	1		1		1	1				1		4709848	Arcing horn for contact lever	
16	1		1			1		1					1		1	91X85	Screw fastening contact tip, flexible shunt, and arcing horn to contact lever, 1/4 in.-20	
16		1			1		1			1	1	1		1		87X743	Screw fastening contact tip, flexible shunt, and arcing horn to contact lever, 10-32	
16				1												128616	Screw fastening contact tip, flexible shunt, and arcing horn to contact lever, 10-32	
16									1							243X9	Screw fastening contact tip, flexible shunt, and arcing horn to contact lever, 10-32	
17	§		§			§		§					§		§	-----	Stationary contact support	

π Bushing may be replaced by using burnishing tool Cat.No. 4735725P2.

§ Included with blowout coil.

TYPE 17CM15 CONTACTORS

Ref. No.	Number Required for Type 17CM15-																Cat.No.	Description
	AA	AT	BA	BB	BC	BD	CC	EE	FF	NN	RR	SS	TT	VV	YY			
17		1		1	1		1		1	1				1		4768902	Stationary contact support	
17											1	1				4711077AA	Stationary contact support	
	1		1			1		1					1	1		4715165	Flange for blowout coil, with slot	
	1		1			1		1					1	1		4715162	Flange for blowout coil, without slot	
	1		1			1		1					1	1		4715164	Insulated core for blowout coil	
19	4	4	4	5	4	4	4	2	4	4			4	4	4	105136	Screw fastening blowout coil flange or contact tip to stationary contact, 10-32	
20	1		1			1		1					1	1		91X92	Screw fastening contact tip to stationary contact, 1/4 in.-20	
20		1			1		1		1	1	1	1		1		87X885	Screw fastening contact tip to stationary contact, 10-32	
								2								150751	Screw fastening blowout coil flange to stationary contact, 10-32, 1 in.	
								2								6700339	Insulation bushing for Cat. 150751	
								2								6700347	Insulation spacer for Cat. 150751	
21	1	1	1	1	1	1	1	1	1	1			1	1	1	4709831	Insulation shield for blowout coil	
										1	1					6706168	Spacer between stationary contact and base	
	2	2	2		2	2	2			2			2	2	2	145995	Screw fastening stationary contact support to base, 10-32	
			2													171882	Screw fastening stationary contact support to base, 10-32	
								2								154900	Screw fastening stationary contact support to base, 10-32	
										2	2					46X820	Screw fastening stationary contact support to base, 1/4 in.-20	
22	1		1			1		1					1	1		2735210G3	Arc chute	
22		1		1	1		1		1	1				1		2735210G1	Arc chute	
23	1		1			1		1					1		1	4759978	Hinge pin for arc chute	
23		1		1	1		1		1	1				1		4759974	Hinge pin for arc chute	
24		1		1	1		1		1	1				1		6702274	Stop for arc chute	
			1	1	1		1		1					1		4731833P6	Screw fastening stop to support, 10-32	
25	1		1			1	1		1				1	1		4711271	Mounting base	
25					1											8827191	Mounting base	
25								1								6700540	Mounting base	
25										1	1					6706598	Mounting base	
25												1				6703942	Mounting base	
26	1		1			1							1		1	4715166	Terminal post for blowout coil	
26		1				1				1				1		4711270	Terminal post for blowout coil	
26			1													4710330	Terminal post for blowout coil	
26								1								4709847	Terminal post for blowout coil	
							2									20X555	Terminal screw for blowout coil, 1/4 in.-20	
27		1		1		1		1	1					1		6711633	Connection strip for blowout coil lead	
				1												8831234G1	Hand operating mechanism with spring	
				1												2766782	Spring for hand operating mechanism	
				1												8831234P14	Knob for hand operating mechanism	
				1												75X12	Screw fastening knob in position	
				1												4731833P9	Adjusting screw for mechanism, 10-32	
				2												145995	Screw fastening mechanism to base, 10-32	
	AA	AT	BA	BB	BC	BD	CC	EE	FF	NN	RR	SS	TT	VV	YY			

TYPE 17CM15 CONTACTORS

GEF-3211B

NOTE:- The following items are steel unless otherwise specified.

PLAIN WASHERS	
Cat.No.	Description
196351	For No. 6 screw
150279	For No. 10 screw, 13/32 in. O.D.
165736	For No. 10 screw, 5/8 in. O.D.
143974	For 1/4 in. screw
145598	For 5/16 in. screw, 5/8 in. O.D.
147674	For 5/16 in. screw, 7/8 in. O.D.

LOCK WASHERS	
Cat.No.	Description
54X595	For No. 6 screw
54X441	For No. 10 screw
71X749	For No. 10 screw, Shakeproof
30X562	For 1/4 in. screw
6X814	For 5/16 in. screw

NUTS	
Cat.No.	Description
145996	10-32, hex. std
1X452	1/4 in.-20, hex. std
126869	5/16 in.-18, hex. std

COTTER PIN	
Cat.No.	Description
168996	1/16 in. by 3/8 in.

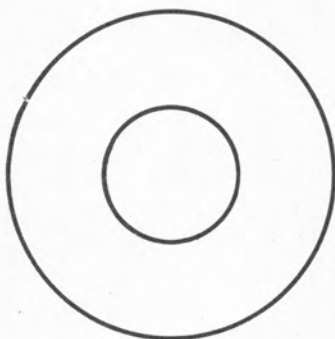

(ART PBA76760) *FIG. 1*



FIG. 2 (ART PBA76761)

Two designs of operating coils have been furnished for the Type 17CM15 Contactor. The first design of operating coil Fig. 1 has round spool flanges at both ends; the second design Fig. 2 has one round and one offset spool flange which provides for fastening to the contactor frame by using two 6-40, 3/8 in. r.h. screws Cat.No. 256488. This design prevents breaking connections by the turning of the operating coil.

TYPE 17CM15 CONTACTORS

Operating Coils listed in this table are interchangeable, except that the contactor frame must be machined in accordance with Fig. 3 before the operating coils of the second design can be applied. The rubber washer used with operating coils of the first design Fig. 1 is not required for the second design Fig. 2.

Operating Coil	Cat.No.
Fig. 1 Design	Fig. 2 Design
2738101	4739333
2738434	4739472
2738516	4739401
2738544	4739477
2738567	4739357
2738570	4739333
2738573	4739370
2738603	4739475
2738606	4739486
2738613	4739318
2738649	4739393

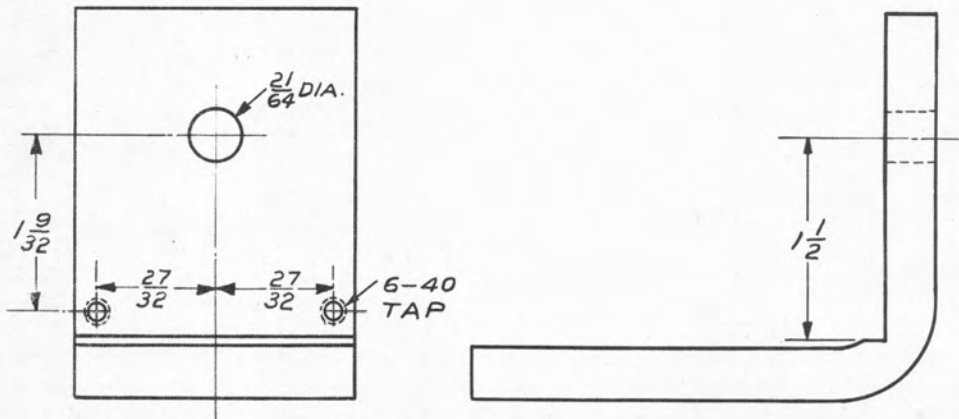

FIG. 3

- 1 Remove partial radius in bend of frame as shown.
- 2 Drill and tap frame locating two tapped holes from the center of the present 21/64 in. diam hole in frame.
- 3 Place new design coil retainer furnished with coil between core body and coil spool with long end inside coil and short end under core head.

INDEX OF CATALOG NUMBERS

Catalog identifications in this index are arranged in order, reading from *left to right*, first alphabetically according to the prefix letter or letters, if used, and second numerically.

In this index all numbers with a letter prefix will precede those without prefixes.

The number of letters or digits does not affect placement in the table, thus A1999999 will precede A2, and ZZ9999999 will precede Cat. No. 1 (number without a prefix). Letters take precedence over numbers so that Cat. No. 26F1 will precede Cat. No. 261.

Cat. No.	Page	Cat. No.	Page	Cat. No.	Page	Cat. No.	Page
1X452-----	5	2738603-----	2,6	4725984G9 ---	3	4769764-----	3
105136-----	4	2738606-----	2,6	4731776G8 ---	2	48X38 -----	3
112303-----	2	2738748-----	2	4731833P6 ---	4	50X499 -----	3
126869-----	5	2738765-----	2	4731833P9 ---	4	54X441 -----	5
128616-----	3	2738769-----	2	4734973-----	3	54X595 -----	5
130X70-----	2	2766782-----	4	4735982-----	3	6X814 -----	5
143974-----	5	30X562 -----	5	4737858AA ---	3	6700339-----	4
145598-----	5	36X712 -----	3	4737858AB ---	3	6700342-----	3
145995-----	4	446178-----	2	4737858AC ---	3	6700347-----	4
145996-----	5	46X801 -----	3	4737858AE ---	3	6700540-----	4
147674-----	5	46X820 -----	4	4737858BD ---	3	6702274-----	4
150279-----	5	46X847 -----	3	4737948G1 ---	2	6703942-----	4
150751-----	4	4709826-----	3	4739111-----	2	6706033-----	3
154900-----	4	4709829-----	3	4739318-----	2,6	6706034-----	3
165736-----	5	4709831-----	4	4739333-----	2,6	6706168-----	4
168996-----	5	4709833-----	2	4739357-----	2,6	6706598-----	4
171882-----	4	4709833AA ---	2	4739370-----	2,6	6711633-----	4
196351-----	5	4709847-----	4	4739379-----	2	6711820-----	2
20X555-----	3,4	4709848-----	3	4739380-----	2	6713057-----	2
227X81-----	2	4710329-----	2	4739393-----	2,6	6713726-----	2
243X9-----	3	4710330-----	4	4739458-----	2	6721200-----	3
256488-----	2,5	4711038-----	3	4639472-----	2,6	6721211-----	3
2735210G1 ---	4	4711039-----	3	4739475-----	2,6	6721605G1 ---	3
2735210G3 ---	4	4711041-----	3	4739477-----	2,6	6721611G1 ---	3
2738184-----	2	4711042-----	3	4739486-----	2,6	6742072G1 ---	3
2738101-----	2,6	4711077AA ---	4	4739401-----	6	6742072G8 ---	3
2738434-----	2,6	4711270-----	4	4749172-----	2	71X749 -----	5
2738516-----	2,6	4711271-----	4	4750841-----	3	75X12 -----	4
2738538-----	2	4715162-----	4	4756444-----	2	87X743 -----	3
2738544-----	2,6	4715165-----	4	4757835-----	2	87X885 -----	4
2738548-----	2	4715166-----	4	4759974-----	4	8801382-----	3
2738563-----	2	4715190-----	3	4759978-----	4	8827030-----	2
2738567-----	2,6	4715358-----	3	4768902-----	4	8827191-----	4
2738570-----	2,6	4715554-----	2	4768903-----	2	8831234G1 ---	4
2738573-----	2,6	4715583-----	2	4768903AC ---	2	8831234P14 ---	4
2738613-----	2,6	4725754G1 ---	3	4769675-----	3	91X85 -----	3
2738649-----	2,6	4725754G3 ---	3	4769687-----	3	91X92 -----	4

WHEN YOU NEED SERVICE

IF YOU NEED TO REPAIR, recondition, or rebuild any electric apparatus, a G-E service shop near you is available day and night, seven days a week, for work in the shops or on your premises. Latest factory methods and genuine G-E renewal parts are used to maintain the original performance of your G-E equipment. For full information about these services, contact the nearest service shop or sales office listed below:

APPARATUS SERVICE SHOPS

Allentown, Pa. 672-676 E. Highland St.
 Appleton, Wisc. Midway Industrial Area,
 County Trunk, "P"
 Atlanta—Chamblee, Ga. 4639 Peachtree
 Indus. Blvd.
 Baltimore 30, Md. 920 E. Fort Ave.
 Boston—Medford 55, Mass. Mystic Valley Pkwy.
 Buffalo 11, N. Y. 318 Urban St.
 Charleston 28, W. Va. 306 MacCorkle Ave., S.E.
 Charlotte, N. C. 2328 Thrift Road
 Chicago 32, Ill. 4360 W. 47th St.
 Cincinnati 2, Ohio 444 W. Third St.
 Cleveland 4, Ohio 4966 Woodland Ave.
 Columbus 23, Ohio 2128 Eakin Rd.
 Corpus Christi, Texas 115 Busse St.
 Dallas 19, Texas 3202 Manor Way
 Davenport—Bettendorf, Ia. 1039 State St.
 Decatur, Ill. 2225 E. Logan St.
 Denver 5, Colo. 3353 Larimer St.
 Detroit 2, Mich. 5950 Third Ave.
 Houston 20, Texas 5534 Harvey Wilson Drive
 Indianapolis 22, Ind. 1740 W. Vermont St.
 Johnstown, Pa. 841 Oak St.
 Kansas City, Mo. 3525 Grand Ave.
 Los Angeles 1, Calif. 6900 Stanford Ave.
 Louisville, Ky. 2014 New Main St.
 Midland, Tex. 3404 Bankhead Hwy.
 Milwaukee 3, Wisc. 940 W. St. Paul Ave.
 Minneapolis 12, Minn. 2025 49th Ave., N.
 New Orleans, La. 2815 N. Robertson St.
 New York—N. Bergen, N. J. 6001 Tonnelle Ave.
 Oakland, Calif. 1525 Peralta St.
 Philadelphia 24, Pa. 1040 E. Erie Ave.
 Pittsburgh 6, Pa. 6519 Penn Ave.
 Portland 10, Oregon 2727 N.W. 29th Ave.
 Richmond 24, Va. 1403 Ingram Ave.
 Roanoke, Va. 115 Albermarle St.
 Sacramento, Calif. 99 N. 17th St.
 St. Louis 10, Mo. 1115 East Road
 Salt Lake City 4, Utah 301 S. Seventh West St.
 San Francisco 3, Calif. 1098 Harrison St.
 Seattle 4, Wash. 3422 First Ave., S.
 Southington, Conn. 53 Railroad Ave.
 Spokane 3, Wash. S. 155 Sherman St.
 Tampa 1, Fla. P.O. Box 1245,
 Naval Indus. Res. Shipyard
 Toledo 4, Ohio 1 So. St. Clair St.
 Wheeling, W. Va. 2050 National Rd.
 York, Pa. 54 N. Harrison St.
 Youngstown 5, Ohio 272 E. Indianola Ave.

APPARATUS SALES OFFICES

Abilene, Texas 442 Cedar St.
 Akron 8, Ohio 335 S. Main St.
 Albany 7, N. Y. 90 State St.
 Albuquerque, N. Mex. 323 Third St., S.W.
 Alexandria, La. 720 Murray St.
 Allentown, Pa. 1132 Hamilton St.
 Amarillo, Texas Amarillo Bldg.
 Appleton, Wisc. 531 W. College Ave.
 Atlanta 3, Ga. 1860 Peachtree Rd., N.W.
 Augusta, Ga. Masonic Bldg.
 Augusta, Me. 152 State St.
 Baltimore 1, Md. 111 Park Ave.
 Bangor, Maine 77 Central St.
 Baton Rouge 6, La. 3170 Florida Blvd.
 Battle Creek, Mich. 25 W. Michigan Ave.
 Beaumont, Texas 1385 Calder Ave.
 Billings, Mont. Rm. 816, 303 No. Broadway
 Binghamton, N. Y. 19 Chenango St.

Birmingham 3, Ala. 1804 Seventh Ave., N.
 Bismarck, N. Dak. 418 Rosser Ave.
 Bluefield, W. Va. 704 Bland St.
 Appalachian Bldg.
 Boise, Idaho 1524 Idaho St.
 Boston 1, Mass. 140 Federal St.
 Buffalo 3, N. Y. 535 Washington St.
 Butte, Mont. P.O. Box 836, 103 N. Wyoming St.
 Canton 2, Ohio 700 Tuscarawas St., W.
 Cedar Rapids, Iowa 210 Second St., S.E.
 Charleston 28, W. Va. 306 MacCorkle Ave., S.E.
 Charlotte 1, N. C. 112 S. Tryon St.
 Chattanooga 2, Tenn. 832 Georgia Ave.
 Chicago 80, Ill. P.O. Box 5970A, 840 S. Canal St.
 Cincinnati 2, Ohio 215 W. Third St.
 Cleveland 4, Ohio 4966 Woodland Ave.
 Columbia 1, S.C., P.O. Box 1434, 1420 Lady St.
 Columbus 15, Ohio 40 S. Third St.
 Corpus Christi, Texas 205 N. Chaparral
 Dallas 2, Texas 1801 N. Lamar St.
 Davenport—Bettendorf, Ia. 1039 State St.
 Dayton 2, Ohio 11 W. Monument Bldg.
 Dayton 9, Ohio Avia. & Def.,
 2600 Far Hills Ave.
 Denver 2, Colo. 650 Seventeenth St.
 Des Moines 9, Iowa 505 W. Fifth Ave.
 Detroit 2, Mich. 700 Antoinette St.
 Duluth 2, Minn. 14 W. Superior St.
 Elmira, N. Y. Main and Woodlawn Aves.
 El Paso, Texas 215 No. Stanton
 Erie, Pa. 1001 State St.
 Eugene, Ore. Cascade Bldg., 1170 Pearl St.
 Evansville 19, Ind. 123 N.W. Fourth St.
 Fairmont, W. Va. 310 Jacobs Bldg.,
 P.O. Box 1626
 Fergus Falls, Minn. 108 N. Court Ave. P.O. Box 197
 Flint 3, Mich. 653 S. Saginaw St.
 Fort Wayne 6, Ind. 3606 So. Calhoun St.
 Fort Worth 2, Tex. 408 W. Seventh St.
 Fort Worth, Tex. Avia. & Def.,
 6200 Camp Bowie Blvd.
 Fresno 1, Calif. 407 Patterson Bldg.
 Tulare and Fulton St.
 Grand Rapids 2, Mich. 425 Cherry St., SE
 Greensboro, N. C. 301 S. Elm St.
 Greenville, S. C. 108 W. Washington St.
 Gulfport, Miss. 207 Jo-Fran Bldg.
 Hagerstown, Md. Professional Arts Bldg.
 Hartford 5, Conn. 764 Asylum Ave.
 Houston 1, Texas 1312 Live Oak St.
 Indianapolis 4, Ind. 110 N. Illinois St.
 Jackson, Mich. 120 W. Michigan Ave.
 Jackson 1, Miss. 203 W. Capitol St.
 Jacksonville 2, Fla. 700 E. Union St.
 Jamestown, N. Y. P.O. Box 548, 2 Second St.
 Johnstown, Pa. 841 Oak St.
 Joplin, Mo. P.O. Box 948, 220 1/2 W. Fourth St.
 Kalamazoo 3, Mich. 112 Parkway Ave.
 Kansas City 6, Mo. 106 W. Fourteenth St.
 Knoxville 16, Tenn. 1301 Hannah Ave.
 Lake Charles, La. 422 Seventh St.
 Lansing 8, Mich. 306 Michigan National Tower
 Lexington, Ky. First National Bank Bldg.
 Lincoln 8, Nebr. Sharpe Bldg., 206 S. 13th St.
 Little Rock, Ark. 103 W. Capitol Ave.
 Los Angeles 54, Calif. 212 N. Vignes St.
 Louisville 2, Ky. 455 S. Fourth St.
 Lubbock, Texas 3302 Avenue "A"
 Macon, Ga. 682 Cherry St.
 Madison 3, Wisc. 16 N. Carroll St.
 Manchester, N. H. 875 Elm St.

Medford, Ore., P.O. Box 1349, 107 E. Main St.
 Memphis 3, Tenn. 8 N. Third St.
 Miami 32, Fla. 25 S.E. Second Ave.
 Midwest City, Okla. Avia. & Def.,
 207 Post Off. Bldg.
 Milwaukee 3, Wisc. 940 W. St. Paul Ave.
 Minneapolis 3, Minn. 12 S. Sixth St.
 Mobile 13, Ala. 54 St. Joseph St.
 Nashville 3, Tenn. 234 Third Ave. N.
 Newark 2, N. J. 744 Broad St.
 New Haven 6, Conn. 129 Church St.
 New Orleans 12, La. 837 Gravier St.
 New York 22, N. Y. 570 Lexington Ave.
 New York Avia. & Def., Fed. Bldg.
 N. Y. International Airport, Jamaica 30, N. Y.
 Niagara Falls, N. Y. 253 Second St.
 Norfolk 10, Va. 229 W. Bute St.
 Oakland 12, Calif. 409 Thirteenth St.
 Oklahoma City 2, Okla. 119 N. Robinson St.
 Omaha 2, Nebr. 409 S. Seventeenth St.
 Pasco, Wash. 824 W. Lewis St.
 Peoria 2, Ill. 309 Jefferson Bldg.
 Philadelphia 2, Pa. 1405 Locust St.
 Phoenix, Ariz. P.O. Box 4037, 303 Luhrs Tower
 Pittsburgh 22, Pa. The Oliver Bldg., Mellon Sq.
 Portland 7, Ore. 920 S.W. Sixth Ave.
 Providence 3, R. I. Industrial Trust Bldg.
 Raleigh, N. C. Room 401, 16 W. Martin St.
 Reading, Pa. 31 N. Sixth St.
 Richmond 17, Va. 700 E. Franklin St.
 Riverside, Calif. 3570 Ninth St.
 Roanoke 16, Va. 920 S. Jefferson St.
 Rochester 4, N. Y. 89 E. Ave.
 Rockford, Ill. 110 S. First St.
 Rutland, Vt. 38 1/2 Center St.
 Sacramento 14, Calif. 626 Forum Bldg.
 Saginaw, Mich. Second National Bank Bldg.
 St. Louis 1, Mo. 818 Olive St.
 Salt Lake City 9, Utah 200 S. Main St.
 San Antonio 5, Texas 434 So. Main Ave.
 San Diego 1, Calif. 1240 Seventh Ave.
 San Francisco 6, Calif. 235 Montgomery St.
 San Jose 10, Calif. 460 Park Ave.
 Savannah, Ga. 4 E. Bryan St.
 Seattle 4, Wash. 710 Second Ave.
 Seattle 8, Wash. Avia. & Def., 220 Dawson St.
 Shreveport, La. 206 Beck Bldg.
 Sioux City 13, Iowa 572 Orpheum Electric Bldg.
 South Bend 1, Ind. 112 W. Jefferson Blvd.
 Spokane 4, Wash. S. 162 Post St.
 Springfield, Ill. 607 E. Adams St.
 Springfield 3, Mass. 1387 Main St.
 Stockton, Calif. 11 So. San Joaquin St.
 Syracuse 6, N. Y. 3532 James St.
 Tacoma 1, Wash. 1202 Washington Bldg.
 Tampa 6, Fla. 1206 North A St.
 Toledo 4, Ohio 420 Madison Ave.
 Trenton 8, N. J. 214 E. Hanover St.
 Tucson, Ariz. P.O. Box 710, 650 N. Sixth Ave.
 Tulsa 3, Okla. 320 S. Boston Ave.
 Utica 2, N. Y. 258 Genesee St.
 Washington 5, D. C. 777-14th St., N.W.
 Waterloo, Iowa 206 W. 4th St.
 Wenatchee, Wash. 328 N. Wenatchee Ave.
 Wheeling, W. Va. 40 Fourteenth St.
 Wichita 2, Kan. 200 E. First St.
 Williamston, N. C. 115 E. Main St.
 Worcester 5, Mass. 288 Grove St.
 York, Pa. 56 N. Harrison St.
 Youngstown 5, Ohio 272 E. Indianola Ave.

Hawaii: American Factors, Ltd., P. O. Box 3230, Honolulu 1 Canada: Canadian General Electric Company, Ltd., Toronto

LOCOMOTIVE AND CAR EQUIPMENT DEPARTMENT, GENERAL ELECTRIC COMPANY, ERIE, PA.



RENEWAL PARTS

TYPE GA-33 GEAR UNITS

Model Numbers

7GA33A1	7GA33B1	7GA33C1	7GA33D1	7GA33D5
7GA33A2	7GA33B2	7GA33C2	7GA33D2	7GA33D6
7GA33A3	7GA33B3	7GA33C3	7GA33D3	7GA33F1
7GA33A4	7GA33B4	7GA33C4	7GA33D4	7GA33F2

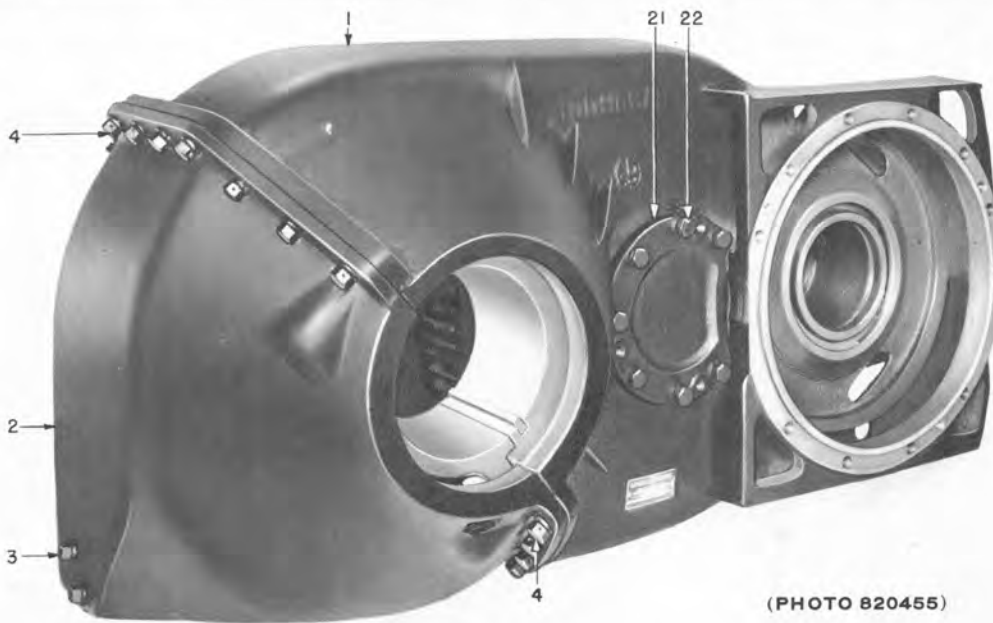

(PHOTO 820455)

Type GA-33-C1 railway reduction unit

Gear Units used with the Type GE-733 Motors were originally identified by the Motor Model No. and the Motor Serial No. which was stamped on the unit housing. These Gear Units are now identified by a separate Model No. For the convenience of customers the following table gives the cross reference from Serial No. to Model No.

Example:- Serial No. 1710144 is now identified as Model No. 7GA33A1.

Serial No.	Model No.	Serial No.	Model No.	Serial No.	Model No.	Serial No.	Model No.
1710144-148	7GA33A1	1710170	7GA33C3	1710698	7GA33A2	1710721	7GA33B1
1710149	7GA33A2	1710171-178	7GA33A1	1710699	7GA33A1	1710722-724	7GA33A2
1710150	7GA33A1	1710179	7GA33A4	1710700-702	7GA33A2	1710785	7GA33A2
1710152-154	7GA33A2	1710180-183	7GA33A1	1710703	7GA33C3	1710787	7GA33C2
1710155	7GA33A1	1710685	7GA33A2	1710704-706	7GA33A2	1710788-790	7GA33A2
1710156	7GA33A2	1710686	7GA33C2	1710707	7GA33A1	1710792-793	7GA33A1
1710157	7GA33A1	1710687	7GA33A2	1710708	7GA33C2	1710794	7GA33A2
1710158	7GA33A2	1710688	7GA33C4	1710710-712	7GA33A2	1710795-797	7GA33A1
1710159	7GA33A1	1710689-690	7GA33A2	1710713	7GA33A1	1710798	7GA33A2
1710160	7GA33C2	1710691	7GA33C4	1710714	7GA33A2	1710799-804	7GA33A1
1710161	7GA33B1	1710692-694	7GA33A2	1710715	7GA33C2	1710807	7GA33C4
1710162-165	7GA33A1	1710695	7GA33A1	1710716	7GA33A2	1710808-809	7GA33C2
1710166	7GA33A2	1710696	7GA33A2	1710717	7GA33A1	1710810-815	7GA33C4
1710167-169	7GA33A1	1710697	7GA33C4	1710718-720	7GA33A2	1710816	7GA33A2

When ordering renewal parts, give quantity, catalog number, description of each item required, and complete nameplate reading.



TYPE GA-33 GEAR UNITS

Serial No.	Model No.	Serial No.	Model No.	Serial No.	Model No.	Serial No.	Model No.
1710817-818	7GA33C4	1800133	7GA33A1	1800404	7GA33C4	1800601	7GA33C1
1710819	7GA33C1	1800134	7GA33C1	1800405	7GA33B1	1800602-605	7GA33C4
1710820	7GA33C4	1800135	7GA33A2	1800406	7GA33A4	1800606	7GA33C1
1710821	7GA33C1	1800136	7GA33C3	1800407-408	7GA33B1	1800607	7GA33C4
1710822	7GA33C2	1800137-138	7GA33A1	1800409	7GA33A4	1800608	7GA33B1
1710823-826	7GA33C4	1800139	7GA33A2	1800410-411	7GA33B1	1800609	7GA33C4
1710874-880	7GA33A2	1800140	7GA33A1	1800412	7GA33A1	1800610-611	7GA33C1
1710881	7GA33C1	1800141-142	7GA33A2	1800413	7GA33A2	1800612	7GA33C2
1710882-884	7GA33A1	1800310-311	7GA33A2	1800414-416	7GA33C4	1800613	7GA33C4
1710885	7GA33A2	1800312-313	7GA33B1	1800417	7GA33C2	1800614	7GA33A2
1710886-887	7GA33A1	1800314	7GA33A1	1800418	7GA33C4	1800615	7GA33C4
1710888	7GA33A2	1800315	7GA33C4	1800419	7GA33B4	1800616	7GA33C1
1710889	7GA33A1	1800316	7GA33C1	1800420	7GA33C4	1800618	7GA33C4
1710890-891	7GA33A2	1800317-318	7GA33A2	1800421	7GA33A1	1800619-620	7GA33C1
1710892-894	7GA33A1	1800319	7GA33C1	1800422	7GA33A4	1800621	7GA33C4
1710895	7GA33A2	1800320-321	7GA33A2	1800423	7GA33A2	1800622	7GA33B1
1710931	7GA33A2	1800322-323	7GA33A1	1800424	7GA33B1	1800623	7GA33C4
1710932	7GA33A1	1800324	7GA33C1	1800425-426	7GA33C4	1800624	7GA33B1
1711103	7GA33A2	1800325-327	7GA33A2	1800427	7GA33C1	1800625	7GA33C1
1711104	7GA33A1	1800328	7GA33A1	1800428	7GA33A1	1800626	7GA33B1
1711105-108	7GA33A2	1800329	7GA33B2	1800430	7GA33A4	1800627-629	7GA33C1
1711109	7GA33A1	1800330	7GA33A2	1800431	7GA33B2	1800630	7GA33B1
1711110-133	7GA33A2	1800331	7GA33A1	1800432	7GA33C4	1800631	7GA33C4
1711134	7GA33A1	1800333-336	7GA33A1	1800433	7GA33B1	1800632	7GA33C1
1711135-142	7GA33A2	1800337	7GA33B2	1800434-435	7GA33C4	1800633	7GA33C4
1800056	7GA33B1	1800338-339	7GA33A2	1800436	7GA33C1	1800634	7GA33B1
1800057	7GA33A1	1800340	7GA33C3	1800437	7GA33B1	1800635	7GA33C1
1800058	7GA33B1	1800341	7GA33A1	1800438-439	7GA33A2	1800636-637	7GA33C4
1800059-060	7GA33A2	1800342	7GA33C3	1800548-549	7GA33C4	1800638	7GA33C1
1800061-064	7GA33A1	1800343	7GA33B2	1800550	7GA33A4	1800639	7GA33C2
1800065-066	7GA33A2	1800344-345	7GA33C3	1800551	7GA33C4	1800640	7GA33A2
1800067	7GA33B1	1800346	7GA33C1	1800552	7GA33A2	1800641-643	7GA33C1
1800068-071	7GA33A2	1800347-348	7GA33A2	1800553	7GA33C4	1800644	7GA33C4
1800072	7GA33A1	1800349-350	7GA33A1	1800554	7GA33A2	1800645	7GA33C1
1800073-077	7GA33A2	1800351	7GA33C3	1800555	7GA33A1	1800646	7GA33B1
1800078-079	7GA33A1	1800352	7GA33A1	1800556-558	7GA33C4	1800647	7GA33C4
1800080	7GA33B1	1800353-354	7GA33A2	1800559-560	7GA33C2	1800648	7GA33D1
1800081	7GA33A2	1800355	7GA33C3	1800561-564	7GA33C4	1800649-653	7GA33C4
1800082-085	7GA33A1	1800356	7GA33A2	1800565-566	7GA33C1	1800654-655	7GA33C1
1800086-087	7GA33A2	1800357	7GA33C3	1800567	7GA33A2	1800656	7GA33C2
1800088-089	7GA33A1	1800358	7GA33A1	1800568	7GA33C1	1800657	7GA33C1
1800090	7GA33A2	1800359-360	7GA33C3	1800569	7GA33B1	1800658	7GA33C4
1800091-092	7GA33A1	1800361-362	7GA33A1	1800570	7GA33A2	1800659	7GA33B1
1800093-094	7GA33A2	1800363	7GA33C3	1800571	7GA33C4	1800660	7GA33B4
1800095	7GA33A1	1800364	7GA33A2	1800572-574	7GA33B1	1800661	7GA33A2
1800096-097	7GA33A2	1800365-366	7GA33C3	1800575	7GA33A4	1800662	7GA33C2
1800098-099	7GA33A1	1800367	7GA33A1	1800576	7GA33C4	1800663-664	7GA33C4
1800100	7GA33A2	1800368-370	7GA33C3	1800577	7GA33A2	1800665	7GA33B1
1800101-103	7GA33A1	1800371-373	7GA33A2	1800578	7GA33C1	1800666-667	7GA33C1
1800104-108	7GA33A2	1800374-375	7GA33A1	1800579	7GA33B1	1800668	7GA33B1
1800109	7GA33C3	1800376	7GA33C1	1800580	7GA33C1	1800669	7GA33C4
1800110	7GA33A1	1800377	7GA33B1	1800581	7GA33C4	1800671	7GA33C2
1800111	7GA33A2	1800378	7GA33B4	1800582	7GA33A4	1800672	7GA33B1
1800112	7GA33A1	1800379	7GA33A2	1800583	7GA33C1	1800673	7GA33C2
1800113	7GA33A2	1800380-381	7GA33A1	1800584	7GA33A4	1800674-676	7GA33C1
1800114	7GA33C2	1800382-383	7GA33A4	1800585	7GA33A2	1800677	7GA33C4
1800115-116	7GA33A1	1800384-385	7GA33A1	1800586-587	7GA33C1	1800678-679	7GA33C1
1800117-118	7GA33A2	1800386	7GA33A4	1800588	7GA33A2	1800680-681	7GA33C2
1800119	7GA33A1	1800387-391	7GA33C1	1800589-590	7GA33C1	1800682	7GA33C4
1800120	7GA33A2	1800392-393	7GA33B1	1800591	7GA33C4	1800683	7GA33B1
1800121-122	7GA33A1	1800394	7GA33C1	1800592-593	7GA33A4	1800684	7GA33D1
1800123	7GA33A2	1800395-396	7GA33B1	1800594	7GA33C1	1800685	7GA33C2
1800124	7GA33A1	1800397	7GA33A2	1800595	7GA33B1	1800686	7GA33C4
1800125-128	7GA33A2	1800398	7GA33C1	1800596-597	7GA33C1	1800687	7GA33A3
1800129-130	7GA33A1	1800399	7GA33B1	1800598	7GA33B1	1800688	7GA33C4
1800131	7GA33C3	1800400-402	7GA33C1	1800599	7GA33C1	1800689	7GA33C2
1800132	7GA33A2	1800403	7GA33A4	1800600	7GA33C4	1800690-691	7GA33C4

TYPE GA-33 GEAR UNITS

GEF-3264C

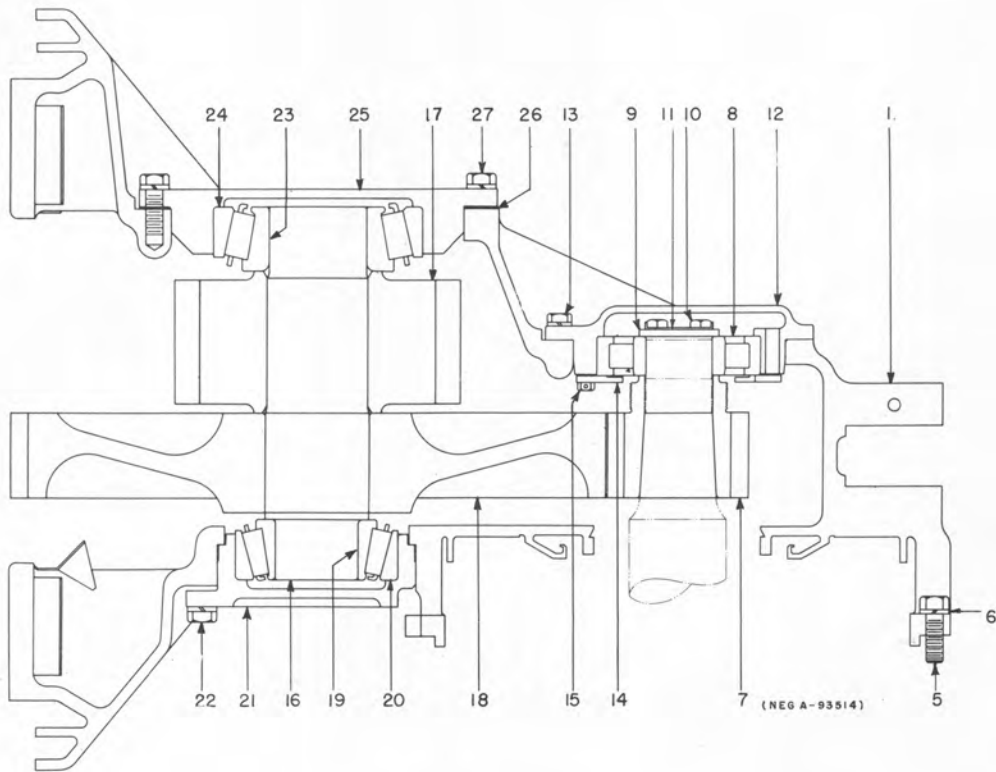

Longitudinal section of unit

Serial No.	Model No.	Serial No.	Model No.	Serial No.	Model No.	Serial No.	Model No.
1800692	7GA33C2	1801100-101	7GA33C1	1801901-914	7GA33C2	1802059-062	7GA33C2
1800693-694	7GA33D1	1801104-112	7GA33C1	1802012-014	7GA33C2	1802064	7GA33C2
1800695	7GA33B1	1801114-117	7GA33C1	1802016-017	7GA33C2	1802178-180	7GA33C2
1800696	7GA33C2	1801120	7GA33C1	1802018	7GA33C1	1802194-195	7GA33C2
1800697-699	7GA33C4	1801887-888	7GA33C1	1802019-020	7GA33C2	1802196	7GA33C4
1801081-085	7GA33C1	1801889-891	7GA33C2	1802022-028	7GA33C2	1802197	7GA33C2
1801088-089	7GA33C1	1801893-894	7GA33C2	1802031-036	7GA33C2	1802198-199	7GA33C4
1801091-094	7GA33C1	1801896	7GA33C2	1802037-046	7GA33C2	1802200	7GA33C2
1801097	7GA33C1	1801897	7GA33B4	1802048-051	7GA33C2	1802201	7GA33C4
1801099	7GA33C1	1801898-899	7GA33C2	1802057	7GA33C2	1890114	7GA33A2

TYPE GA-33 GEAR UNITS

Ref. No.	Number Required for Model 7GA33-																	Catalog Number	Description			
	Number Required for Model 7GA33-																					
	A1	A2	A3	A4	B1	B2	B3	B4	C1	C2	C3	C4	D1	D2	D3	D4	D5			D6	F1	F2
1	-	1	-	1	-	-	-	-	-	-	-	-	-	-	-	-	-	-	-	-	4759269	Gear box with axle bearing caps
1	-	-	-	-	1	1	1	-	-	-	-	-	-	-	-	-	-	-	-	-	114X38	Gear box with axle bearing caps
1	1	-	1	-	-	-	-	1	1	1	1	-	-	-	-	-	-	-	-	-	114X39	†Gear box with axle bearing caps
1	-	-	-	-	-	-	-	-	-	-	-	1	1	1	1	1	1	1	1	1	114X40	Gear box with axle bearing caps
8	8	8	8	8	8	8	8	8	8	8	8	8	8	8	8	8	8	8	8	8	599X52	§Nut, 1 in. -14, heavy hex. slotted, 63/64 in. nominal thickness, 1 5/8 in. across flats, for axle cap stud
8	8	8	8	8	8	8	8	8	8	8	8	8	8	8	8	8	8	8	8	8	8819383	§Bolt fastening axle cap to gear box
8	8	8	8	8	8	8	8	8	8	8	8	8	8	8	8	8	8	8	8	8	8819384	§Washer for axle cap bolt
2	1	1	1	1	-	-	-	1	1	1	1	-	-	-	-	-	-	-	-	-	127X28	Cover for gear box
2	-	-	-	-	1	1	1	-	-	-	-	1	1	1	1	1	1	1	1	1	127X29	Cover for gear box
3	3	3	3	3	3	3	3	3	3	3	3	3	3	3	3	3	3	3	3	3	6705244P1	Pipe plug for gear box or cover
2	2	2	2	2	2	2	2	2	2	2	2	2	2	2	2	2	2	2	2	2	6726201P1	Gasket for gear box cover
4	20	20	20	20	20	20	20	20	20	20	20	20	20	20	20	20	20	20	20	20	945X81	Bolt fastening cover to gear box
5	10	10	10	10	10	10	10	10	10	10	10	10	10	10	10	10	10	10	10	10	186V704P1	Bolt fastening gear box to motor
6	30	30	30	30	30	30	30	30	30	30	30	30	30	30	30	30	30	30	30	30	N405P47	Lock washer, 5/8 in.
7	1	1	1	1	1	1	1	1	1	1	1	1	1	1	1	1	1	1	1	1	4767988	Pinion (15 teeth) for motor armature shaft
7	-	-	-	-	-	-	-	-	-	-	-	1	-	-	-	-	-	-	-	-	4767997	Pinion (17 teeth) for motor armature shaft
7	-	-	-	-	-	-	-	-	-	-	-	-	-	-	-	-	-	-	-	-	8828158	Pinion (17 teeth) for motor armature shaft
7	-	-	-	-	-	-	-	-	-	-	-	-	-	-	-	-	-	-	-	-	8828172P1	Pinion (17 teeth) for motor armature shaft
8	1	1	1	1	1	1	1	1	1	1	1	1	1	1	1	1	1	1	1	1	8864951P49	Pinion (18 teeth) for motor armature shaft
9	1	1	1	1	1	1	1	1	1	1	1	1	1	1	1	1	1	1	1	1	6705174	Roller bearing for armature shaft
10	2	2	2	2	2	2	2	2	2	2	2	2	2	2	2	2	2	2	2	2	N22P29016B	Retaining plate for armature shaft roller bearing
11	1	1	1	1	1	1	1	1	1	1	1	1	1	1	1	1	1	1	1	1	6705240	Bolt fastening retaining plate to shaft, 1/2 in. -13, 1 in. hex. hd.
12	1	1	1	1	1	1	1	1	1	1	1	1	1	1	1	1	1	1	1	1	4729501P1	Lock washer for two 1/2 in. bolts
13	6	6	6	6	6	6	6	6	6	6	6	6	6	6	6	6	6	6	6	6	N22P29020B	Bearing housing for armature shaft roller bearing
14	6	6	6	6	6	6	6	6	6	6	6	6	6	6	6	6	6	6	6	6	N405P45	Bolt fastening bearing housing to gear box, 1/2 in. -13, 1 1/4 in. hex. hd.
15	5	5	5	5	5	5	5	5	5	5	5	5	5	5	5	5	5	5	5	5	6705172P1	Lock washer, 1/2 in.
16	1	1	1	1	1	1	1	1	1	1	1	1	1	1	1	1	1	1	1	1	6705224	Retaining ring for armature shaft roller bearing
16	1	1	1	1	1	1	1	1	1	1	1	1	1	1	1	1	1	1	1	1	6726038P1	Bolt fastening retaining ring to bearing housing
17	1	-	-	-	-	-	-	-	-	-	-	-	-	-	-	-	-	-	-	-	8837739	Intermediate shaft
17	1	-	-	-	-	-	-	-	-	-	-	-	-	-	-	-	-	-	-	-	4767989	Intermediate shaft and pinion (17 teeth)
17	-	1	-	-	-	-	-	-	-	-	-	-	-	-	-	-	-	-	-	-	4767994	Pinion (23 teeth) for intermediate shaft
17	-	-	-	-	-	-	-	-	-	-	-	-	-	-	-	-	-	-	-	-	4767998	Pinion (15 teeth) for intermediate shaft
17	-	-	-	-	-	-	-	-	-	-	-	-	-	-	-	-	-	-	-	-	6726102	Pinion (18 teeth) for intermediate shaft
17	-	-	-	-	-	-	-	-	-	-	-	-	-	-	-	-	-	-	-	-	6726104	Pinion (23 teeth) for intermediate shaft

† When ordering gear box Cat. 114X39 as a first replacement for the Type GA-33-A1 or -A3 Unit suspension bolt Cat. 2760655P71, bushing Cat. 6719184 and seat Cat. 6723264P1, and safety angle Cat. 6723298G1 should also be ordered to compensate for the improved method of suspension.

§ Two types of fastenings have been furnished for the axle bearing cap. The first type was a stud and nut, of which the stud will no longer be supplied. The nut, as shown above, will be supplied. The present type is a bolt and washer. When ordering a first replacement for the stud, order Cat. 186V575G1 which includes bolt and washer, as shown above. After the first replacement either the bolt or washer may be ordered individually.

TYPE GA-33 GEAR UNITS

GEF-3264C

Ref. No.	Number Required for Model 7GA33-																Catalog Number	Description				
	A1	A2	A3	A4	B1	B2	B3	B4	C1	C2	C3	C4	D1	D2	D3	D4			D5	D6	F1	F2
17	1	1	1	1	1	1	1	1	1	1	1	1	1	1	1	1	1	1	1	1	6726103	Pinion (18 teeth) for intermediate shaft
18	1	1	1	1	1	1	1	1	1	1	1	1	1	1	1	1	1	1	1	1	2792468	Gear (76 teeth) for intermediate shaft
18	1	1	1	1	1	1	1	1	1	1	1	1	1	1	1	1	1	1	1	1	2792469	Gear (74 teeth) for intermediate shaft
18	1	1	1	1	1	1	1	1	1	1	1	1	1	1	1	1	1	1	1	1	8837738	Gear (88 teeth) for intermediate shaft
18	1	1	1	1	1	1	1	1	1	1	1	1	1	1	1	1	1	1	1	1	8837737	Gear (87 teeth) for intermediate shaft
19	1	1	1	1	1	1	1	1	1	1	1	1	1	1	1	1	1	1	1	1	8864953P18	Roller bearing for intermediate shaft, gear end
20	1	1	1	1	1	1	1	1	1	1	1	1	1	1	1	1	1	1	1	1	8864957P6	Cone with cage and rollers for roller bearing
20	1	1	1	1	1	1	1	1	1	1	1	1	1	1	1	1	1	1	1	1	8864956P6	Cup for roller bearing
21	1	1	1	1	1	1	1	1	1	1	1	1	1	1	1	1	1	1	1	1	4729502G1	Bearing housing for intermediate shaft bearing, gear end
22	7	7	7	7	7	7	7	7	7	7	7	7	7	7	7	7	7	7	7	7	952X56	Bolt fastening bearing housing to gear box, gear end
22	7	7	7	7	7	7	7	7	7	7	7	7	7	7	7	7	7	7	7	7	N405P47	Lock washer, 5/8 in.
23	1	1	1	1	1	1	1	1	1	1	1	1	1	1	1	1	1	1	1	1	8864953P21	Roller bearing for intermediate shaft, pinion end
24	1	1	1	1	1	1	1	1	1	1	1	1	1	1	1	1	1	1	1	1	8864957P7	Cone with cage and rollers for roller bearing
24	1	1	1	1	1	1	1	1	1	1	1	1	1	1	1	1	1	1	1	1	8864956P7	Cup for roller bearing
25	1	1	1	1	1	1	1	1	1	1	1	1	1	1	1	1	1	1	1	1	4729500P1	Bearing housing for intermediate shaft bearing, pinion end, (not prepared for speedometer mounting)
25	1	1	1	1	1	1	1	1	1	1	1	1	1	1	1	1	1	1	1	1	6726247P1	¶Bearing housing for intermediate shaft bearing, pinion end (for speedometer mounting)
25	1	1	1	1	1	1	1	1	1	1	1	1	1	1	1	1	1	1	1	1	9949152P1	Bearing housing for intermediate shaft bearing, pinion end, (not prepared for speedometer mounting)
26	1	1	1	1	1	1	1	1	1	1	1	1	1	1	1	1	1	1	1	1	4759948	Set of shims for bearing housing
26	3	3	3	3	3	3	3	3	3	3	3	3	3	3	3	3	3	3	3	3	6705171P1	Shim for bearing housing (0.003 in. thick)
26	3	3	3	3	3	3	3	3	3	3	3	3	3	3	3	3	3	3	3	3	6705171P2	Shim for bearing housing (0.005 in. thick)
26	2	2	2	2	2	2	2	2	2	2	2	2	2	2	2	2	2	2	2	2	6705171P3	Shim for bearing housing (0.025 in. thick)
26	1	1	1	1	1	1	1	1	1	1	1	1	1	1	1	1	1	1	1	1	6705171P4	Shim for bearing housing (0.063 in. thick)
26	1	1	1	1	1	1	1	1	1	1	1	1	1	1	1	1	1	1	1	1	930X20	Set of shims for bearing housing
26	1	1	1	1	1	1	1	1	1	1	1	1	1	1	1	1	1	1	1	1	6705171P1	Shim for bearing housing (0.003 in. thick)
26	1	1	1	1	1	1	1	1	1	1	1	1	1	1	1	1	1	1	1	1	6705171P2	Shim for bearing housing (0.005 in. thick)
26	1	1	1	1	1	1	1	1	1	1	1	1	1	1	1	1	1	1	1	1	6705171P3	Shim for bearing housing (0.025 in. thick)
27	9	9	9	9	9	9	9	9	9	9	9	9	9	9	9	9	9	9	9	9	952X56	Bolt fastening bearing housing to gear box, intermediate shaft, pinion end
27	9	9	9	9	9	9	9	9	9	9	9	9	9	9	9	9	9	9	9	9	N405P47	Lock washer, 5/8 in.
27	1	1	1	1	1	1	1	1	1	1	1	1	1	1	1	1	1	1	1	1	6726246P1	¶Support for speedometer
27	1	1	1	1	1	1	1	1	1	1	1	1	1	1	1	1	1	1	1	1	6705441	¶Gasket between support and bearing housing
27	9	9	9	9	9	9	9	9	9	9	9	9	9	9	9	9	9	9	9	9	N22P25016B	¶Bolt fastening support to bearing housing, 3/8 in. -16, 1 in. hex. hd.
27	9	9	9	9	9	9	9	9	9	9	9	9	9	9	9	9	9	9	9	9	N405P43	¶Lock washer, 3/8 in.
27	1	1	1	1	1	1	1	1	1	1	1	1	1	1	1	1	1	1	1	1	6705439	¶Driving stud for speedometer
27	1	1	1	1	1	1	1	1	1	1	1	1	1	1	1	1	1	1	1	1	N22P25010B	¶Bolt for end of intermediate shaft, 3/8 in. -16, 5/8 in. hex. hd.
27	1	1	1	1	1	1	1	1	1	1	1	1	1	1	1	1	1	1	1	1	6705440	¶Plate lock washer for 3/8 in. stud and screw

¶ Optional equipment.

TYPE GA-33 GEAR UNITS

INDEX OF CATALOG NUMBERS

Catalog identifications in this index are arranged in order, reading from *left to right*, first alphabetically according to the prefix letter or letters, if used, and second numerically.

In this index all numbers with a letter prefix will precede those without prefixes.

The number of letters or digits does not affect placement in the table, thus A1999999 will precede A2, and ZZ9999999 will precede Cat. No. 1 (number without a prefix). Letters take precedence over numbers so that Cat. No. 26F1 will precede Cat. No. 261.

Catalog Number	Page	Catalog Number	Page	Catalog Number	Page
N22P25010B----	5	4767989 -----	4	6726104 -----	4
N22P25016B----	5	4767994 -----	4	6726201P1 -----	4
N22P29016B----	4	4767997 -----	4	6726246P1 -----	5
N22P29020B----	4	4767998 -----	4	6726247P1 -----	5
N405P43 -----	5	599X52 -----	4	8819383 -----	4
N405P45 -----	4	6705171P1 ----	5	8819384 -----	4
N405P47 -----	4, 5	6705171P2 ----	5	8828158 -----	4
114X38 -----	4	6705171P3 ----	5	8828172P1 -----	4
114X39 -----	4	6705171P4 ----	5	8837738 -----	5
114X40 -----	4	6705172P1 ----	4	8837739 -----	4
127X28 -----	4	6705174 -----	4	8837771P1 -----	5
127X29 -----	4	6705224 -----	4	8864951P49 -----	4
186V575G1 ----	4	6705240 -----	4	8864953P18 -----	5
186V704P1 ----	4	6705244P1 ----	4	8864953P21 -----	5
2760655P71 ----	4	6705439 -----	5	8864956P6 -----	5
2792468 -----	5	6705440 -----	5	8864956P7 -----	5
2792469 -----	5	6705441 -----	5	8864957P6 -----	5
4729500P1 ----	5	6719184 -----	4	8864957P7 -----	5
4729501P1 ----	4	6723264P1 ----	4	930X20 -----	5
4729502G1 ----	5	6723298G1 ----	4	945X81 -----	4
4759269 -----	4	6726038P1 ----	4	952X56 -----	5
4759948 -----	5	6726102 -----	4	9949152P1 -----	5
4767988 -----	4	6726103 -----	5		

WHEN YOU NEED SERVICE

IF YOU NEED TO REPAIR, recondition, or rebuild any electric apparatus, a G-E service shop near you is available day and night, seven days a week, for work in the shops or on your premises. Latest factory methods and genuine G-E renewal parts are used to maintain the original performance of your G-E equipment. For full information about these services, contact the nearest service shop or sales office listed below:

APPARATUS SERVICE SHOPS

*Denotes Aircraft Service Shops

Albany, N. Y. 1097 Central Ave.
 Allentown, Pa. 668 E. Highland St.
 Appleton, Wisc. Midway Industrial Area,
 County Trunk, "P" P.O. Box 83
 Atlanta—Chamblee, Ga. 4639 Peachtree
 Indus. Blvd.
 *Arkansas City, Kan. P.O. Box 526
 Baltimore 30, Md. 920 E. Fort Ave.
 Boston—Medford 55, Mass. 3960 Mystic
 Valley Pkwy.
 Buffalo 11, N. Y. 318 Urban St.
 Charleston 28, W. Va. 306 MacCorkle Ave., S.E.
 Charlotte, N. C. 2328 Thrift Road
 Chicago 32, Ill. 4360 W. 47th St.
 Cincinnati 2, Ohio 444 W. Third St.
 *Cincinnati 3, Ohio 956 E. Court St.
 Cleveland 4, Ohio 4966 Woodland Ave.
 Columbus 23, Ohio 2128 Eakin Rd.
 Corpus Christi, Texas 115 Busse St.
 *Dallas, Texas 1135-1215 S. Lamar St.
 Dallas 19, Texas 3202 Manor Way
 Davenport—Bettendorf, Ia. 1039 State St.
 Decatur, Ill. 2225 E. Logan St.
 Denver 5, Colo. 3353 Larimer St.
 Detroit 2, Mich. 5950 Third Ave.
 Ft. Wayne, Ind. 606 W. Superior St.
 Houston 20, Texas 5534 Harvey Wilson Drive
 Indianapolis 22, Ind. 1740 W. Vermont St.
 Johnstown, Pa. 841 Oak St.
 Kansas City 20, Mo. 3525 Gardner Ave.
 Los Angeles 1, Calif. 6900 Stanford Ave.
 Louisville, Ky. 2014 New Main St.
 Midland, Tex. 3404 Bankhead Hwy.
 Milwaukee 3, Wisc. 940 W. St. Paul Ave.
 Minneapolis 12, Minn. 2025 49th Ave., N.
 New Orleans, La. 2815 N. Robertson St.
 New York—N. Bergen, N. J. 6001 Tonnelle Ave.
 Oakland, Calif. 1525 Peralta St.
 *Ontario, Calif. Ont. Int'l Airport
 Philadelphia 24, Pa. 1040 E. Erie Ave.
 Pittsburgh 6, Pa. 6519 Penn Ave.
 Portland 10, Oregon 2727 N.W. 29th Ave.
 Richmond 24, Va. 1403 Ingram Ave.
 Roanoke, Va. 115 Albermarle St.
 Sacramento, Calif. 99 N. 17th St.
 St. Louis 10, Mo. 1115 East Road
 Salt Lake City 4, Utah 301 S. Seventh West St.
 San Francisco 3, Calif. 1098 Harrison St.
 Seattle 4, Wash. 3422 First Ave., S.
 *Seattle 4, Wash. 3422 First Ave., S.
 Southington, Conn. 53 Railroad Ave.
 Spokane 3, Wash. S. 155 Sherman St.
 Tampa 1, Fla. P.O. Box 1245,
 Naval Indus. Res. Shipyard
 Toledo 4, Ohio 1 So. St. Clair St.
 Wheeling, W. Va. 2050 National Rd.
 York, Pa. 54 N. Harrison St.
 Youngstown 7, Ohio 272 E. Indianola Ave.

APPARATUS SALES OFFICES

Abilene, Texas 442 Cedar St.
 Akron 8, Ohio 335 S. Main St.
 Albany 3, N. Y. 8 Colvin Ave.
 Albuquerque, N. Mex. 323 Third St., S.W.
 Alexandria, La. 720 Murray St.
 Allentown, Pa. 1132 Hamilton St.
 Amarillo, Texas Amarillo Bldg.
 Appleton, Wisc. 510 W. College Ave.
 Atlanta 3, Ga. P.O. Box 4659
 1860 Peachtree Rd., N.W.
 Augusta, Ga. Masonic Bldg.
 Augusta, Me. 152 State St.
 Baltimore 1, Md. 111 Park Ave.
 Bangor, Maine P.O. Box 778, 77 Central St.
 Baton Rouge 6, La. 3170 Florida Blvd.
 Battle Creek, Mich. 25 W. Michigan Ave.
 Beaumont, Texas P.O. Box 2870
 1385 Calder Ave.
 Billings, Mont. Rm. 816, 303 No. Broadway
 Binghamton, N. Y. P.O. Box 931
 19 Chenango St.

Birmingham 3, Ala. P.O. Box 2602
 1804 Seventh Ave., N.
 Bismarck, N. Dak. 418 Rosser Ave.
 Bluefield, W. Va. P.O. Box 447, 704 Bland St.
 Appalachian Bldg.
 Boise, Idaho 1524 Idaho St.
 Boston 1, Mass. 140 Federal St.
 Buffalo 2, N. Y. 625 Delaware Ave.
 Butte, Mont. P.O. Box 836, 203 N. Wyoming St.
 Canton 2, Ohio 700 Tuscarawas St., W.
 Cedar Rapids, Iowa 210 Second St., S.E.
 Charleston 28, W. Va. P.O. Box 2313
 306 MacCorkle Ave., S.E.
 Charlotte 1, N. C. P.O. Box 1969
 112 S. Tryon St.
 Chattanooga 2, Tenn. 832 Georgia Ave.
 Chicago 80, Ill. P.O. Box 5970A, 840 S. Canal St.
 Cincinnati 2, Ohio 2621 Victory Pkwy.
 Cleveland 4, Ohio 4966 Woodland Ave.
 Columbia 1, S.C., P.O. Box 1434, 1420 Lady St.
 Columbus 15, Ohio 40 S. Third St.
 Corpus Christi, Texas 205 N. Chaparral
 Dallas 2, Texas 1801 N. Lamar St.
 Davenport—Bettendorf, Ia. P.O. Box 630
 1039 State St.
 Dayton 2, Ohio 11 W. Monument Bldg.
 Dayton 9, Ohio Avia. & Def.,
 2600 Far Hills Ave.
 Denver 2, Colo. P.O. Box 2331
 650 Seventeenth St.
 Des Moines 9, Iowa 505 W. Fifth Ave.
 Detroit 2, Mich. 700 Antoinette St.
 Duluth 2, Minn. 14 W. Superior St.
 Elmira, N. Y. P.O. Box 971
 Main and Woodlawn Aves.
 El Paso, Texas 215 No. Stanton
 Erie 2, Pa. 1001 State St.
 Eugene, Ore. 1170 Pearl St.
 Evansville 19, Ind. P.O. Box 157
 123 N.W. Fourth St.
 Fairmont, W. Va. P.O. Box 1626
 310 Jacobs Bldg.
 Fergus Falls, Minn. P.O. Box 197
 108 N. Court Ave.
 Flint 3, Mich. 653 S. Saginaw St.
 Fort Wayne 6, Ind. 3606 So. Calhoun St.
 Fort Worth 2, Tex. 408 W. Seventh St.
 Fort Worth, Tex. P.O. Box 9218, Avia. & Def.,
 6200 Camp Bowie Blvd.
 Fresno 1, Calif. 407 Patterson Bldg.
 Tulare and Fulton St.
 Grand Rapids 2, Mich. 425 Cherry St., S.E.
 Greensboro, N. C. P.O. Box 1162
 301 S. Elm St.
 Greenville, S. C. P.O. Box 1408
 108 W. Washington St.
 Gulfport, Miss. 207 Jo-Fran Bldg.
 Hagerstown, Md. P.O. Box 477
 Professional Arts Bldg.
 Hartford 5, Conn. 764 Asylum St.
 Houston 1, Texas 1312 Live Oak St.
 Indianapolis 4, Ind. 110 N. Illinois St.
 Jackson, Mich. 120 W. Michigan Ave.
 Jackson 1, Miss. 203 W. Capitol St.
 Jacksonville 2, Fla. Station G—Box 48
 700 E. Union St.
 Johnstown, Pa. 841 Oak St.
 Joplin, Mo. P.O. Box 948, 220 1/2 W. Fourth St.
 Kalamazoo 3, Mich. P.O. Box 447
 114 Parkway Ave.
 Kansas City 6, Mo. 106 W. Fourteenth St.
 Knoxville 16, Tenn. 1301 Hannah Ave.
 Lake Charles, La. P.O. Box 5212
 422 Seventh St.
 Lansing 8, Mich. 814 Michigan National Tower
 Lexington, Ky. First National Bank Bldg.
 Lincoln 8, Neb. Sharpe Bldg., 206 S. 13th St.
 Little Rock, Ark. 103 W. Capitol Ave.
 Los Angeles 54, Calif. 212 N. Vignes St.
 Louisville 2, Ky. 455 S. Fourth St.
 Lubbock, Texas P.O. Box 1464
 3302 Avenue "A"
 Macon, Ga. P.O. Box 1506, 682 Cherry St.
 Madison 3, Wisc. 16 N. Carroll St.

Manchester, N. H. 875 Elm St.
 Medford, Ore., P.O. Box 1349, 107 E. Main St.
 Memphis 3, Tenn. 8 N. Third St.
 Miami 32, Fla. P.O. Box 5062
 25 S.E. Second Ave.
 Midwest City, Okla. P.O. Box 5867
 Avia. & Def., 207 Post Off. Bldg.
 Milwaukee 3, Wisc. 940 W. St. Paul Ave.
 Minneapolis 3, Minn. 12 S. Sixth St.
 Mobile, Ala. 704 Government St.
 Nashville 3, Tenn. 234 Third Ave., N.
 Newark 2, N. J. 744 Broad St.
 New Haven 6, Conn. 129 Church St.
 New Orleans 12, La. 837 Gravier St.
 New York 22, N. Y. 570 Lexington Ave.
 Avia. & Def., Fed. Bldg.,
 International Airport, Jamaica 30, N. Y.
 Niagara Falls, N. Y. 44 Fall St.
 Norfolk 10, Va. 229 W. Bute St.
 Oakland 12, Calif. P.O. Box 1106
 409 Thirteenth St.
 Oklahoma City 2, Okla. 119 N. Robinson St.
 Omaha 2, Nebr. 409 S. Seventeenth St.
 Pasco, Wash. P.O. Box 971, 824 W. Lewis St.
 Peoria 2, Ill. 309 Jefferson Bldg.
 Philadelphia 2, Pa. 3 Penn Center Plaza
 Phoenix, Ariz. P.O. Box 4037, 220 Luhrs Tower
 Pittsburgh 22, Pa. The Oliver Bldg., Mellon Sq.
 Portland 7, Ore. P.O. Box 909
 920 S.W. Sixth Ave.
 Providence 3, R. I. Industrial Trust Bldg.
 Raleigh, N. C. P.O. Box 2507
 16 W. Martin St.
 Reading, Pa. 31 N. Sixth St.
 Richmond 17, Va. P.O. Box 2188
 700 E. Franklin St.
 Riverside, Calif. 3570 Ninth St.
 Roanoke 16, Va. P.O. Box 871
 920 S. Jefferson St.
 Rochester 4, N. Y. 89 E. Ave.
 Rockford, Ill. 110 S. First St.
 Rutland, Vt. 38 1/2 Center St.
 Sacramento 14, Calif. 626 Forum Bldg.
 Saginaw, Mich. Second National Bank Bldg.
 St. Louis 1, Mo. 818 Olive St.
 Salt Lake City 10, Utah P.O. Box 779
 200 S. Main St.
 San Antonio 5, Texas 434 So. Main Ave.
 San Diego 1, Calif. P.O. Box 1222
 1240 Seventh Ave.
 San Francisco 6, Calif. 235 Montgomery St.
 San Jose 10, Calif. 460 Park Ave.
 Savannah, Ga. 40 East Bay St.
 Seattle 4, Wash. P.O. Box 1858
 710 Second Ave.
 Seattle 8, Wash. Avia. & Def., 220 Dawson St.
 Shreveport, La. 206 Beck Bldg.
 Sioux City 13, Iowa 572 Orpheum Electric Bldg.
 South Bend 1, Ind. 112 W. Jefferson Blvd.
 Spokane 4, Wash. S. 162 Post St.
 Springfield, Ill. 607 E. Adams St.
 Springfield 3, Mass. 1387 Main St.
 Stockton, Calif. 11 So. San Joaquin St.
 Syracuse 6, N. Y. P.O. Box 1021
 3532 James St.
 Tacoma 1, Wash. P.O. Box 1485
 1202 Washington Bldg.
 Tampa 6, Fla. P.O. Box 3092, 1206 North A St.
 Toledo 4, Ohio 420 Madison Ave.
 Trenton 8, N. J. 214 E. Hanover St.
 Tucson, Ariz. P.O. Box 710, 650 N. Sixth Ave.
 Tulsa 3, Okla. 320 S. Boston Ave.
 Utica 2, N. Y. 258 Genesee St.
 Washington 5, D. C. 777-14th St., N.W.
 Waterloo, Iowa 206 W. 4th St.
 Wenatchee, Wash. P.O. Box 676
 328 N. Wenatchee Ave.
 Wheeling, W. Va. 40 Fourteenth St.
 Wichita 2, Kan. 200 E. First St.
 Williamston, N. C. P.O. Box 748, 115 E. Main St.
 Worcester 5, Mass. 288 Grove St.
 York, Pa. 56 N. Harrison St.
 Youngstown 5, Ohio 272 E. Indianola Ave.

Hawaii: American Factors, Ltd., P. O. Box 3230, Honolulu 1 Canada: Canadian General Electric Company, Ltd., Toronto

LOCOMOTIVE AND CAR EQUIPMENT DEPARTMENT, GENERAL ELECTRIC COMPANY, ERIE, PA.



RENEWAL PARTS

TYPE GE-733 MOTORS

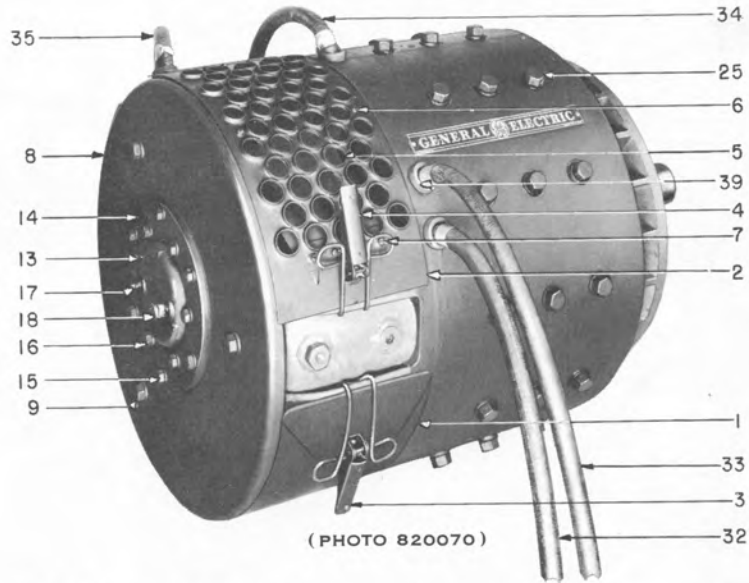

Model no. 5GE733H1 motor with unit exchange assembly

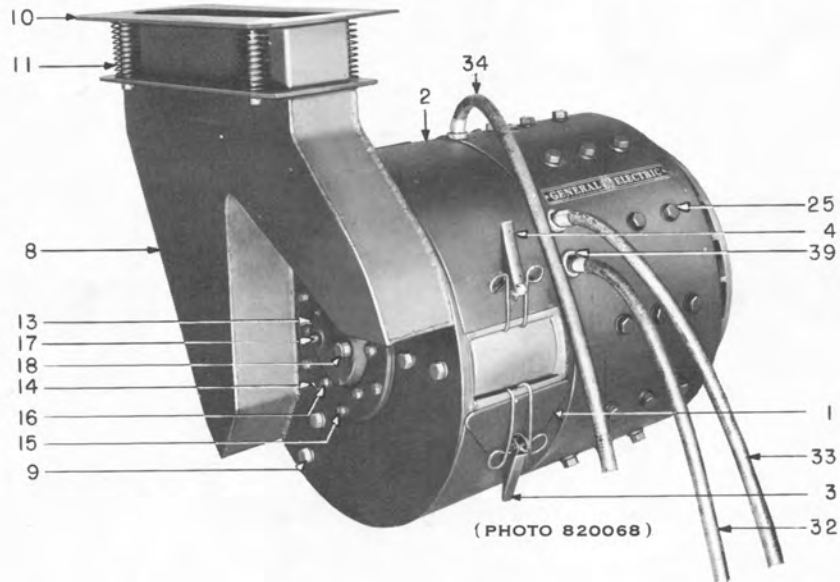

Model no. 5GE733J1 motor with unit exchange assembly

When ordering renewal parts, give quantity, catalog number, description of each item required, and complete nameplate reading.



TYPE GE-733 MOTORS

Model Numbers

5GE733A1	5GE733B1	5GE733C1	5GE733D1	5GE733D5	5GE733H1	5GE733K1
5GE733A2	5GE733B2	5GE733C2	5GE733D2	5GE733D6	5GE733H2	5GE733L1
5GE733A3	5GE733B3	5GE733C3	5GE733D3	5GE733E1	5GE733J1	5GE733N1
5GE733A4	5GE733B4	5GE733C4	5GE733D4	5GE733F1	5GE733J2	5GE733R1

The Type GE-733 Motor and the Type GA-33 Gear Unit were originally identified by the Motor Model Number. The Motor and Gear Unit are now identified by separate Model Numbers. For the convenience of customers, the following table gives a cross reference from original Motor Model Numbers to the present Motor Model Numbers.

Example:- Original Motor Model No. 5GE733A1 is now Model No. 5GE733H1.

Original Motor Model No.	Present Motor Model No.	Original Motor Model No.	Present Motor Model No.	Original Motor Model No.	Present Motor Model No.
5GE733A1	5GE733H1	5GE733B3	5GE733H1	5GE733D1	5GE733H1
5GE733A2	5GE733H1	5GE733B4	5GE733H1	5GE733D2	5GE733H1
5GE733A3	5GE733H1	5GE733C1	5GE733H1	5GE733D3	5GE733H1
5GE733A4	5GE733H1	5GE733C2	5GE733H1	5GE733D4	5GE733H1
5GE733B1	5GE733H1	5GE733C3	5GE733H1	5GE733D5	5GE733H2
5GE733B2	5GE733H1	5GE733C4	5GE733H1	5GE733D6	5GE733H1
				5GE733E1	5GE733J1

Unit Exchange Parts

The Type GE-733-H1 or -J1 Unit Exchange Motors are furnished with the following (shown on Page 6):

Ref. No.	Cat. No.	Number Required	Description
	6799622G11	1	Unit Exchange Assembly with 15-tooth pinion (does not include motor)
	6799622G12	1	Unit Exchange Assembly with 17-tooth pinion (does not include motor)
A	4767988	1	Pinion, 15-teeth, for Cat. No. 6799622G11
A	4767997	1	Pinion, 17-teeth, for Cat. No. 6799622G12
B, E	8864951P49	1	Roller bearing ✓
	6705174	1	Retaining plate for inner race
C	N22P29016B	2	Screw for retaining plate, 1/2 in. -13, 1 in., hex. hd
	6705240	1	Lock washer plate for two 1/2 in. diam screws
D	4729501P1	1	Bearing housing for roller bearing
F	6705172	1	Retaining ring for bearing housing
G	6705224	5	Screw for bearing cap
	2710334	2	Two-way connector for motor leads

Ref. No.	No. Required for Model 5GE733-										Cat. No.	Description
	F1	H1	H2	J1	J2	K1	L1	N1	R1			
1	1	1	1	1	1	1	1	1	-		4748517G1	Large commutator inspection cover, solid, with clamping lever
2	1	-	-	1	1	1	1	1	-		4729816G1	Small commutator inspection cover, solid, with clamping lever
2	-	1	1	-	-	-	-	-	-		6751181G1	Small commutator inspection cover, perforated, with clamping lever and baffle
1	-	-	-	-	-	-	-	-	1		334B325G1	Large commutator inspection cover, with locking device
3	1	1	1	1	1	1	1	1	-		4757708	Clamping lever with spring link, for Cat. No. 4748517G1
4	1	1	1	1	1	1	1	1	-		4757800	Clamping lever with spring link, for Cat. No. 4729816G1 or 6751181G1
	-	-	-	-	-	-	-	-	1		2735802P1	Handle for locking device
	-	-	-	-	-	-	-	-	1		186V924P1	Eyebolt for locking device
	2	2	2	2	2	2	2	2	-		N312P1816	Hinge rivet for clamping lever, 3/16 in. dia. by 1 in. butt. hd.
5	-	1	1	-	-	-	-	-	-		4729726G1	Baffle for Cat. No. 6751181G1
	-	4	4	-	-	-	-	-	-		6705825P1	Guide for baffle

TYPE GE-733 MOTORS

GEF-3265D

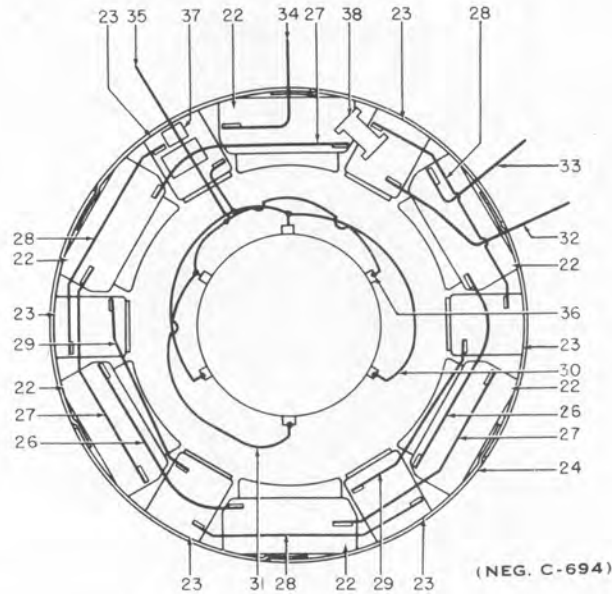

Field coils and connections

Ref. No.	No. Required for Model 5GE733-										Cat. No.	Description
	F1	H1	H2	J1	J2	K1	L1	N1	R1			
6	-	2	2	-	-	-	-	-	-	-	N44P16006B	Screw fastening baffle to cover, 10-32, 3/8 in., fil. hd.
7	-	8	8	-	-	-	-	-	-	-	N44P16008B	Screw fastening baffle and guide to cover, 10-32, 1/2 in., fil. hd.
	-	10	10	-	-	-	-	-	-	-	N218P16B	Nut, 10-32 sq.
	-	10	10	-	-	-	-	-	-	-	N405P39	Lock washer, No. 10
8	1	-	-	-	-	-	-	-	-	-	6733124P1	End cover, perforated
8	-	1	1	-	-	-	-	-	-	-	6705215	End cover, solid
8	-	-	-	1	1	-	-	-	-	-	4748687G1	End cover with air duct
8	-	-	-	-	-	1	-	-	-	-	6746287G1	End cover with air duct
8	-	-	-	-	-	-	1	-	-	-	481A212P1	End cover, solid
8	-	-	-	-	-	-	-	-	1	-	4748687G2	End cover with air duct
	-	-	-	-	-	-	-	-	1	-	6733175P1	Support for commutator inspection covers
9	3	3	3	-	-	-	-	-	3	-	N22P29018B	Bolt fastening end cover or cover support to magnet frame, 1/2 in. -13, 1 1/8 in. hex. hd.
9	-	-	-	6	6	6	6	-	6	-	N22P29016B	Bolt fastening end cover to magnet frame, 1/2 in. -13, 1 in. hex. hd.
	3	3	3	6	6	6	6	3	6	-	N405P45	Lock washer, 1/2 in.
10	-	-	-	1	1	1	-	-	1	-	4748686G1	Air duct with guide pins
11	-	-	-	4	4	4	-	-	4	-	4763969	Compression spring for air duct
	-	-	-	4	4	4	-	-	4	-	6718580P1	Washer for air duct guide pin
	-	-	-	4	4	4	-	-	4	-	N503P2220B	Cotter pin, 1/4 in. dia. by 1 1/4 in.
12	1	1	1	1	1	1	1	1	1	-	4729520P1	Bearing housing, commutator end
13	1	1	1	1	1	1	1	1	-	-	4729530P3	Bearing cap, not drilled for lubricant fittings, commutator end
13	1	1	1	1	1	1	1	1	1	-	4729530P1	Bearing cap, drilled for lubricant fittings, commutator end
14	1	1	1	1	1	1	1	1	1	-	6726076P1	End plate for bearing cap and housing
	1	1	1	1	1	1	1	1	1	-	8806964P1	Gasket between bearing cap and housing
	2	2	2	2	2	2	2	2	2	-	N51P23016B	Bolt fastening bearing cap to housing, 5/16 in. -18, 1 in., fl. hd.
15	6	6	6	6	6	6	6	6	6	-	N22P25020B	Bolt fastening end plate to magnet frame, 3/8 in. -16, 1 1/4 in., hex. hd.
16	6	6	6	6	6	6	6	6	6	-	N22P25028B	Bolt fastening end plate and bearing cap to bearing housing, 3/8 in. -16, 1 3/4 in., hex. hd.
17	12	12	12	12	12	12	12	12	12	-	N405P43	Lock washer, 3/8 in.
	1	1	-	1	1	1	1	1	1	-	87X734	Lubricant fitting for bearing cap (Alemite Div., Stewart Warner Corp., Cat. No. 1612)

TYPE GE-733 MOTORS

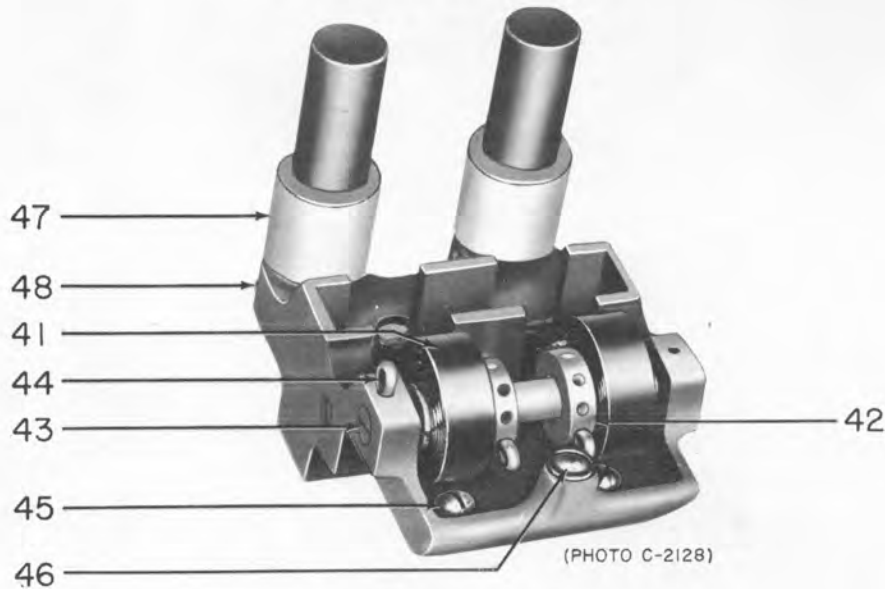

Brush holder, ref. no. 40

Ref. No.	No. Required for Model 5GE733-									Cat. No.	Description
	F1	H1	H2	J1	J2	K1	L1	N1	R1		
17	-	-	1	-	-	-	-	-	-	101X128	Lubricant fitting for bearing cap (Alemite Div., Stewart Warner Corp., Cat. No. A393)
18	1	1	1	1	1	1	1	1	1	10X605	Lubricant overflow relief device (Gits Bros. Mfg. Co., Style "O", No. 211)
19	1	1	1	1	1	1	1	1	1	8864950P121	Ball bearing, commutator end
20	1	1	1	1	1	1	1	1	1	8806981P1	Lubricant flinger back of ball bearing
21	1	1	1	1	1	1	1	1	1	2348969	Retaining nut for ball bearing
	1	1	1	1	1	1	1	1	1	2348970	Lock washer for retaining nut
22	6	6	6	6	6	6	6	6	6	4748332G3	Exciting field coil with pole piece
23	6	6	6	6	-	6	-	6	6	4748337G3	Commutating field coil with pole piece
23	-	-	-	-	6	-	6	-	-	8843543G1	Commutating field coil with pole piece
24	6	6	6	6	6	6	6	6	6	6705192	Pad under field coils
25	36	36	36	36	36	36	36	36	36	N22P33040	Bolt fastening pole piece to magnet frame, 5/8 in. -11, 2 1/2 in., hex. hd.
	36	36	36	36	36	36	36	36	36	N405P47	Lock washer, 5/8 in.
26	2	2	2	2	2	2	2	2	2	4748599G2	Insulated connection strap for exciting field coil
27	3	3	3	3	3	3	3	3	3	4748599G3	Insulated connection strap for exciting field coil
28	3	3	3	3	3	3	3	3	3	4748599G1	Insulated connection strap for commutating field coil
29	2	2	2	2	2	2	2	2	2	4748599G4	Insulated connection strap for commutating field coil
30	1	1	1	1	1	1	1	1	1	4748596G1	Insulated bus ring with field coil connector, for brush holder
31	1	1	1	1	1	1	1	1	1	4748596G2	Insulated bus ring with lead connection, for brush holder
32	1	1	-	1	1	1	1	1	1	6744148G1	Lead cable with swaged terminals for commutating field coil, top right-hand
32	-	-	1	-	-	-	-	-	-	6744148G7	Lead cable with swaged terminals for commutating field coil, top right-hand
33	1	1	-	1	1	1	1	1	1	6744148G4	Lead cable with swaged terminals for exciting field coil, upper right-hand
33	-	-	1	-	-	-	-	-	-	6744148G10	Lead cable with swaged terminals, for exciting field coil, upper right-hand
34	1	1	-	1	1	1	1	1	1	6744148G2	Lead cable with swaged terminals, for exciting field coil, top
34	-	-	1	-	-	-	-	-	-	6744148G8	Lead cable with swaged terminals, for exciting field coil, top

TYPE GE-733 MOTORS

GEF-3265D

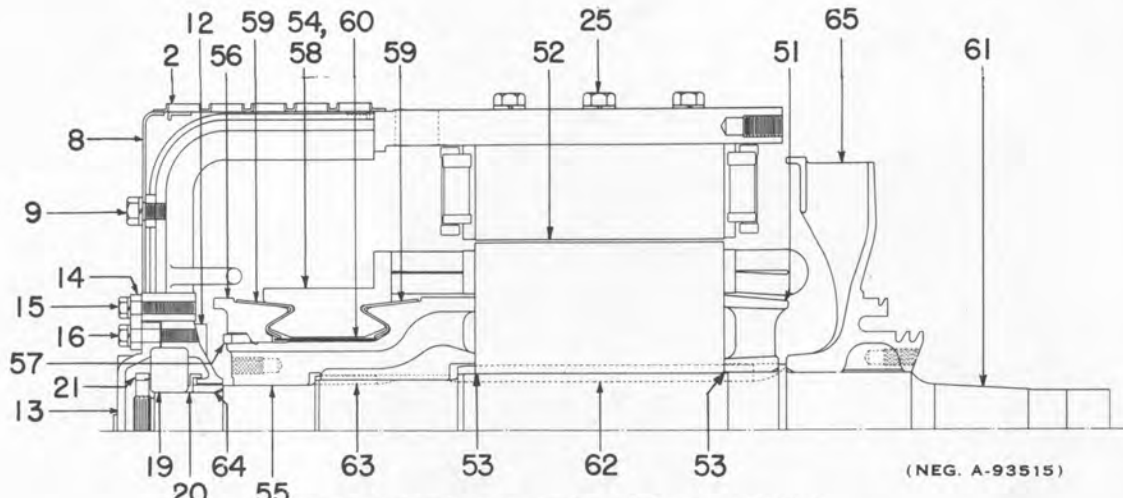

Longitudinal section of model no. 5GE733H1

Ref. No.	No. Required for Model 5GE733-									Cat. No.	Description
	F1	H1	H2	J1	J2	K1	L1	N1	R1		
35	1	1	-	1	1	1	1	1	1	6744148G3	Lead cable with swaged terminals for bus ring
35	-	-	1	-	-	-	-	-	-	6744148G9	Lead cable with swaged terminals for bus ring
	4	4	4	4	4	4	4	4	4	101X146	Solderless terminal for lead cable (Thomas and Betts Co. Cat. No. MD550)
	24	24	24	24	24	24	24	24	24	N22P21010B	Bolt fastening connection strap or lead cable to field coil, 1/4 in. -20, 5/8 in. hex. hd.
36	6	6	6	6	6	6	6	6	6	N22P23012B	Bolt fastening bus ring to brush holder, 5/16 in. -18, 3/4 in. hex. hd.
	1	1	1	1	1	1	1	1	1	N22P23010B	Bolt fastening lead cable to bus ring, 5/16 in. -18, 5/8 in. hex. hd.
	24	24	24	24	24	24	24	24	24	N203P21B	Nut, 1/4 in. -20, hex.
	1	1	1	1	1	1	1	1	1	N203P23B	Nut, 5/16 in. -18, hex.
	24	24	24	24	24	24	24	24	24	N405P41	Lock washer, 1/4 in.
	7	7	7	7	7	7	7	7	7	N405P42	Lock washer, 5/16 in.
	1	1	1	-	-	-	-	1	-	6732809P1	Clamping block for bus ring lead (casting)
	-	-	-	1	1	1	1	-	1	6705878P1	Clamping block for bus ring lead
37	1	1	1	1	1	1	1	1	1	6705313	Cable clamp for bus ring lead
	1	1	1	-	-	-	-	1	-	6705196	Insulation shield between clamping block and cable
	2	2	2	-	-	-	-	2	-	N22P25040B	Bolt fastening cable clamp to magnet frame, 3/8 in. -16, 2 1/2 in. hex. hd.
	-	-	-	2	2	2	2	-	2	N22P25048B	Bolt fastening cable clamp to magnet frame, 3/8 in. -16, 3 in. hex. hd.
	2	2	2	2	2	2	2	2	2	N203P25B	Nut, 3/8 in. -16, hex.
	1	1	1	1	1	1	1	1	1	2714178	Plate washer for two 3/8 in. bolts
	4	4	4	4	4	4	4	4	4	N405P43	Lock washer, 3/8 in.
38	1	1	1	1	1	1	1	1	1	6705988P1	Fiber spacing block between field coils
39	4	4	4	4	4	4	4	4	4	2363429	Soft rubber bushing for cable
	<p>NOTE: Filler used around terminals is No. 2 black Putty. Glass Tape used to insulate terminals or tie connectors is 0.005 in. by 1 in. A2L7B. Glass tape must be treated by customer before applying. Advice for treating will be furnished on request. Varnish used over tape is No. 2450. All are G-E Materials.</p>										
40	6	6	6	6	6	6	6	6	6	9949750G2	Brush holder with pressure arms and insulated studs

TYPE GE-733 MOTORS

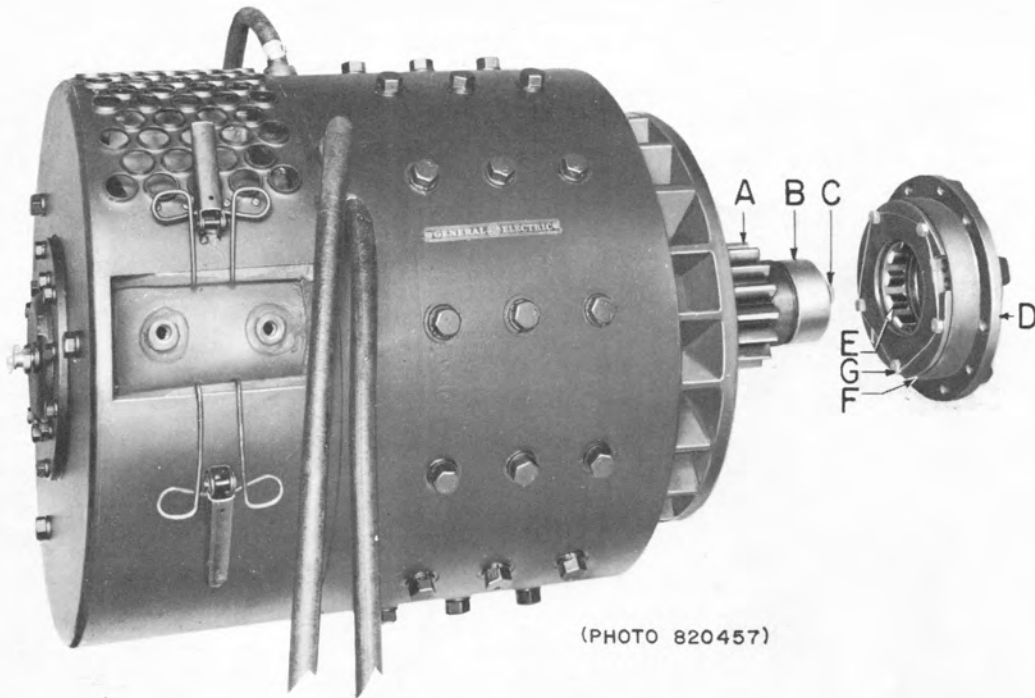

(PHOTO 820457)

Model no. 5GE733H1 motor with unit exchange assembly

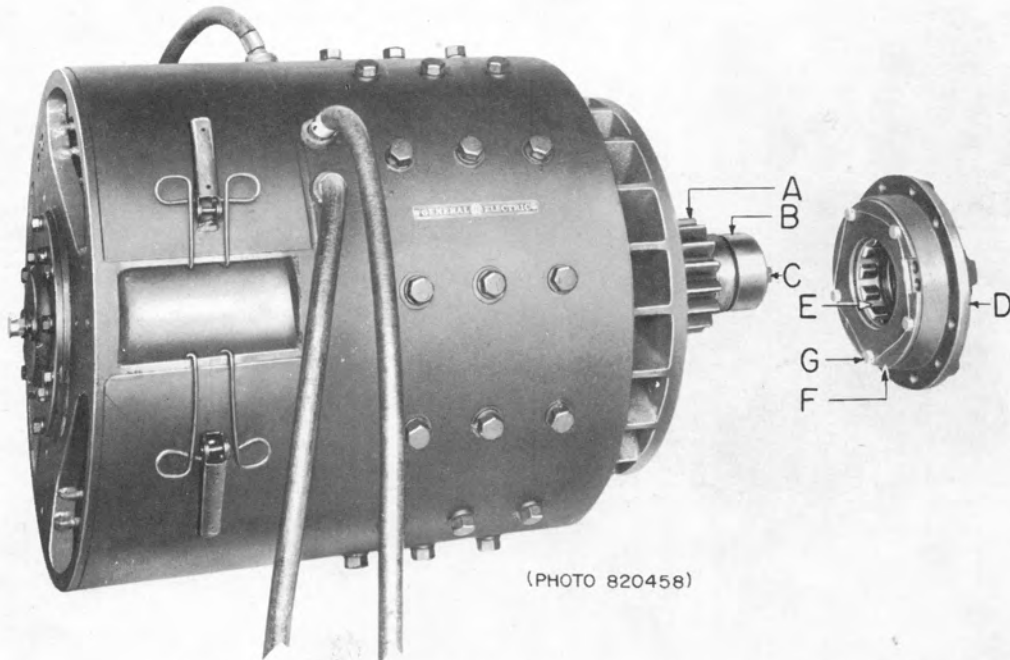

(PHOTO 820458)

Model no. 5GE733J1 motor with unit exchange assembly

TYPE GE-733 MOTORS

GEF-3265D

Ref. No.	No. Required for Model 5GE733-									Cat. No.	Description
	F1	H1	H2	J1	J2	K1	L1	N1	R1		
	6	-	-	6	6	-	-	-	-	6705717G1	†Pressure arm with tip and shunt, right-hand facing front of brush holder (3/8 in. wide)
	6	-	-	6	6	-	-	-	-	6705717G2	†Pressure arm with tip and shunt, left-hand facing front of brush holder (3/8 in. wide)
41	12	12	12	12	12	12	12	12	12	6705717G4	Pressure arm with tip and shunt
	12	12	12	12	12	12	12	12	-	6718628P1	†Adjusting sleeve for pressure arm (13/16 in. long)
42	12	12	12	12	12	12	12	12	1/2	8805248P1	Adjusting sleeve for pressure arm (7/8 in. long)
	6	-	-	6	6	-	-	-	-	6705765P1	†Hinge pin for pressure arm (2 9/16 in. long)
	6	6	6	6	6	6	6	6	-	6718629P1	†Hinge pin for pressure arm (2 3/4 in. long)
43	6	6	6	6	6	6	6	6	6	186V578	Hinge pin for pressure arm (3 1/4 in. long)
	12	-	-	12	12	-	-	-	-	6705724P1	†Large washer for hinge pin
	12	-	-	12	12	-	-	-	-	6705723P1	†Small washer for hinge pin
44	18	18	18	18	18	18	18	18	18	N503P1216B	Cotter pin for adjusting sleeve and hinge pin, 1/8 in. dia. by 1 in.
	6	6	6	6	6	6	6	6	-	6726411G1	†Support for pressure arms
	18	18	18	18	18	18	18	18	-	227X13	†Rivet for support, 3/16 in. dia. by 1/2 in. truss. hd.
45	12	12	12	12	12	12	12	12	12	N37P16005B	Screw fastening pressure arm shunt to brush holder body, 10-32, 5/16 in., rd. hd.
	12	12	12	12	12	12	12	12	12	N405P39	Lock washer, No. 10
46	6	6	6	6	6	6	6	6	6	2088042	Binding screw for brush pigtails
47	12	12	12	12	12	12	12	12	12	493A590G1	§Insulated stud for brush holder
48	12	12	12	12	12	12	12	12	12	489763	Pin for stud and body
	12	12	12	12	12	12	12	12	-	450736	§Porcelain insulator (for original design stud)
50	12	12	12	12	12	12	12	12	-	6727577	◇Carbon brush with pigtail and terminal
	-	-	-	-	-	-	-	-	6	9961431	◇Carbon brush with pigtail and terminal
	6	6	6	6	6	6	6	6	6	4729516G1	Flash over baffle for brush holder
	6	6	6	6	6	6	6	6	6	6705218	Clamp for brush holder studs, with locating holes
	6	6	6	6	6	6	6	6	6	4732723P2	Clamp for brush holder studs, without locating holes
	6	6	6	6	6	6	6	6	6	N22P27032B	Bolt fastening brush holder clamps to magnet frame, 7/16 in. -14, 2 in., hex. hd.
	6	6	6	6	6	6	6	6	6	N405P44	Lock washer, 7/16 in.
	1	1	1	1	1	1	-	1	1	6751173G1	Armature with commutator, shaft and fan
	-	-	-	-	-	-	1	-	-	6751173G3	Armature with commutator, shaft and gear box seal
	1	1	1	1	1	1	1	1	1	4748335G5	Armature rewinding kit consisting of: armature coils, filler pieces, and set of armature rewinding insulations
	1	1	1	1	1	1	1	1	1	4748335G4	Set of armature binding insulations with clips

† Two designs of pressure arms have been furnished for Type GE-733 Motors. The first design, used only on Models 5GE733F1, -H1, and -H2, had separate right and left pressure arms, 3/8 in. wide, and required no adjusting sleeves. The present design has pressure arms, 1/2 in. wide with adjusting sleeves, 7/8 in. long. The complete brush-holder assembly, Cat. No. 9949750G2, is interchangeable with the original design; however, the pressure arms, adjusting sleeves, and hinge pins are not. Therefore when ordering renewal parts, extreme care must be taken to determine correct catalog numbers.

§ Two designs of insulated studs have been furnished for Type GE-733 Motors. The original design, consisting of stud, clamping sleeve and separate porcelain insulator, is no longer available. The current design, consisting of stud with moulded plastic insulation and sleeve, is interchangeable with the original design and is now furnished for all renewal parts. Porcelain insulation for original design of stud can still be furnished when requested.

◇ When ordering, be sure to give complete nameplate designation of device for which carbon brush is required. Recommended grade of carbon brush for device as shown in this bulletin will be furnished, unless otherwise specified.

TYPE GE-733 MOTORS

Ref. No.	No. Required for Model 5GE733-										Cat. No.	Description
	F1	H1	H2	J1	J2	K1	L1	N1	R1			
												NOTE: Binder cord used over commutator mica is G-E Material A4A3B6. Varnish Sealer over mica cord is G-E Material A15B17A. Binding wire used for end bands is 0.072 in. dia. G-E Material B4Y2 requiring approximately 125 feet (1 3/4 lbs)
51	1	1	1	1	1	1	1	1	1	1	4729419P1	Armature head, fan end
	1	1	1	1	1	1	1	1	1	1	107X34	Set of armature punchings
52	310	310	310	310	310	310	310	310	310	310	4729498G1	Main punching (0.025 in. thick)
53	4	4	4	4	4	4	4	4	4	4	4729498G2	End punching (0.064 in. thick)
54	1	1	1	1	1	1	1	1	1	1	4729499G4	Commutator (seasoned)
54	1	1	1	1	1	1	1	1	1	1	4729499G3	‡Commutator (unseasoned)
55	1	1	1	1	1	1	1	1	1	1	4729491P1	Shell for commutator
56	1	1	1	1	1	1	1	1	1	1	6726041P1	Cap for commutator
57	1	1	1	1	1	1	1	1	1	1	6717930P1	Clamping nut for commutator
58	1	1	1	1	1	1	1	1	1	1	4729499P8	‡Set of copper and mica segments, finished and bound (Must be seasoned after assembly.)
59	2	2	2	2	2	2	2	2	2	2	6717932P1	Combination inner and outer mica cone, for front or back of commutator
60	1	1	1	1	1	1	1	1	1	1	4729499P7	Mica collar under segments
61	1	1	1	1	1	1	1	1	1	1	4748327G1	Armature shaft with keys for punchings and commutator
62	1	1	1	1	1	1	1	1	1	1	8806966P1	Key for punchings and shaft
63	1	1	1	1	1	1	1	1	1	1	4705714	Key for commutator and shaft
64	1	1	1	1	1	1	1	1	1	1	8806988P1	Spacing collar back of ball bearing, commutator end
65	1	1	1	1	1	1	-	1	1	1	4748326P1	Fan for armature
	-	-	-	-	-	-	1	-	-	-	481A211P1	Gear box seal for armature shaft, pinion end
	1	1	1	1	1	1	1	1	1	1	2766829AAP2	†Balancing weight, commutator end
	1	1	1	1	1	1	-	1	1	1	2766829ADP29	†Balancing weight, fan end, (1/4 in. thick)
	Δ	Δ	Δ	Δ	Δ	Δ	-	Δ	Δ	Δ	2766829ABP4	Balancing weight, fan end, (1/8 in. thick)
	Δ	Δ	Δ	Δ	Δ	Δ	-	Δ	Δ	Δ	2766829ABP5	Balancing weight, fan end, (1/16 in. thick)
	-	-	-	-	-	-	1	-	-	-	8811463	†Balancing weight, pinion end
	Δ	Δ	Δ	Δ	Δ	Δ	-	Δ	Δ	Δ	N312P1812	Rivet for balancing weight, 3/16 in. dia. by 3/4 in., butt. hd.
	F1	H1	H2	J1	J2	K1	L1	N1	R1			

‡ Customers not having commutator seasoning equipment should not order an unseasoned commutator nor a set of commutator segments. If customer has commutator seasoning equipment, advice for seasoning will be furnished on request.

† Balancing weights are furnished in complete rings to be cut to suit when balancing armature. Each ring contains sufficient material to balance approximately three armatures.

Δ Quantity variable.

INDEX OF CATALOG NUMBERS

Catalog identifications in this index are arranged in order, reading from *left to right*, first alphabetically according to the prefix letter or letters, if used, and second numerically.

In this index all numbers with a letter prefix will precede those without prefixes.

The number of letters or digits does not affect placement in the table, thus A1999999 will precede A2, and ZZ9999999 will precede Cat. No. 1 (number without a prefix). Letters take precedence over numbers so that Cat. No. 26F1 will precede Cat. No. 261.

Cat. No.	Page	Cat. No.	Page	Cat. No.	Page	Cat. No.	Page
N203P21B-----	5	227X13 -----	7	4748596G2 ----	4	6718580P1 ----	3
N203P23B-----	5	2348969-----	4	4748599G1 ----	4	6718628P1 ----	7
N203P25B-----	5	2348970-----	4	4748599G2 ----	4	6718629P1 ----	7
N218P16B-----	3	2363429-----	5	4748599G3 ----	4	6726041P1 ----	8
N22P21010B----	5	2710334-----	2	4748599G4 ----	4	6726076P1 ----	3
N22P23010B----	5	2714178-----	5	4748686G1 ----	3	6726411G1 ----	7
N22P23012B----	5	2735802P1 ----	2	4748687G1 ----	3	6727577-----	7
N22P25020B----	3	2766829AAP2--	8	4748687G2 ----	3	6732809P1 ----	5
N22P25028B----	3	2766829ABP4--	8	4757708-----	2	6733124P1 ----	3
N22P25040B----	5	2766829ABP5--	8	4757800-----	2	6733175P1 ----	3
N22P25048B----	5	2766829ADP29-	8	4763969-----	3	6744148G1 ----	4
N22P27032B----	7	334B325G1 ----	2	4767988-----	2	6744148G3 ----	5
N22P29016B----	2,3	4705714-----	8	4767997-----	2	6744148G4 ----	4
N22P29018B----	3	4729419P1 ----	8	481A211P1 ----	8	6744148G7 ----	4
N22P33040 ----	4	4729491P1 ----	8	481A212P1 ----	3	6744148G10 ---	4
N312P1812 ----	8	4729498G2 ----	8	489763-----	7	6744148G2 ----	4
N312P1816 ----	2	4729498G1 ----	8	493A590G1 ----	7	6744148G8 ----	4
N37P16005B----	7	4729499G3 ----	8	6705172-----	2	6744148G9 ----	5
N405P39 -----	3,7	4729499G4 ----	8	6705174-----	2	6746287G1 ----	3
N405P41 -----	5	4729499P7 ----	8	6705192-----	4	6751173G1 ----	7
N405P42 -----	5	4729499P8 ----	8	6705196-----	5	6751173G3 ----	7
N405P43 -----	3,5	4729501P1 ----	2	6705215-----	3	6751181G1 ----	2
N405P44 -----	7	4729516G1 ----	7	6705218-----	7	6799622G11 ---	2
N405P45 -----	3	4729520P1 ----	3	6705224-----	2	6799622G12 ---	2
N405P47 -----	4	4729530P1 ----	3	6705240-----	2	87X734 -----	3
N44P16006B----	3	4729530P3 ----	3	6705313-----	5	8805248P1 ----	7
N44P16008B----	3	4729726G1 ----	2	6705717G1 ----	7	8806964P1 ----	3
N503P1216B----	7	4729816G1 ----	2	6705717G2 ----	7	8806966P1 ----	8
N503P2220B----	3	4732723P2 ----	7	6705717G4 ----	7	8806981P1 ----	4
N51P23016B----	3	4748326P1 ----	8	6705723P1 ----	7	8806988P1 ----	8
10X605 -----	4	4748327G1 ----	8	6705724P1 ----	7	8811463-----	8
101X128 -----	4	4748332G3 ----	4	6705765P1 ----	7	8843543G1 ----	4
101X146 -----	5	4748335G4 ----	7	6705825P1 ----	2	8864950P121 --	4
107X34 -----	8	4748335G5 ----	7	6705878P1 ----	5	8864951P49 ---	2
186V578 -----	7	4748337G3 ----	4	6705988P1 ----	5	9949750G2 ----	5,7
186V924P1 ----	2	4748517G1 ----	2	6717930P1 ----	8	9961431-----	7
2088042-----	7	4748596G1 ----	4	6717932P1 ----	8		

WHEN YOU NEED SERVICE

IF YOU NEED TO REPAIR, recondition, or rebuild any electric apparatus, a G-E service shop near you is available day and night, seven days a week, for work in the shops or on your premises. Latest factory methods and genuine G-E renewal parts are used to maintain the original performance of your G-E equipment. For full information about these services, contact the nearest service shop or sales office listed below:

APPARATUS SERVICE SHOPS

Allentown, Pa. 672-676 E. Highland St.
 Appleton, Wisc. Midway Industrial Area,
 County Trunk, "P"
 Atlanta—Chamblee, Ga. 4639 Peachtree
 Indus. Blvd.
 Baltimore 30, Md. 920 E. Fort Ave.
 Boston—Medford 55, Mass. Mystic Valley Pkwy.
 Buffalo 11, N. Y. 318 Urban St.
 Charleston 28, W. Va. 306 MacCorkle Ave., S.E.
 Charlotte, N. C. 2328 Thrift Road
 Chicago 32, Ill. 4360 W. 47th St.
 Cincinnati 2, Ohio 444 W. Third St.
 Cleveland 4, Ohio 4966 Woodland Ave.
 Columbus 23, Ohio 2128 Eakin Rd.
 Corpus Christi, Texas 115 Busse St.
 Dallas 19, Texas 3202 Manor Way
 Davenport—Bettendorf, Ia. 1039 State St.
 Decatur, Ill. 2225 E. Logan St.
 Denver 5, Colo. 3353 Larimer St.
 Detroit 2, Mich. 5950 Third Ave.
 Houston 20, Texas 5534 Harvey Wilson Drive
 Indianapolis 22, Ind. 1740 W. Vermont St.
 Johnstown, Pa. 841 Oak St.
 Kansas City, Mo. 3525 Gardner Ave.
 Los Angeles 1, Calif. 6900 Stanford Ave.
 Louisville, Ky. 2014 New Main St.
 Midland, Tex. 3404 Bankhead Hwy.
 Milwaukee 3, Wisc. 940 W. St. Paul Ave.
 Minneapolis 12, Minn. 2025 49th Ave., N.
 New Orleans, La. 2815 N. Robertson St.
 New York—N. Bergen, N.J. 6001 Tannelle Ave.
 Oakland, Calif. 1525 Peralta St.
 Philadelphia 24, Pa. 1040 E. Erie Ave.
 Pittsburgh 6, Pa. 6519 Penn Ave.
 Portland 10, Oregon 2727 N.W. 29th Ave.
 Richmond 24, Va. 1403 Ingram Ave.
 Roanoke, Va. 115 Albermarle St.
 Sacramento, Calif. 99 N. 17th St.
 St. Louis 10, Mo. 1115 East Road
 Salt Lake City 4, Utah. 301 S. Seventh West St.
 San Francisco 3, Calif. 1098 Harrison St.
 Seattle 4, Wash. 3422 First Ave., S.
 Southington, Conn. 53 Railroad Ave.
 Spokane 3, Wash. S. 155 Sherman St.
 Tampa 1, Fla. P.O. Box 1245,
 Naval Indus. Res. Shipyard
 Toledo 4, Ohio 1 So. St. Clair St.
 Wheeling, W. Va. 2050 National Rd.
 York, Pa. 54 N. Harrison St.
 Youngstown 5, Ohio 272 E. Indianola Ave.

APPARATUS SALES OFFICES

Abilene, Texas 442 Cedar St.
 Akron 8, Ohio 335 S. Main St.
 Albany 7, N. Y. 90 State St.
 Albuquerque, N. Mex. 323 Third St., S.W.
 Alexandria, La. 720 Murray St.
 Allentown, Pa. 1132 Hamilton St.
 Amarillo, Texas Amarillo Bldg.
 Appleton, Wisc. 531 W. College Ave.
 Atlanta 3, Ga. 1860 Peachtree Rd., N.W.
 Augusta, Ga. Masonic Bldg.
 Augusta, Me. 152 State St.
 Baltimore 1, Md. 111 Park Ave.
 Bangor, Maine 77 Central St.
 Baton Rouge 6, La. 3170 Florida Blvd.
 Battle Creek, Mich. 25 W. Michigan Ave.
 Beaumont, Texas 1385 Calder Ave.
 Billings, Mont. Rm. 816, 303 No. Broadway
 Binghamton, N. Y. 19 Chenango St.

Birmingham 3, Ala. 1804 Seventh Ave., N.
 Bismarck, N. Dak. 418 Rosser Ave.
 Bluefield, W. Va. 704 Bland St.
 Appalachian Bldg.
 Boise, Idaho 1524 Idaho St.
 Boston 1, Mass. 140 Federal St.
 Buffalo 3, N. Y. 535 Washington St.
 Butte, Mont. P.O. Box 836, 103 N. Wyoming St.
 Canton 2, Ohio 700 Tuscarawas St., W.
 Cedar Rapids, Iowa 210 Second St., S.E.
 Charleston 28, W. Va. 306 MacCorkle Ave., S.E.
 Charlotte 1, N. C. 112 S. Tryon St.
 Chattanooga 2, Tenn. 832 Georgia Ave.
 Chicago 80, Ill. P.O. Box 5970A, 840 S. Canal St.
 Cincinnati 2, Ohio 215 W. Third St.
 Cleveland 4, Ohio 4966 Woodland Ave.
 Columbia 1, S.C., P.O. Box 1434, 1420 Lady St.
 Columbus 15, Ohio 40 S. Third St.
 Corpus Christi, Texas 205 N. Chaparral
 Dallas 2, Texas 1801 N. Lamar St.
 Davenport—Bettendorf, Ia. 1039 State St.
 Dayton 2, Ohio 11 W. Monument Bldg.
 Dayton 9, Ohio. Avia. & Def.,
 2600 Far Hills Ave.
 Denver 2, Colo. 650 Seventeenth St.
 Des Moines 9, Iowa 505 W. Fifth Ave.
 Detroit 2, Mich. 700 Antoinette St.
 Duluth 2, Minn. 14 W. Superior St.
 Elmira, N. Y. Main and Woodlawn Aves.
 El Paso, Texas 215 No. Stanton
 Erie, Pa. 1001 State St.
 Eugene, Ore. Cascade Bldg., 1170 Pearl St.
 Evansville 19, Ind. 123 N.W. Fourth St.
 Fairmont, W. Va. 310 Jacobs Bldg.,
 P.O. Box 1626
 Fergus Falls, Minn. 108 N. Court Ave. P.O. Box 197
 Flint 3, Mich. 653 S. Saginaw St.
 Fort Wayne 6, Ind. 3606 So. Calhoun St.
 Fort Worth 2, Tex. 408 W. Seventh St.
 Fort Worth, Tex. Avia. & Def.,
 6200 Camp Bowie Blvd.
 Fresno 1, Calif. 407 Patterson Bldg.
 Tulare and Fulton St.
 Grand Rapids 2, Mich. 425 Cherry St., SE
 Greensboro, N. C. 301 S. Elm St.
 Greenville, S. C. 108 W. Washington St.
 Gulfport, Miss. 207 Jo-Fran Bldg.
 Hagerstown, Md. Professional Arts Bldg.
 Hartford 5, Conn. 764 Asylum Ave.
 Houston 1, Texas 1312 Live Oak St.
 Indianapolis 4, Ind. 110 N. Illinois St.
 Jackson, Mich. 120 W. Michigan Ave.
 Jackson 1, Miss. 203 W. Capitol St.
 Jacksonville 2, Fla. 700 E. Union St.
 Jamestown, N. Y. P.O. Box 548, 2 Second St.
 Johnstown, Pa. 841 Oak St.
 Joplin, Mo. P.O. Box 948, 220 1/2 W. Fourth St.
 Kalamazoo 3, Mich. 112 Parkway Ave.
 Kansas City 6, Mo. 106 W. Fourteenth St.
 Knoxville 16, Tenn. 1301 Hannah Ave.
 Lake Charles, La. 422 Seventh St.
 Lansing 8, Mich. 306 Michigan National Tower
 Lexington, Ky. First National Bank Bldg.
 Lincoln 8, Nebr. Sharpe Bldg., 206 S. 13th St.
 Little Rock, Ark. 103 W. Capitol Ave.
 Los Angeles 54, Calif. 212 N. Vignes St.
 Louisville 2, Ky. 455 S. Fourth St.
 Lubbock, Texas 3302 Avenue "A"
 Macon, Ga. 682 Cherry St.
 Madison 3, Wisc. 16 N. Carroll St.
 Manchester, N. H. 875 Elm St.

Medford, Ore., P.O. Box 1349, 107 E. Main St.
 Memphis 3, Tenn. 8 N. Third St.
 Miami 32, Fla. 25 S.E. Second Ave.
 Midwest City, Okla. Avia. & Def.,
 207 Post Off. Bldg.
 Milwaukee 3, Wisc. 940 W. St. Paul Ave.
 Minneapolis 3, Minn. 12 S. Sixth St.
 Mobile 13, Ala. 54 St. Joseph St.
 Nashville 3, Tenn. 234 Third Ave., N.
 Newark 2, N. J. 744 Broad St.
 New Haven 6, Conn. 129 Church St.
 New Orleans 12, La. 837 Gravier St.
 New York 22, N. Y. 570 Lexington Ave.
 New York Avia. & Def., Fed. Bldg.,
 N. Y. International Airport, Jamaica 30, N. Y.
 Niagara Falls, N. Y. 253 Second St.
 Norfolk 10, Va. 229 W. Bute St.
 Oakland 12, Calif. 409 Thirteenth St.
 Oklahoma City 2, Okla. 119 N. Robinson St.
 Omaha 2, Nebr. 409 S. Seventeenth St.
 Pasco, Wash. 824 W. Lewis St.
 Peoria 2, Ill. 309 Jefferson Bldg.
 Philadelphia 2, Pa. 1405 Locust St.
 Phoenix, Ariz. P.O. Box 4037, 303 Luhrs Tower
 Pittsburgh 22, Pa. The Oliver Bldg., Mellon Sq.
 Portland 7, Ore. 920 S.W. Sixth Ave.
 Providence 3, R. I. Industrial Trust Bldg.
 Raleigh, N. C. Room 401, 16 W. Martin St.
 Reading, Pa. 31 N. Sixth St.
 Richmond 17, Va. 700 E. Franklin St.
 Riverside, Calif. 3570 Ninth St.
 Roanoke 16, Va. 920 S. Jefferson St.
 Rochester 4, N. Y. 89 E. Ave.
 Rockford, Ill. 110 S. First St.
 Rutland, Vt. 38 1/2 Center St.
 Sacramento 14, Calif. 626 Forum Bldg.
 Saginaw, Mich. Second National Bank Bldg.
 St. Louis 1, Mo. 818 Olive St.
 Salt Lake City 9, Utah 200 S. Main St.
 San Antonio 5, Texas 434 So. Main Ave.
 San Diego 1, Calif. 1240 Seventh Ave.
 San Francisco 6, Calif. 235 Montgomery St.
 San Jose 10, Calif. 460 Park Ave.
 Savannah, Ga. 4 E. Bryan St.
 Seattle 4, Wash. 710 Second Ave.
 Seattle 8, Wash. Avia. & Def., 220 Dawson St.
 Shreveport, La. 206 Beck Bldg.
 Sioux City 13, Iowa. 572 Orpheum Electric Bldg.
 South Bend 1, Ind. 112 W. Jefferson Blvd.
 Spokane 4, Wash. S. 162 Post St.
 Springfield, Ill. 607 E. Adams St.
 Springfield 3, Mass. 1387 Main St.
 Stockton, Calif. 11 So. San Joaquin St.
 Syracuse 6, N. Y. 3532 James St.
 Tacoma 1, Wash. 1202 Washington Bldg.
 Tampa 6, Fla. 1206 North A St.
 Toledo 4, Ohio 420 Madison Ave.
 Trenton 8, N. J. 214 E. Hanover St.
 Tucson, Ariz. P.O. Box 710, 650 N. Sixth Ave.
 Tulsa 3, Okla. 320 S. Boston Ave.
 Utica 2, N. Y. 258 Genesee St.
 Washington 5, D. C. 777-14th St., N.W.
 Waterloo, Iowa 206 W. 4th St.
 Wenatchee, Wash. 328 N. Wenatchee Ave.
 Wheeling, W. Va. 40 Fourteenth St.
 Wichita 2, Kan. 200 E. First St.
 Williamston, N. C. 115 E. Main St.
 Worcester 5, Mass. 288 Grove St.
 York, Pa. 56 N. Harrison St.
 Youngstown 5, Ohio 272 E. Indianola Ave.

Hawaii: American Factors, Ltd., P. O. Box 3230, Honolulu 1 Canada: Canadian General Electric Company, Ltd., Toronto

LOCOMOTIVE AND CAR EQUIPMENT DEPARTMENT, GENERAL ELECTRIC COMPANY, ERIE, PA.



RENEWAL PARTS

GEF-3281B
Supersedes GEF-3281A,
GEG-6258 and GEG-7638

TYPE 17LV30 RELAY

Forms F, H, L, M, and N

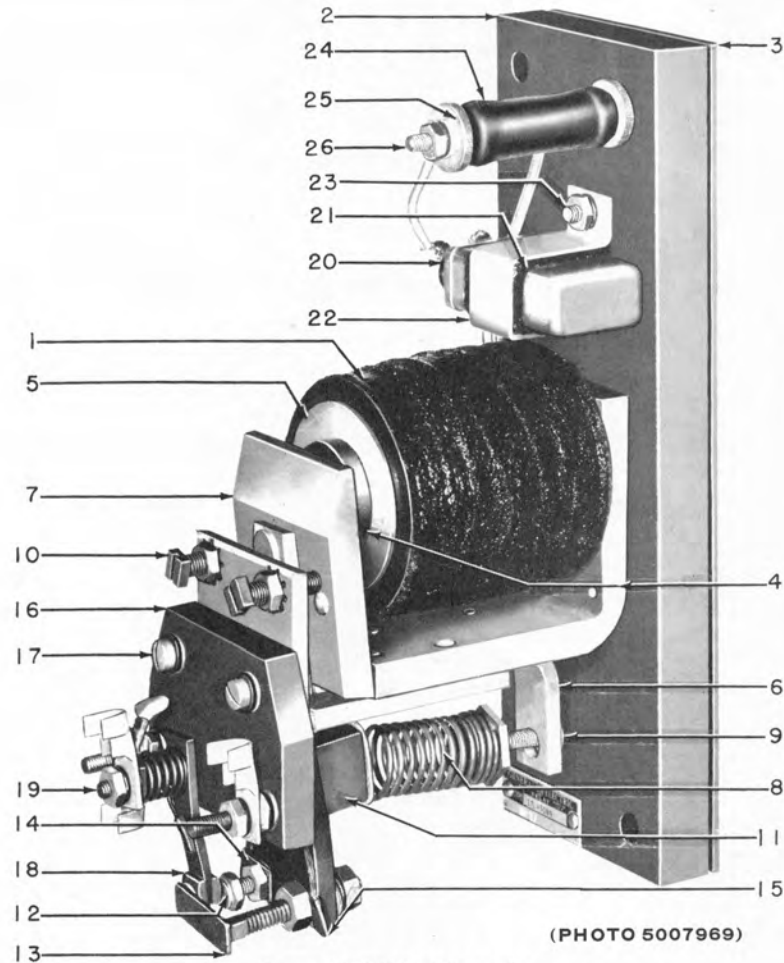

Type 17LV30N6 relay

Note: The last number in the nameplate rating is the coil number.

Example: Type 17LV30H2 requires operating coil Cat. 4739136.

Operating Coil - Ref. 1 - 1 Required

Coil No.	Coil Cat. No.
2	4739136
6	4739240
9	4739172
10	4739401

When ordering renewal parts, give quantity, catalog number, description of each item required, and complete nameplate reading.

GENERAL ELECTRIC

TYPE 17LV30 RELAY

Ref. No.	No. Req. for Type 17LV40-					Cat. No.	Description
	F	H	L	M	N		
	1	1	1	-	1	4715578	Rubber washer for operating coil
	-	-	-	2	-	N44P12006B	Screw fastening coil in position, 6-40, 3/8 in. fil. h
	3	3	2	2	2	8823750P234	Terminal screw with lock washer, for operating coil
2	1	1	-	-	-	8800013	Base
2	-	-	-	1	1	6725957	Base
2	-	-	-	-	1	8862384	Base
3	1	1	-	-	-	8800014	Insulation shield for base
3	-	-	1	1	-	6715637	Insulation shield for base
3	-	-	-	-	1	8810411	Insulation shield for base
4	1	1	1	1	1	4731776G8	Magnet frame with core
	1	1	1	1	1	N26P23016B	Bolt fastening core to magnet frame, 5/16 in. -18, 1 in. hex. h sl
	2	2	2	2	2	N26P21012B	Bolt fastening magnet frame to base, 1/4 in. -20, 3/4 in. hex. h sl
	1	1	1	-	1	4715554	Sleeve for core
5	1	1	1	-	1	4715583	Washer under core head
	1	1	1	1	1	6711820	Adjustable plug for core
	1	1	1	1	1	N74P1205	Set screw for adjustable plug, 6-40, 5/16 in. fluted soc. h, cone pnt.
6	1	1	-	-	-	4737858BB	Armature stop
6	-	-	1	1	1	4737858BG	Armature stop
	2	2	2	2	2	N26P21010B	Bolt fastening armature stop to magnet frame, 1/4 in. -20, 5/8 in. hex. h sl
7	1	1	1	1	1	6742072G14	Armature with spring bracket
8	1	1	1	1	1	4731974	Tension spring with plug, for armature
9	1	1	1	1	1	4731833P12	Adjusting screw for tension spring
10	2	2	2	2	2	6715638	Stop screw for armature
11	1	1	-	-	-	6715636	Supporting block for movable contact
11	-	-	1	1	1	6716266	Supporting block for movable contact
	1	1	1	1	1	N44P16010B	Screw fastening block to armature, 10-32, 5/8 in. fil. h
12	1	2	1	-	1	9963477G5	Contact screw with tip, straight
13	-	-	1	1	1	6715925	Contact screw with tip, offset
14	1	2	1	-	1	6711896	Shunt with terminal and binding post, No. 10 hole in terminal
15	-	-	1	1	1	6716269	Shunt with terminal and binding post, 1/4 in. hole in terminal
16	1	1	1	1	1	6725956	Supporting block for contact fingers
17	2	2	2	2	2	N44P16010B	Screw fastening finger block to armature stop, 10-32, 5/8 in. fil h
18	1	2	-	-	-	6700314	Contact finger with tip and compression spring
18	-	-	1	-	1	6700316	Contact finger with tip and compression spring
18	-	-	-	1	-	6700284	Contact finger with tip and compression spring
19	1	2	1	1	1	6706811	Guide post for contact finger
	1	2	1	1	1	6700285	Nut for guide
20	1	1	-	-	1	23F870	Capacitor 0.5 mfd
21	1	1	-	-	1	6716483	Felt pad for capacitor
22	1	1	-	-	1	6716482	Clamp for capacitor
23	1	1	-	-	1	4731833P7	Screw fastening capacitor clamp to base
24	-	-	-	-	1	482A444ASP34	Resistor unit, 1500 ohms
25	-	-	-	-	2	6712179	Insulation spacer for end of resistor unit
26	-	-	-	-	1	4731833P19	Mounting screw for resistor unit

TERMINALS

Cat. No.	Description
410567	Tinned copper
353X95	Solderless, ring tongue (Aircraft-Marine Products, Inc. Cat. 31891)
592X82	Solderless, flag type (Aircraft-Marine Products, Inc. Cat. 32067)

Note: The following items are steel unless otherwise specified.

PLAIN WASHERS

Cat. No.	Description
N402P7B	For No. 6 screw
N402P9B	For No. 10 screw
N402P11B	For 1/4 in. screw

LOCK WASHERS

Cat. No.	Description
N405P37P	For No. 6 screw
N405P39P	For No. 10 screw
N405P41P	For 1/4 in. screw, reg.
N404P25P	For 1/4 in. screw, internal teeth

NUTS

Cat. No.	Description
N210P16B	10-32 hex.
N203P21B	1/4 in. -20 hex.
4714939	1/4 in. -28 hex.

RENEWAL PARTS

TYPES 17KC63A1 AND 17KC63B1 CONTROLLERS

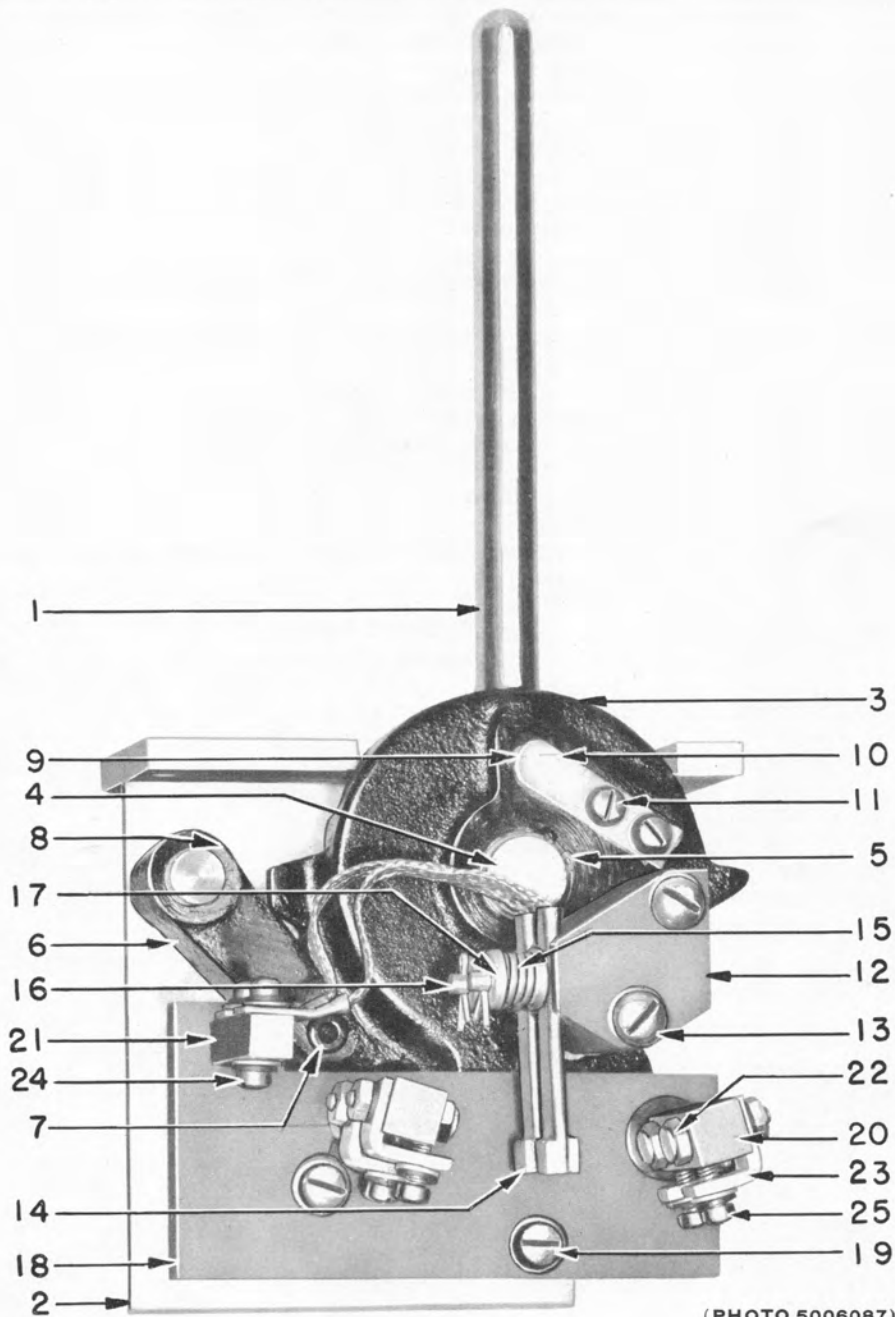

Type 17KC63B1 controller

When ordering renewal parts, give quantity, catalog number, description of each item required, and complete nameplate reading.

GENERAL  ELECTRIC

TYPES 17KC63A1 AND 17KC63B1 CONTROLLERS

Ref. No.	No. Req. for Type 17KC63-		Catalog Number	Description
	A1	B1		
1	1	1	8800465	Operating handle with guide pin
2	1	1	6735763G1	Frame with posts
3	1	1	6742798G1	Operating lever with bushing
	1	1	4756079	Bushing for operating lever (Chrysler Corp. Cat. A-838-1)
4	1	1	8800350	Hinge pin for operating lever
	1	1	N22P28016B	Bolt fastening hinge pin to frame, 1/2 in. - 20, 1 in., hex. hd.
5	1	1	N900P75	Retaining ring for operating lever
6	1	1	1979961G7	Check pawl with roller, for operating lever
7	1	1	20X696	Roller with pin for check pawl
8	1	1	N900P50	Retaining ring for check pawl
	1	1	764834	Tension spring for check pawl
9	1	1	8800466	Retaining pin for operating handle
10	1	1	8800463	Spring for retaining pin
11	2	2	N44P16008B	Screw fastening spring to operating lever, 10-32, 1/2 in., fill. hd.
12	1	-	8800354	Finger block
12	-	1	8860604	Finger block
	-	2	8807506	Spacer for finger block
13	2	-	N44P21028B	Screw fastening finger block to operating lever, 1/4 in. - 20, 1 3/4 in., fill. hd.
13	-	2	N44P21046B	Screw fastening finger block to operating lever, 1/4 in. - 20, 2 7/8 in., fill. hd.
14	1	2	9964849G2	Contact finger with shunt
15	1	2	6724961	Compression spring for contact finger
16	1	2	4702567	Spring post for compression spring
17	2	4	1450952	Retaining washer for compression spring
18	1	-	8800353	Contact block
18	-	1	8860603	Contact block
19	2	2	N44P21016B	Screw fastening contact block to frame, 1/4 in. - 20, 1 in., fill. hd.
20	2	-	6728709G2	Contact post with tip
20	-	2	8807505	Contact post
	2	-	N44P16008B	Screw fastening contact post to block, 10-32, 1/2 in., fill. hd.
	-	2	N44P21010B	Screw fastening contact post to block, 1/4 in. - 20, 5/8 in., fill. hd.
21	1	-	6728709P7	Terminal post
21	-	1	8807504	Terminal post
	1	-	N44P16008B	Screw fastening terminal post to block, 10-32, 1/2 in., fill. hd.
	-	1	N44P16010B	Screw fastening terminal post to block, 10-32, 5/8 in., fill. hd.
22	-	4	9963477G4	Stationary contact screw with tip
23	-	4	8807501	Terminal bracket
24	4	3	N44P16008B	Screw fastening terminal to post, 10-32, 1/2 in., fill. hd.
25	-	4	N44P16006B	Screw fastening terminal to bracket, 10-32, 3/8 in., fill. hd.
	A1	B1		

PLAIN WASHERS

Catalog Number	Description
N402P9B	For No. 10 screw
N402P11B	For 1/4 in. screw
N402P45B	For 1/2 in. screw

LOCK WASHERS

Catalog Number	Description
N405P39P	For No. 10 screw
N405P41P	For 1/4 in. screw
N405P45P	For 1/2 in. screw

COTTER PINS

Catalog Number	Description
N503P608B	1/16 in. by 1/2 in.
N503P1208B	1/8 in. by 1/2 in.

NUT

Catalog Number	Description
N210P16B	10-32 hex. std.

LOCOMOTIVE AND CAR EQUIPMENT DEPARTMENT



ERIE, PA.

RENEWAL PARTS



TYPE 17LC19 RELAY

Forms C, D, E, F, H, L, and M

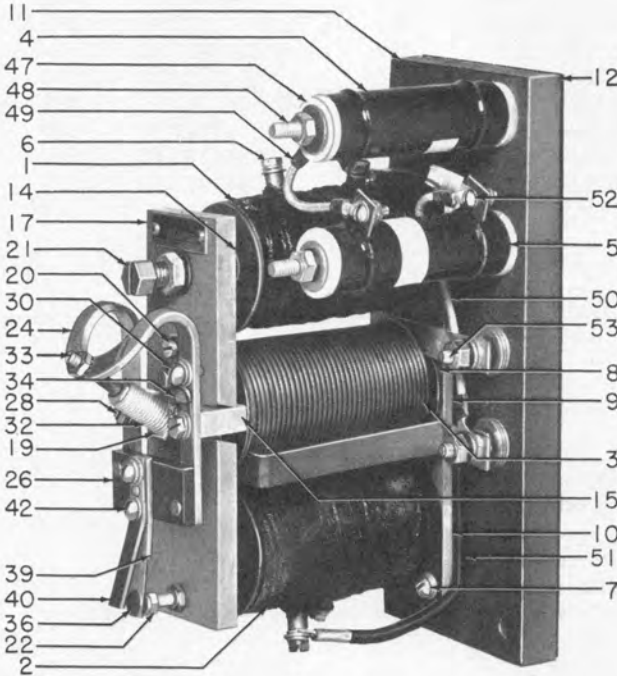

Type 17LC19D5 relay

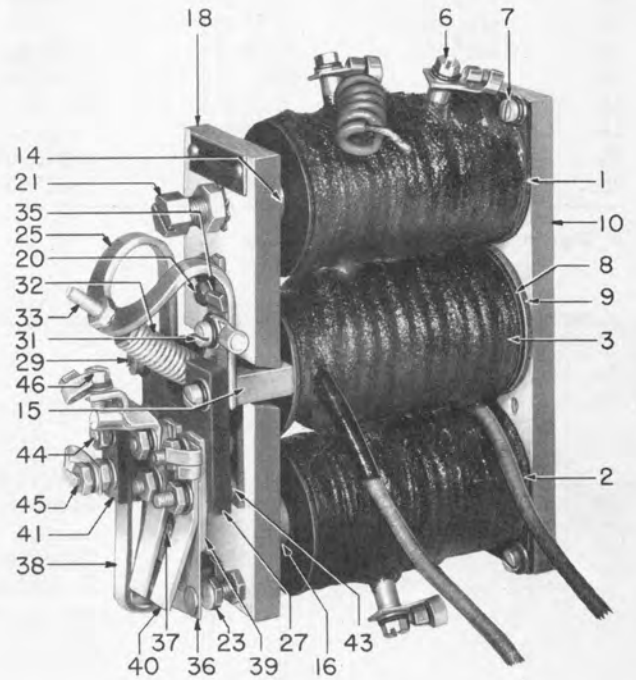

Type 17LC19E relay

NOTE: The last number in the nameplate rating is the coil and resistor unit number.
Example: Type 17LC19C3 Relay requires Operating Coil Cat. 4739205, Differential Coil Cat. 4739249, Series Coil Cat. 4739242 and Resistor Units Cat. 5758472D75L, and 5758472E39L.

COILS AND RESISTOR UNITS - 1 of each required

Coil and Res. Unit No.	Operating Coil Ref. No. 1 Cat. No.	Differential or Stabilizing Coil Ref. No. 2 Cat. No.	Series Coil Ref. No. 3 Cat. No.	Resistor Unit		Resistor Unit	
				Ref. No. 4 Cat. No.	Rating in Ohms	Ref. No. 5 Cat. No.	Rating in Ohms
3	4739205	4739249	4739242	5758472D75L	75	5758472E39L	390
4	4739205	4739026	6724049	5758472E10L	100	5758472E39L	390
5	4739205	4739206	6724050	5758472E10L	100	5758472E39L	390

When ordering renewal parts, give quantity, catalog number, description of each item required, and complete nameplate reading.



TYPE 17LC19 RELAY

Coil and Res. Unit No.	Operating Coil Ref. No. 1 Cat. No.	Differential or Stabilizing Coil Ref. No. 2 Cat. No.	Series Coil Ref. No. 3 Cat. No.	Resistor Unit		Resistor Unit	
				Ref. No. 4 Cat. No.	Rating in Ohms	Ref. No. 5 Cat. No.	Rating in Ohms
6	4739269	4739128	4739242	-----	----	-----	----
8	4739205	4739206	4739263	5758472E10L	100	5758472E39L	390
10	4739205	4739206	6725540	5758472E10L	100	5758472E39L	390
11	4739378	4739206	4739377	-----	----	-----	----
12	4739127	4739128	6728587	5758472D16L	16	5758472E10L	100
14	4739205	4739206	8823217	5758472E10L	100	5758472E39L	390
24	4739205	4739206	6728587	5758472D51L	51	5758472E30L	300
26	4739205	4739206	8862464	5758472E10L	100	5758472E39L	390
27	4739483	8860426	8865089	5758472E91L	910	5758472F62L	6200
28	4739205	4739206	4739242	5758472E10L	100	5758472E39L	390
29	4739483	8860426	4739242	5758472E39L	390	+5758472F30L	3000
30	4739127	4739128	6724049	5758472D16L	16	5758472E10L	100
33	4739205	4739206	6728587	5758472E10L	100	5758472E39L	390
34	4739205	4739206	8835011G2	5758472E10L	100	5758472E39L	390
35	4739483	8860426	9964399P1	5758472F62L	6200	5758472E91L	910
36	4739483	8860426	9964399P1	5758472F39L	3900	5758472E20L	200

+ Two required

Ref. No.	No. Req. for Type 17LC19-							Cat. No.	Description
	C	D	E	F	H	L	M		
6	4	4	4	4	4	4	4	4731833P4	Terminal screw for coil
7	4	4	4	4	4	4	4	105113	Screw fastening coil to base, 10-32, 3/8 in. r h
								6703780	Insulation tube for series coil
								6728754	Spool for series coil
8		2			2	2		6703789	Flange for series coil
9		1			1	1		4710186	Rubber washer between flange and base
10	1	1	1	1	1	1		6703761	Base
10							1	8800368	Base
11	1	1			1			6711603P1	Supporting block for base
11						1		8835012P1	Supporting block for base
11							1	8813032	Supporting block for base, for Type 17LC19M27 Relay only
							1	8813897	Supporting block for base, except Type 17LC19M27 Relay
12	1	1			1			6711602P1	Insulation shield for supporting block
12							1	8810105	Insulation shield for supporting block
	2	2			2	2	2	71X592	Screw fastening insulation shield to supporting block
	2	2			2	2	2	46X847	Screw fastening base to supporting block, 1/4 in. -20, 7/8 in. hex.h
14	1	1	1	1	1	1	1	6703772	Core for operating coil
15	1	1	1	1	1	1	1	143X28	Core with armature support and dowel pin, for series coil
16	1	1	1	1	1	1	1	6710136	Core for differential or stabilizing coil
	3	3	3	3	3	3	3	69X603	Screw fastening core to base, 1/4 in. -20, 7/8 in. hex. h brass
17	1	1					1	6703768	Armature
18			1	1	1			6703768AA	Armature
19	1	1	1	1	1	1	1	6703769	Spring seat for armature
20	2	2	2	2	2	2	2	271583	Screw fastening spring seat to armature, 8-36, 3/8 in. fil. h
21	1	1	1	1	1	1	1	6711530P1	Stop screw for armature
22,									
23	1	1	2	3	1	1	1	9963477G3	Contact screw for armature
			1	1				6712132	Finger stop for armature
			1	1				153923	Screw fastening finger stop to armature, 10-32, 5/8 in. f h
24	1	1				1	1	6703766	Spring seat bracket with finger support
25			1	1	1			6703773AA	Spring seat bracket
26	1	1				1	1	6703776	Finger support
	2	2				2	2	103951	Rivet fastening finger support to bracket, 1/8 in. br 1/2 in. f h copper
27			1	1	1			6712133	Finger block
28	2	2				2	2	4731833P6	Screw fastening basket to support
	C	D	E	F	H	L	M		

TYPE 17LC19 RELAY

GEF-3425C

Ref. No.	No. Req. for Type 17LC19-							Cat. No.	Description	
	C	D	E	F	H	L	M			
29			2	2	2			61X597	Screw fastening bracket and finger block to support, 10-32, 3/4 in. fil. h	
30	1	1					1	13034	Screw fastening terminal to bracket, 10-32, 3/8 in. r h brass	
31			1	1	1	1		243044	Screw fastening terminal to bracket, 10-32, 3/8 in. fil. h	
32	1							6721279	Compression spring for armature	
32		1	1	1	1	1	1	4735991	Compression spring for armature	
33	1	1	1	1	1	1	1	6703038	Adjustable spring seat for compression spring	
34	1	1					1	4703786	Shunt with terminals, for armature and bracket	
35			1	1	1			6712140	Shunt with terminals, for armature and bracket	
36	1	1	2	2	2	1	1	6703774	Contact finger, without shunt	
37			1	1				6712150	Contact finger with shunt	
38			1		1			6712131	Contact bracket	
39	1	1	2	3	1	1	1	6703777	Finger base (1 15/32 in. long)	
39			1		1			6712134	Finger base (1 in. long)	
40	1	1	2	3	1	1	1	6703778	Finger guard	
			1		1			6712135	Clamp for contact finger	
41			2		2			6712136	Clamping block for contact bracket	
							2	8813024	Insulation shield for contact finger	
	1	1				1	1	4731833P6	Screw fastening finger base to block	
42	2	2					2	2	105113	Screw fastening finger to base, 10-32, 3/8 in. r h
43			4	6	2				150751	Screw fastening contact finger in position, 10-32, 1 in. r h
44			1		1				145779	Screw fastening contact finger and bracket in position, 10-32, 1 1/4 in. r h
45			1						150261	Screw fastening contact finger and bracket in position, 10-32, 1 1/2 in. r h brass
45					1				160911	Screw fastening contact finger and bracket in position, 10-32, 1 1/2 in. r h
			2		2				6712137	Insulation sleeve for Cat. 145779, 150261 or 160911
46			1		1				4731833P2	Screw fastening terminal to contact bracket
47	4	4			4	4	¢		6706906	Insulation spacer for end of resistor unit
48	2	2			2	2	¢		227X75	Mounting screw for resistor unit, 1/4 in.-20, 4 1/2 in. hex. h
49	1	1			1	1			9963963G1	Shunt with terminals, between resistor units
49							1		9963963G2	Shunt with terminals, between resistor unit and terminal screw, or resistor units, 2 in.
49							1		9963963G3	Shunt with terminals, between resistor unit and terminal screw, 2 1/2 in., for Type 17LC19M27 only
50	2	2							9963963G5	Shunt with terminals, between resistor unit and operating coil or series coil, except Type 17LC19D30
50		1							8865371G2	Shunt with terminals, between resistor unit and operating coil, for Type 17LC19D30
50		1							8839356G1	Shunt with terminals, between resistor unit and series coil for Type 17LC19D30
50						1			8865371G2	Shunt with terminals, between resistor unit and operating coil
51		1							8865371G5	Shunt with terminals, between resistor unit and differential coil, except Type 17LC19D28 and -D30
51		1							8865371G6	Shunt with terminals, between resistor unit and differential coil, for Type 17LC19D28
51		1							8839356G2	Shunt with terminals, between resistor unit and differential coil, for Type 17LC19D30
52	4	4			4	4	6		207248	Terminal screw for resistor unit, 8-36, 1/2 in. r h
53	2								50X499	Terminal screw for block, 1/4 in.-20, 1 1/8 in. hex. h
53		2			2				353X83	Terminal screw for block, 1/4 in.-20, 1 1/2 in. hex. h
53							¢		4731833P12	Terminal screw for block, 10-32
53							¢		48X45	Screw fastening series coil lead to block, 1/4 in.-20, 1 3/4 in. hex. h
53							¢		65X433	Screw fastening series coil lead to block, 1/4 in.-20, 3 3/4 in. hex. h
53						2			8862120G1	Connection stud with block, for series coil
							¢		8865095P1	Spacing sleeve for Cat. 48X45
							¢		8865095P2	Spacing sleeve for Cat. 65X433
						2			8810107	Spacing block for stud

¢ Quantity variable

TYPE 17LC19 RELAY

TERMINALS

Cat. No.	Description
353X95	Solderless, No. 16 wire, No. 10 screw (†31891)
355X4	Solderless, No. 16 wire, 1/4 in. screw (†31894)
365X86	Solderless, No. 14 wire, No. 10 screw, 27/32 in. long (†31903)
352X30	Solderless, No. 14 wire, No. 10 screw, 1 1/64 in. long (†33726)
370X7	Solderless, No. 14 wire, 1/4 in. screw (†31906)
367X79	Solderless, slotted (†34080)
410567	Tinned copper, flag type, 3/8 in. wide
4709669	Tinned copper, flag type, 1/2 in. wide
411217	Flag type, 5/8 in. wide
6712101	Punched copper tube, 1/4 in. cable
1444457	Punched copper tube, 5/16 in. cable

NOTE: The following items are steel unless otherwise specified.

PLAIN WASHERS

Cat. No.	Description
155830	For No. 8 screw
150279	For No. 10 screw
143974	For 1/4 in. screw
141259	For 3/8 in. screw

LOCK WASHERS

Cat. No.	Description
54X473	For No. 8 screw
54X441	For No. 10 screw
71X749	For No. 10 screw, external teeth (\$1110)
66X190	For No. 10 screw, CSK (\$1510)
30X562	For 1/4 in. screw
6X815	For 3/8 in. screw
84X263	For 3/8 in. screw, internal teeth (\$1220)

NUTS

Cat. No.	Description
145996	10-32, hex. std
151175	10-32, hex. std, brass
1X452	1/4 in.-20, hex. std
141255	3/8 in.-16, hex. std
289784	3/8 in.-24, hex. std, jam

† Aircraft-Marine Products Co.

§ Shakeproof Lock Washer Co.

LOCOMOTIVE AND CAR EQUIPMENT DEPARTMENT

GENERAL  ELECTRIC

ERIE, PA.



RENEWAL PARTS

GEG-3795B
Supersedes GEG-3795A

MECHANICAL PARTS OF DIESEL-ELECTRIC LOCOMOTIVE CLASS B-B-88/88-4GE733

PARTS	FIG. NO.	PAGE NO.
CAB AND PLATFORM	1	3
COUPLER POCKET	2	4
COUPLER PARTS	3	4
CAB WINDOWS	4	5
THROTTLE CONTROL	5	8
TRUCK	6	9
BRAKE HANGER AND LEVER	7	10
WHEELS AND AXLE	8	11
MOTOR SUSPENSION	9	12
JOURNAL BOX PARTS	10	13
HAND BRAKE	11	14

When ordering renewal parts, give quantity, catalog number, description of each item required, and complete nameplate reading.

GENERAL  ELECTRIC

PLATFORM

Fig. No.	Ref. No.	Cat. No.	No. Required	Description
1	1	137X94	1	Platform with center plates, push pole pockets and grab handles
		6731564G1	2	#Center plate with wearing ring
		6731564P2	2	#Wearing ring
1	2	4714656	4	#Push pole pocket
1	3	6730541P3	4	Grab handle
		6731565G2	4	#Lifting hook with wearing plate, side bearing
		6731565P8	4	#Wearing plate
		*497A746P1	2	Cap with wrench, fuel oil filler pipe
		4747874G1	2	Adapter with cover, fuel pipe
1	4	6754703G1	1	Skirt, A side
1	4	6754702G1	1	Skirt with doors, B side
1	5	6754702G2	2	Door with hinges and latch
1	6	6754599P14	4	Hinge
1	7	4741724G2	2	Latch with handle
		4741724P3	2	Bushing, handle
		4741724P5	2	Latch, handle
		4764954G1	2	Spring, latch
1	7	4741724P2	2	Handle, latch
		6754611G1	1	Battery box
		4726752P21	2	Gage, fuel oil
1	8	133X31	2	Side step, right hand facing either side of locomotive
1	9	133X32	2	Side step, left hand facing either side of locomotive
1	10, 11	*499A908AAP1	18	Flange with post, hand rail
1	12	4749800P3	2	Hand rail, right hand, No. 2 end, B side or No. 1 end, A side
1	13	4749800P2	2	Hand rail, left hand, No. 2 end, B side or No. 1 end, A side
1	14	4749800P1	2	Hand rail, right hand, No. 1 end, B side or No. 2 end, A side
1	15	4749800P4	2	Hand rail, left hand, No. 1 end, B side or No. 2 end, A side
1	16	140X88	2	End step with supports, right hand facing either end of locomotive
1	17	140X89	2	End step with supports, left hand facing either end of locomotive
		*4726934G6	1	Bell and bell ringer (see GEG-5873)

COUPLER PARTS

Fig. No.	Ref. No.	Cat. No.	No. Required	Description
2	27	9962572P2	2	Pocket with pin, coupler
2	28	*41A200570P1	2	Coupling pin (National Castings Co., No. 1370)
		*N22P51088	8	Bolt, pocket, 1 1/2 in.-6, 5 1/2 in. hex. hd.
		*N203P51	16	Nut, 1 1/2 in.-6, hex.
3	30	*8825114	2	Coupler (National Castings Co., Dwg. 02E64)
3	31	145X47	2	Bushing (Association of American Railways, No. B-40)
3	32	145X48	2	Knuckle (Association of American Railways, No. E-50 HT)
3	33	145X49	2	Knuckle pin (Association of American Railways, No. C-10)
3	34	145X50	2	Knuckle thrower (Association of American Railways, No. E-30)
3	35	145X51	2	Lock (Association of American Railways, No. E-40 HT)
3	36	145X52	2	Lock lifter (Association of American Railways, No. E6-A)
1	37	*6741477P1	2	Uncoupling lever, right hand
1	38	*6741477P2	2	Uncoupling lever, left hand
1	39	6731557P2	2	Uncoupling lever, middle
		*6707533	12	#Stop
1	40	6729249P1	2	Link, uncoupling lever
		2700327	2	Head pin, link
		*N503P2220B	2	Cotter pin, 1/4 in. by 1 1/4 in.

#Must be welded in position when furnished separately.

*Added or changed since last issue.

MECHANICAL PARTS OF DIESEL-ELECTRIC LOCOMOTIVE

GEG-3795B

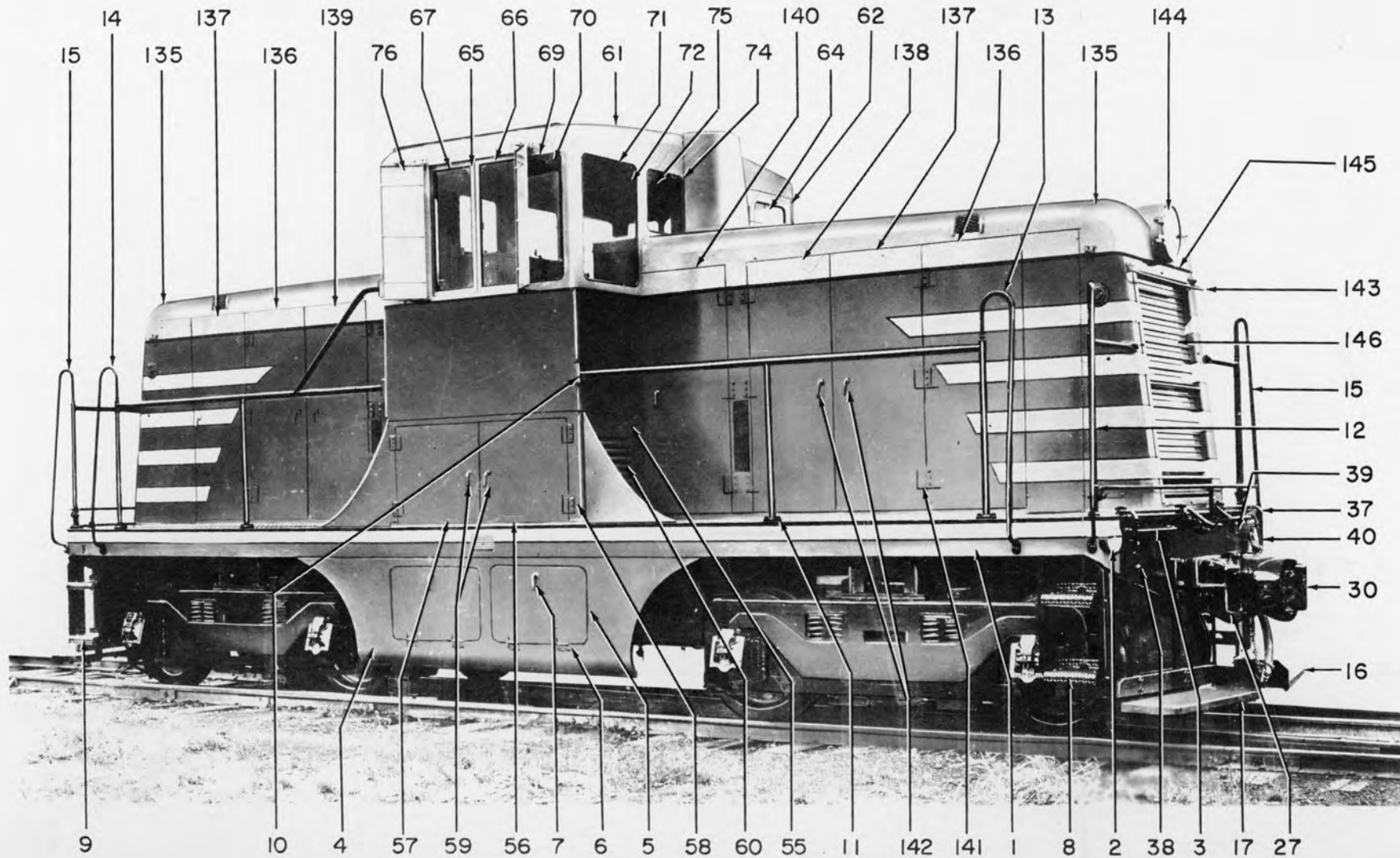

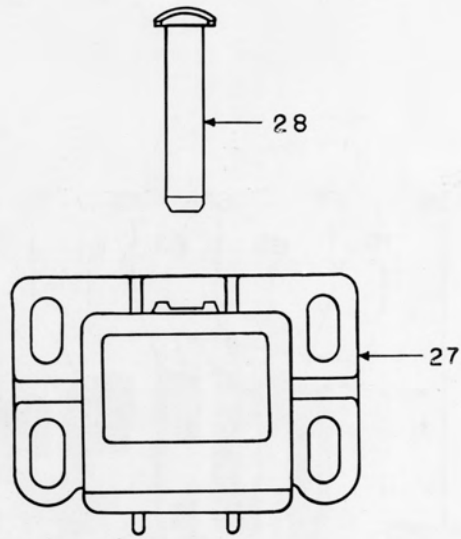

FIG. 2

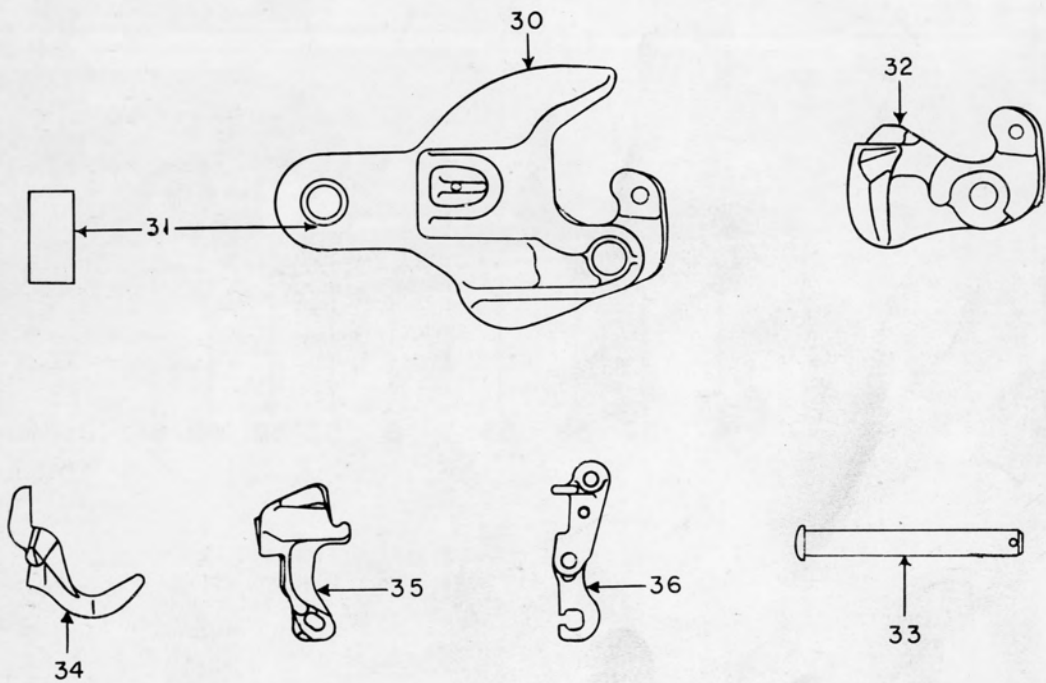

FIG. 3



RENEWAL PARTS

GEG-4720C
Supersedes GEG-4720B

MECHANICAL PARTS OF DIESEL-ELECTRIC LOCOMOTIVE CLASS B-B-88/88-4GE733

NOTE: The parts of the above locomotive are identical with those listed in bulletin GEG-3795 attached, with the following exceptions: Cat. No's. 6754712G6, 6708662, 6719326, 6731642P1, 6719059, 6707568, 6707569, and 6720039 appearing in GEG-3795 should not be used when ordering parts for the above locomotive.

Cat.No.	No. Re- quired	Description
6754712G7	1	Control compartment, No. 1 end
*8821297G1	1	Controller locking device with wearing plate

*Added or changed since last issue.

When ordering renewal parts, give quantity, catalog number, description of each item required, and complete nameplate reading.

GENERAL  ELECTRIC

5-63(50)

Data subject to change without notice.

PRINTED
IN
U. S. A.
E

OPERATOR'S CAB

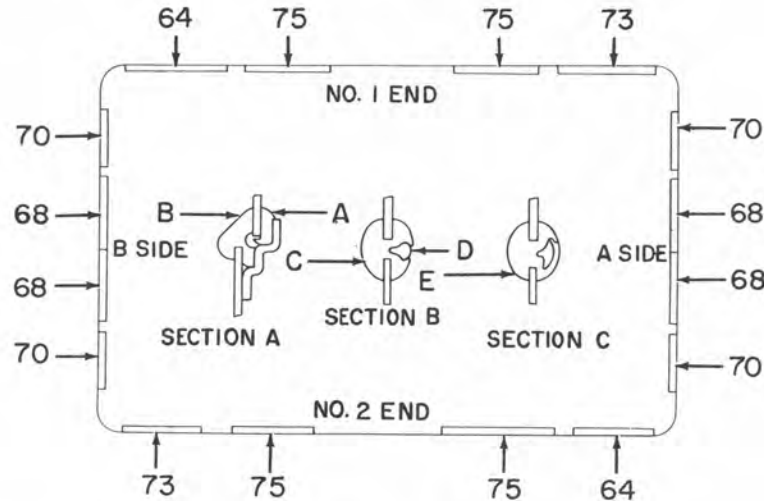

FIG. 4

Fig. No.	Ref. No.	Cat. No.	No. Required	Description
1	55	6799106G1	1	Base with doors, operator's cab
1	56	6731605G2	2	Door with hinges and latch, right hand
1	57	6731605G1	2	Door with hinges and latch, left hand
1	58	*499A903AAP4	8	Hinge (Griffin Mfg. Co., Cat. No. 255, 3 1/2 in. by 3 1/2 in. loose pin, flat back, butt. blank)
		4741724P13	4	Latch
		4764954G1	4	Spring
1	59	4741724P2	4	Handle
		4741724P3	4	Bushing, handle
1	60	8830260G1	4	Louver
		6732573P4	40	Blade
1	61	-----	-	Operator's cab
1	62	139X42	2	‡Door with hinges, lock and window, operator's cab
1		8821080P1	6	Hinge
		915X19	§	Weatherstrip, approximately 27 feet required per cab
		6741285G1	2	Lock, (see GEG-5874)
		*342B794P1	2	Door holder
1	64	4749837G17	2	‡Window
		4749837P34	2	Frame with rubber seal
4	64	6723279P11	2	‡Safety glass, 17 5/8 in. by 30 1/16 in. by 3/16 in. thick, round corners, 1 29/32 in. radius
1	62	945X69	2	‡Door with hinges, lock and window, operator's cab
4	64	*499A909AAP31	2	‡Safety glass, 17 1/4 in. by 29 11/16 in. by 15/64 in. thick, round corners, 1 11/16 in. radius
		4747815P30	4	@Weatherstrip, sliding window
4	68	6720516P1	4	@Safety glass, 13 5/8 in. by 32 1/8 in. by 3/16 in. thick, square corners
1	65	*8834422G4	2	@Sliding window, operator's cab
1	66	8834420G3	2	@Frame with strike
1	67	8834420G2	2	@Frame with catch
		930X98	§	@Weatherstrip, approximately 12 feet required per cab
4	68	*499A909AAP15	4	@Safety glass, 12 1/4 in. by 31 3/4 in. by 15/64 in. thick, round corners, 1 11/16 in. radius
1	69	4747815G3	4	¢Fixed window, operator's cab, side
1	69	4747815P10	4	¢Frame with rubber seal

*Added or changed since last issue.

‡Two designs of doors have been furnished. Therefore extreme caution should be used when ordering parts.

§Specify length required. Material will be furnished to nearest stock length.

@Two designs of windows have been furnished. The first design used a seal, Ref. A, B. The first design of window is obsolete and will not be furnished. Glass and seal will however be furnished. Extreme caution should be used when ordering renewal parts.

¢Two designs of windows have been furnished on these locomotives. Therefore, extreme care should be taken when ordering renewal parts.

MECHANICAL PARTS OF DIESEL-ELECTRIC LOCOMOTIVE

Fig. No.	Ref. No.	Cat. No.	No. Required	Description
4	70	6720419P2	4	☿Safety glass, 12 5/8 in. by 32 1/8 in. by 3/16 in. thick, round corners, 1 29/32 in. radius
4	70	*499A909AAP15	4	☿Safety glass, fixed window, 12 1/4 in. by 31 3/4 in. by 15/64 in. thick, round corners, 1 11/16 in. radius
1	71	4747815G4	2	☿Large window, operator's cab, either end
1	72	4747815P11	2	☿Frame with rubber seal
4	73	6720419P3	2	☿Safety glass, 24 5/8 in. by 32 1/8 in. by 3/16 in. thick, round corners, 1 29/32 in. radius
4	73	*499A909AAP41	2	☿Safety glass, large window, 24 1/4 in. by 31 3/4 in. by 15/64 in. thick, round corners, 1 11/16 in. radius
1	74	4747815G5	4	☿Small window, operator's cab, fixed
1	74	4747815P12	4	☿Frame with rubber seal
4	75	6720419P4	4	☿Safety glass, 16 5/8 in. by 17 5/8 in. by 3/16 in. thick, round corners, 1 29/32 in. radius
4	75	*499A909AAP25	4	☿Safety glass, small window, 16 1/4 in. by 17 1/4 in. by 15/64 in. thick, round corners, 1 11/16 in. radius
4	A	926X49	\$	☿Rubber seal, safety glass, inside, approximately 120 feet required per cab
4	B	926X57	\$	☿Rubber seal, safety glass, outer, approximately 120 feet required per cab
4	E	*972X62	\$	☿Rubber seal, safety glass, approximately 120 feet required per cab
1	76	*8821329P1	2	Rear view mirror
		6740077G1	1	Seat with stand, operator
		4726766G5	1	Stand
		119X23	1	Seat with back and cushions
		4764963	1	Compression spring
		6731602G1	1	Arm rest, operator
		421066	4	Insulator, shunt
		*492A463G1	4	Insulated bolt, insulator
		498219	4	Washer, insulated bolt
		6754712G6	1	Control compartment with doors, No. 1 end
		6754399G2	1	Control compartment with doors, No. 2 end
		6753468G3	2	Door with hinges and latch, left hand
		6753468G4	1	Door with hinge for Cat. 6754712G6, middle
		6753468G6	1	Door with stop for Cat. 6754399G2, middle
		6753468G5	1	Door with hinge and latch for Cat. 6754712G6
		6753468G7	1	Door with latch for Cat. 6754399G2
		8821178P1	5	Hinge for Cat. 6753468G3 and 6753468G4
		8825253P1	1	Hinge for Cat. 6753468G5
		132X36	3	Latch with spring for Cat. 6753468G3 and 6753468G7
		4741724P13	1	Latch for Cat. 6753468G5
		4764954G1	1	Spring, latch
		4741724P2	4	Handle, door

APPARATUS CAB

Fig. No.	Ref. No.	Cat. No.	No. Required	Description
1	135	6799104G1	2	Apparatus cab with doors
1	136	6754615G2	4	Door with latch, 1st, 7th B side or 2nd, 8th A side from No. 2 end
1	137	6754615G1	4	Door with latch, 2nd, 8th B side or 1st, 7th A side from No. 2 end
1	138	6754615G4	2	Door with hinges and latch, 3rd B side or 6th A side from No. 2 end
1	139	6754615G3	2	Door with hinges and latch, 6th B side or 3rd A side from No. 2 end
1	140	6754615G6	2	Door with hinges and latch, 4th B side or 5th A side from No. 2 end
1		6754615G5	2	Door with hinges and latch, 5th B side or 4th A side from No. 2 end

☿Two designs of windows have been furnished on these locomotives. Therefore, extreme care should be taken when ordering renewal parts.

*Added or changed since last issue.

§Specify length required. Material will be furnished to nearest stock length.

MECHANICAL PARTS OF DIESEL-ELECTRIC LOCOMOTIVE

GEG-3795B

Fig. No.	Ref. No.	Cat. No.	No. Re-quired	Description				
1	141	6729227P2	22	Hinge				
		176X40	14	Latch rod with spring, upper				
		945X70	2	Latch rod with spring for Cat. 6754615G5, upper				
		4764954G1	16	Spring				
		6741838P5	14	Latch rod, lower				
		6741838P20	2	Latch rod for Cat. 6754615G5, lower				
		6732274G2	8	Link with pins for Cat. 6754615G2, 6754615G4 or 6754615G5				
		6732274G1	8	Link with pins for Cat. 6754615G1, 6754615G3 or 6754615G6				
		6720048	32	Compression spring, link				
		6708692	16	Bushing, handle				
		*N216P29B	16	Slotted nut, 1/2 in.-13, hex.				
		*N503P920B	16	Cotter pin, 3/32 in. by 1 1/4 in.				
		1	142	4741724P2	16	Handle, latch		
				6729227P1	12	Hinge, door		
2705339	4			Cover, sand box clean-out hole				
2705346	4			Gasket, cover				
*N22P23014B	16			Bolt, cover, 5/16 in.-18, 7/8 in. hex. hd.				
*N405P42P	16			Lock washer, 5/16 in.				
1	143			6720625P1	2	Grab handle		
				*N22P33024	4	Bolt, grab handle, 5/8 in.-11, 1 1/2 in. hex. hd.		
				*N203P33	4	Nut, 5/8 in.-11, hex.		
				*N405P47	4	Lock washer, 5/8 in.		
				1	144	6730059G1	2	#Housing, headlight
						926X57	\$	Gasket, housing, approximately 8 feet required per locomotive
						6732307P1	4	Lamp bracket
						*N51P21020B	16	Screw, lamp bracket, 1/4 in.-20, 1 1/4 in. fl. hd.
		*N203P21B	16			Nut, 1/4 in.-20, hex.		
		*N405P41P	16			Lock washer, 1/4 in.		
		6740289P1	2			Pulley, generator		
		9949138P1	2			Pulley, exciter		
		*499A905ACP12	6			Belts, exciter and air compressor drive		
		8821382P1	8			Mounting pad, engine or generator, U shape		
*2760652P27	4	Bolt, engine						
*2760652P19	4	Bolt, generator						
N402P50	8	Washer, 1 in.						
*N216P39	8	Slotted nut, 1 in.-8, hex.						
*N503P2232B	8	Cotter pin, 1/4 in. by 2 in.						
6731592G1	2	Flexible connection, muffler						
6754617P13	2	Flange, flexible connection, engine end						
6754617P14	2	Gasket, flexible connection and engine						
6754617P7	4	Gasket between flexible connection and muffler						
1	145	6754639G1	2	Winter front				
		6731640G1	34	Blade				
1	146	6720038	34	Coil spring, operating bar				
		6740272G1	2	Reservoir, lubricating oil				
		*497A746P1	2	Cap with wrench				
		4725354G1	2	Fuel tank, hot water heater				
		945X71	2	Cap				
		4759376	4	Sand trap (Graham-White Sales Corp., No. 209)				
		144X54	4	Sand hose				
		*499A910AAP2	8	Hose clamp				
		155X92	2	Water gage, filler pipe				
		155X93	2	Glass				
		*355X31	2	Washer, 5/8 in. O.D. glass				
		6720462P1	4	Funnel, filling radiator				
		337X26	2	Hot water hose to heater, upper				
		144X56	4	Hose to oil cooler				
		144X57	6	Hose to fuel tank or filter				
		144X55	2	Hot water hose to water heater, lower				
		*499A910AAP2	20	Hose clamp				
		*499A910AAP3	24	Hose clamp				
		*499A924CDP1	1	Emergency fuel shut-off valve				

*Added or changed since last issue.

#Must be welded in position when furnished separately.

\$Specify length required. Material will be furnished to nearest stock length.

THROTTLE CONTROL

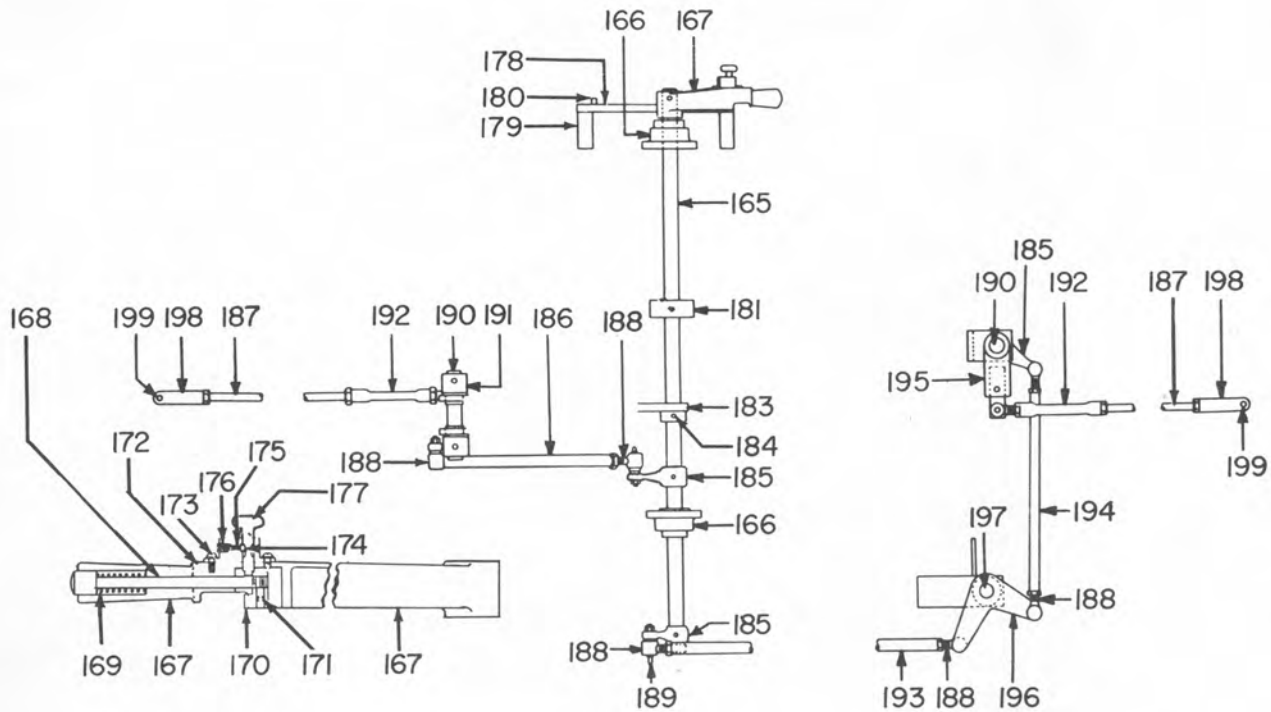

FIG. 5

Fig. No.	Ref. No.	Cat. No.	No. Required	Description
5	165	6729571P2	1	Shaft, throttle control
5	166	*497A713P1	2	Bearing, shaft
5	167	6730254G1	1	Handle with locking device
5	168	4746222P6	1	Pin
5	169	6720074	1	Compression spring
5	170	6730254P2	1	Locking pawl
5	171	*N70P2106	1	Set screw, 1/4 in.-20, 3/8 in. hex. socket, cup point
5	172	6730254P3	1	Locking device body
5	173	*N37P16006B	2	Screw, 10-32, 3/8 in. rd. hd.
		*N405P39P	2	Lock washer, No. 10
5	174	*499A917AAP2	1	Ball, stop pin, 3/16 in. dia.
5	175	92X563	1	Compression spring, ball
5	176	*N71P2106	1	Set screw, compression spring, 1/4 in.-20, 3/8 in. headless, cup point
5	177	6708648	1	Stop pin, handle
5	178	6729306P1	1	Quadrant
5	179	6719325	2	Spacer, quadrant
		*N51P25060B	2	Screw, quadrant or spacer, 3/8 in.-16, 3 3/4 in. fl. hd.
5	180	*8866636P63	2	Stop pin, handle, 5/16 in. dia., 7/8 in. long
5	181	6708662	1	Cam, controller shaft
		*N72P2516	1	Set screw, cam, 3/8 in.-16, 1 in. sq. hd., cup point
		6719326	1	Starwheel throttle shaft
		6731642P1	1	Lever between cam and starwheel
		6719059	1	Roller, lever
		6707568	1	Head pin, roller
		6707569	1	Head pin, lever
		*N503P1216B	1	Cotter pin, 1/8 in. by 1 in.
		*N503P1212B	1	Cotter pin, 1/8 in. by 3/4 in.
		6720039	1	Tension spring, lever
5	182	*N500P2548	1	Taper pin, cam, No. 4, 3 in. long
		*N500P1920	1	Taper pin, starwheel, No. 2, 1 1/4 in. long
5	183	6720875G2	1	Lever, throttle switch

*Added or changed since last issue.

Fig. No.	Ref. No.	Cat. No.	No. Required	Description
5	184	*N500P2528	5	Taper pin, No. 4, 1 3/4 in. long
		8825021P1	1	Adjusting rod, throttle switch
		4741899P14	2	Clevis, adjusting rod
		*N203P25B	2	Lock nut, clevis, 3/8 in.-16, hex.
		4714680	2	Pin, clevis
		*N503P1212B	2	Cotter pin, 1/8 in. by 3/4 in.
		*N500P2528	1	Taper pin lever, No. 4, 1 3/4 in. long
		4749400P7	2	Lever, shaft
		*N500P2528	3	Taper pin, handle or lever, No. 4, 1 3/4 in. long
		4749689P42	1	Connecting rod, 29 1/2 in. long, No. 1 end
5	186	4749689P7	2	Connecting rod, 52 in. long, either end
5	187	*497A639P2	8	Bearing socket, connecting rods
5	188	*497A706P5	8	Lubricant fitting, bearing socket (Alemite Division of Stewart-Warner Corp., No. 1636)
5	189	*N2800P2	2	Lubricant fitting, ball bearing
5	190	6754722P41	1	Shaft, adjusting lever
5	191	369X27	2	Bearing, shaft
5	192	6754722P21	2	Turnbuckle
5	193	4749689P47	1	Connecting rod, 53 1/2 in. long, No. 2 end
5	194	4749689P48	1	Connecting rod, 13 in. long, No. 2 end
5	195	6731646G1	2	Adjustable lever
5	196	137X93	1	Bell crank, shaft
5	197	6754722P10	1	Shaft, bearings, No. 2 end
5	198	8816108	2	Clevis, connecting rod
5	199	2719697	2	Pin, clevis
		*N503P608B	2	Cotter pin, 1/16 in. by 1/2 in.
		155X90	2	Engine stop control

TRUCK

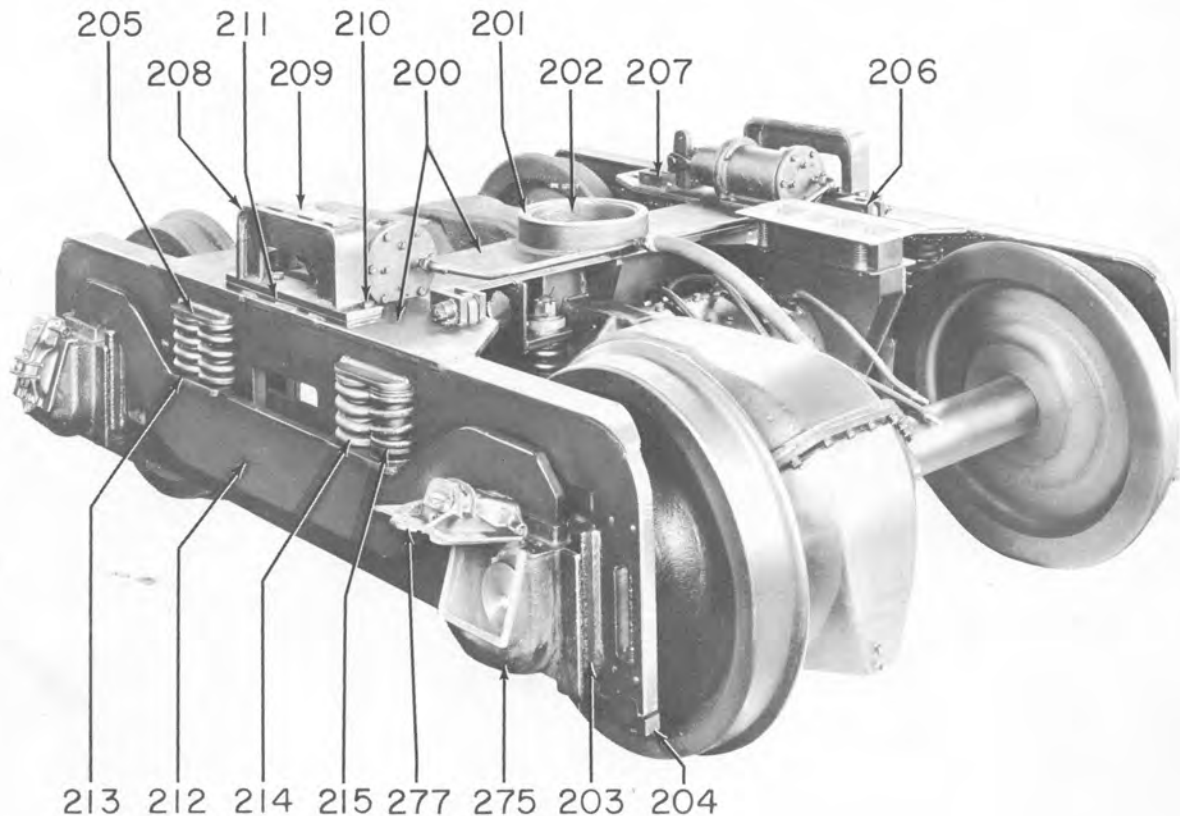

FIG. 6

*Added or changed since last issue.

Fig. No.	Ref. No.	Cat.No.	No. Re-quired	Description
6	200	6799101G1	2	Frame with center plate, journal box guides and stay plates
6	201	6731564G2	2	#Center plate with wearing ring
6	202	6731564P7	2	#Wearing ring
6	203	115X18	16	#Journal box guide with wearing plate
6	203	6720385P1	16	#Wearing plate
6	204	6720383P1	8	Stay plate
		*N22P35096	16	Bolt, stay plate, 3/4 in.-10, 6 in. hex. hd.
		*N203P35	16	Nut, 3/4 in.-10, hex.
		*N405P48	16	Lock washer, 3/4 in.
6	205	137X99	8	#Spring seat, upper
6	206	6723896P1	2	#Clevis, brake lever
6	207	6720631P2	2	#Clevis, brake hanger, right hand
6	207	6720631P1	2	#Clevis, brake hanger, left hand
		6729252P1	2	Wearing plate, center plate
6	208	6731565G1	4	Base with wearing plate, side bearing
6	209	6731565P4	4	#Wearing plate
6	210	*N22P35052	16	Bolt, base, 3/4 in.-10, 3 1/4 in. hex. hd.
		*N203P35	16	Nut, 3/4 in.-10, hex.
		*N405P48	16	Lock washer, 3/4 in.
6	211	6741079P2	4	Shim, base
6	212	6730036P1	8	Equalizer
6	213	4759294	8	Seat, coil spring, lower
6	214	*502A178	12	Coil spring, equalizer, inner (Association of American Railways, 3 1/4 in. O.D., 6 1/2 in. long, 5/8 in. dia. wire)
6	214	*497A695	12	Coil spring, equalizer, outer (Association of American Railways, 5 3/8 in. O.D., 6 5/8 in. long, 1 in. dia. wire)
6	215	*497A696P1	4	Snubber (Cardwell-Westinghouse Co., Type B)

BRAKE HANGERS AND LEVERS

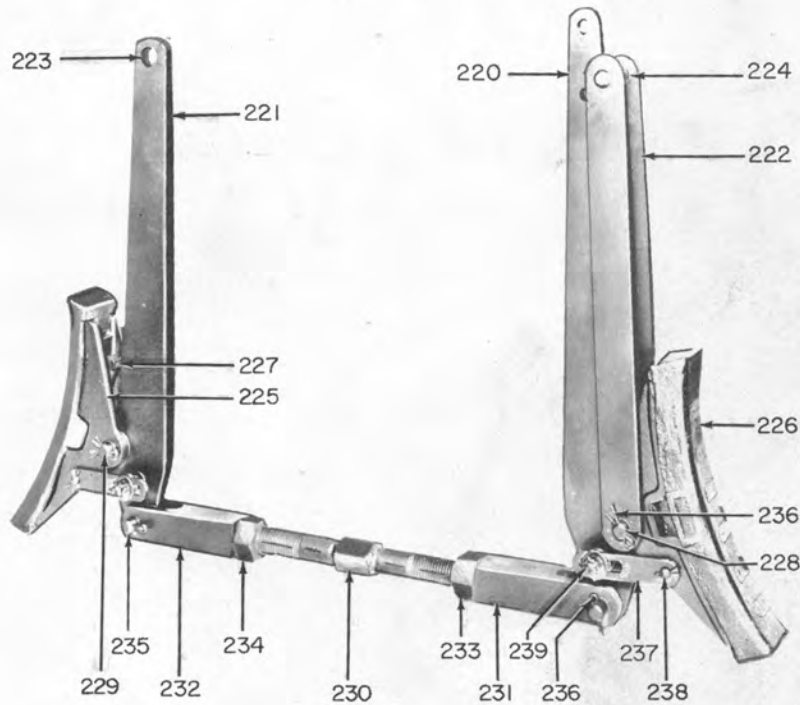

FIG. 7

#Must be welded in position when furnished separately.

*Added or changed since last issue.

Fig. No.	Ref. No.	Cat. No.	No. Re-quired	Description
7	220	6741950G2	2	Brake lever with bushings, 34 3/8 in. long
7	220	6741950G4	2	Brake lever with bushings, 31 1/2 in. long
7	221	6741950G3	2	Brake lever with bushings, 28 7/8 in. long
7	221	6741950G6	2	Brake lever with bushings, 28 7/8 in. long, other hand
7	222	6741950G5	8	Brake hanger with bushings
7	223	8825340P1	4	Bushing, 1.134 in. I.D., 1.504 in. O.D., 1 in. long
7		8825341P3	10	Bushing, 1.259 in. I.D., 1.629 in. O.D., 1 in. long
		8825341P5	8	Bushing, 1.259 in. I.D., 1.629 in. O.D., 1 1/4 in. long
7	224	8825341P1	16	Bushing, 1.259 in. I.D., 1.629 in. O.D., 5/8 in. long
7	225	8861504G1	8	Brake shoe head with bushings. Cat. stamped on head.
		8825341P4	16	Bushing
7	226	6732095P1	8	Brake shoe. Cat. stamped on shoe.
7	227	6720889P1	8	Key, brake shoe or head
7	228	*6723837P36	4	Pin, brake hanger, brake shoe head or brake lever
7	229	*6723837P26	4	Pin, brake shoe head or brake lever
7	230	6720375P1	4	Compression rod
7	231	6729017G1	4	Clevis with bushings, right hand tap
7	232	6729017G2	4	Clevis with bushings, left hand tap
		8825341P1	16	Bushing
7	233	281X85	4	Jam nut, clevis, 1 3/4 in.-5, hex. R.H.
7	234	281X86	4	Jam nut, clevis, 1 3/4 in.-5, hex. L.H.
7	235	*6723837P16	8	Pin, clevis or brake lever
7	236	*N503P3332B	32	Cotter pin, 3/8 in. by 2 in.
		6708696	4	Suspension pin, brake hanger
		6731567P2	4	Suspension bolt, brake lever
		6731346P3	4	Bushing, suspension bolt
		4764903	4	Compression spring, suspension bolt
		6707534	4	Washer
		6707436	4	Slotted nut
		*N503P2232B	4	Cotter pin, 1/4 in. by 2 in.
7	237	6707434	8	Link, friction device
7	238	6707532	8	Pin, brake shoe head or link
7	239	6729008P3	8	Bolt, brake lever or link
		4764903	8	Compression spring, link
		6707435	16	Seat, compression spring
		4768073P6	8	Slotted nut, 3/4 in.-10, hex.
		*N503P2224B	24	Cotter pin, 1/4 in. by 1 1/2 in.

WHEELS AND AXLE

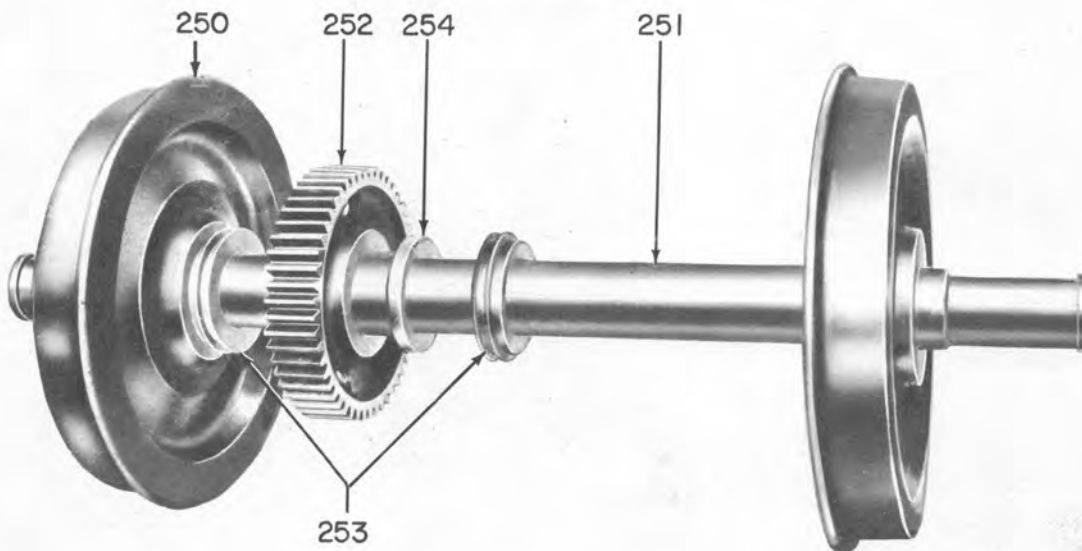

FIG. 8

*Added or changed since last issue.

Fig. No.	Ref. No.	Cat. No.	No. Required Per Loco.	Description
8	250	6732754G1	4	Wheels; axle, solid gear and lubricant flingers
8	251	*342B458P16	8	Wheel
8	252	6730040P1	4	Axle
8	253	*2792444P1	4	Solid gear
8	254	6705170	8	Lubricant flinger
8		6705173	4	Spacing ring

MOTOR SUSPENSION



FIG. 9

Fig. No.	Ref. No.	Cat. No.	No. Required	Description
9	260	2760655P71	4	Suspension bolt
9	261	6719185	8	Washer
9	262	6723060P1	16	Rubber pad
9	263	6723264P1	4	Seat, suspension spring
9	264	702873	4	Suspension spring
9	265	6719184	4	Bushing, suspension bolt
9	266	6719067	16	Screw, washer or rubber pad
9	267	*N216P51	4	Slotted nut, 1 1/2 in.-6, hex.
9	268	*N503P2848B	4	Cotter pin, 5/16 in. by 3 in.
		6723298G1	4	Safety strap, suspension bolt
		*N22P39044	8	Bolt, safety strap, 1 in.-8, 2 3/4 in. hex. hd.
		*N203P39	8	Nut, 1 in.-8, hex.
		*N405P50	8	Lock washer, 1 in.

*Added or changed since last issue.

JOURNAL BOX PARTS

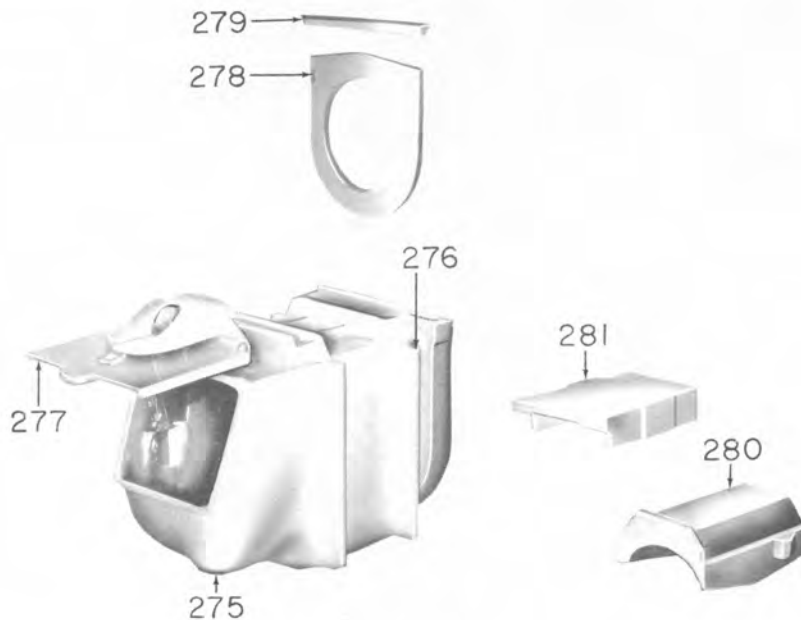

FIG. 10

Fig. No.	Ref. No.	Cat.No.	No. Required	Description
6, 10	275	4759290	8	Journal box with lid, does not include dust guard, wedge or journal bearing (National Castings Co., Dwg. L-3380, 5 in. by 9 in.)
10	276	191X8	16	#Pedestal liner (National Castings Co., No. 29978)
6, 10	277	4759291	8	Lid (National Castings Co., Flexo No. 409)
10	278	116X52	8	Dust guard, journal box (George Jenkins Co., Type 400, leather fiber steeple top, 5 in. by 9 in.)
10	279	116X53	8	Wedge, dust guard (George Jenkins Co., leather fiber, 5 in. by 9 in.)
10	280	4757211	8	Bearing, journal box (National Bearing Metals Corp., A.T.A.-13118, 5 in. by 9 in.)
10	281	138X1	8	Wedge, bearing (American Car and Foundry Co., drop forged, 5 in. by 9 in.)

HAND BRAKE

Fig. No.	Ref. No.	Cat.No.	No. Required	Description
11	301	*4739629P4	1	Brake shaft, 63 1/16 in. long
11	302	*4739629P2	1	Shaft, lower
11	303	*6719324	2	Collar, shaft or extension
		*8866636P53	2	Pin, collar or shaft
11	304	*6707547	1	#Support block, shaft
11	305	*6731177G1	1	Bearing, shaft
		*N22P29032B	4	Bolt, bearing or wood floor, 1/2 in.-13, 2 in. hex. hd.
		*N22P29024B	4	Bolt, bearing or masonite floor, 1/2 in.-13, 1 1/2 in. hex. hd.
		*N203P29B	4	Nut, 1/2 in.-13
		*N405P45	4	Lock washer, 1/2 in.
11	306	*1147873P3	1	Ratchet, shaft
		*8866636P51	1	Pin, ratchet
11	307	*1147873P2	1	Pawl
		*N22P33028	1	Bolt, pawl, 5/8 in.-11, 1 3/4 in., hex. hd.
11	310	*1147872P1	1	Hand brake
11	311	*926X61	1	Bracket

*Added or changed since last issue.

#Must be welded in position when furnished separately.

MECHANICAL PARTS OF DIESEL-ELECTRIC LOCOMOTIVE

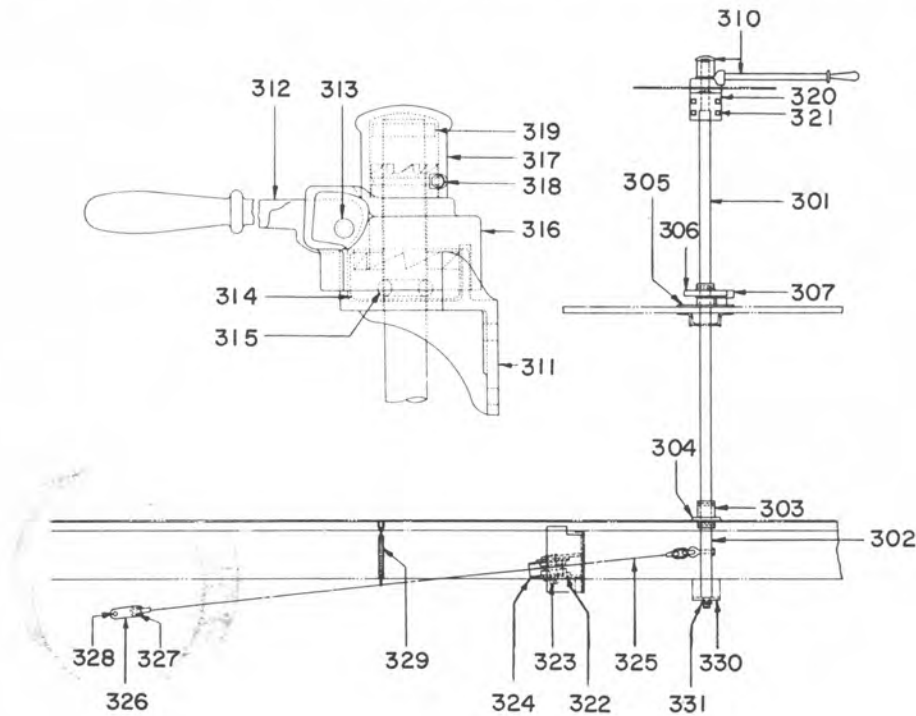

FIG. 11

Fig. No.	Ref. No.	Cat. No.	No. Required	Description
11	312	*926X62	1	Lever
11	313	*926X63	1	Lever rivet
11	314	*926X64	1	Lower ratchet, 1 1/4 in.
11	315	*8866636P55	2	Pin, lower ratchet
11	316	*926X66	1	Top ratchet, 1 1/4 in.
11	317	*926X67	1	Cap
11	318	*926X68	1	Brass rivet, cap
11	319	*8866636P27	1	Top shaft pin
		*8866636P27	1	Pin, lever or brake shaft, 1 7/8 in. long
		*8866636P55	1	Pin, lever or brake shaft, 3 1/4 in. long
11	320	*6729444G1	1	Support, bracket
11	321	*N22P25018B	4	Bolt, fastening bracket to support, 3/8 in.-16, 1 1/8 in. hex. hd.
11	321	*N405P43	4	Lock washer, 3/8 in.
11	322	*6729268P1	1	Pulley, brake chain
11	323	*2700233	1	Pin, pulley
		*N503P3332B	2	Cotter pin, 3/8 in. by 2 in.
11	324	*6729441P1	1	#Guide, brake chain
11	325	*6731263G2	1	Brake chain with eye bolt
11	326	*4733799P1	1	Clevis, brake chain
11	327	*6708325	1	Pin, clevis or brake chain
		*N503P1216B	1	Cotter pin, 1/8 in. by 1 in.
11	328	*6729357P9	1	Pin, clevis or brake lever
11	329	*169832	1	Tension spring, brake chain
		*8866493G1	1	#Guard, brake chain
11	330	*N402P50B	1	Washer, brake shaft extension
11	331	*N503P2224B	2	Cotter pin, 1/4 in. by 1 1/2 in.

*Added or changed since last issue.

#Must be welded in position when furnished separately.

LOCOMOTIVE AND CAR EQUIPMENT DEPARTMENT

GENERAL  **ELECTRIC**

ERIE, PA.

RENEWAL PARTS

CATERPILLAR D17000 DIESEL ENGINE

Manufactured by
Caterpillar Tractor Company

EFFECTIVE WITH SERIAL NUMBER 9J5144SP

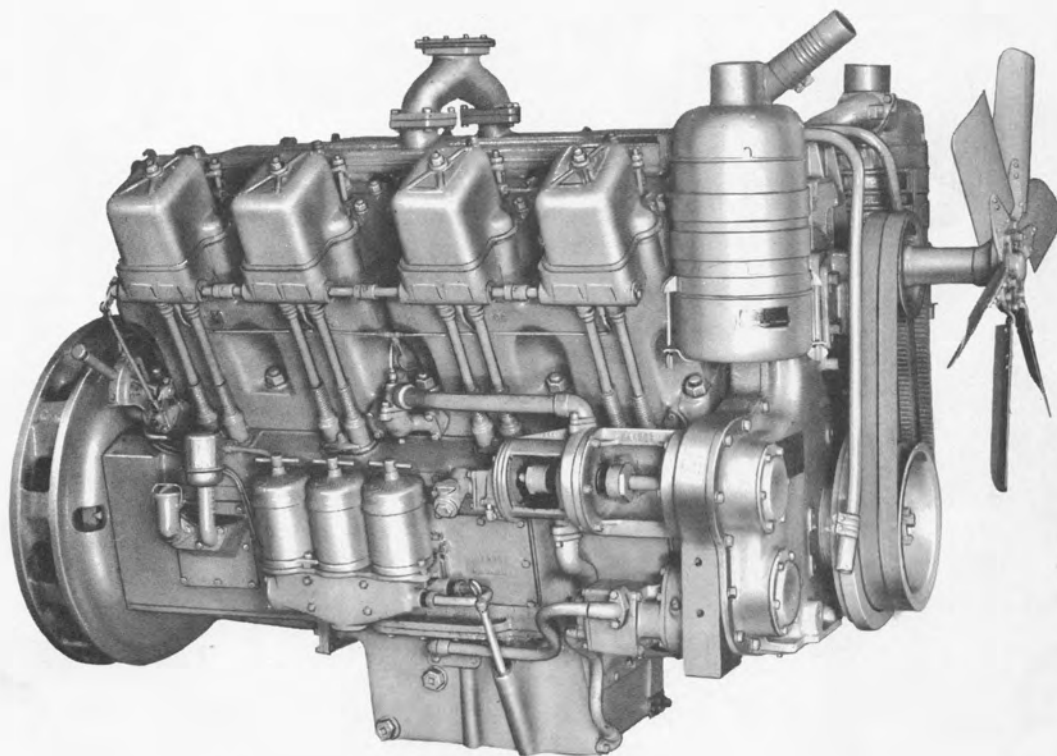

When ordering parts of engine, other than fuel injection pump, always give engine serial number stamped on nameplate located on cylinder block above fuel filter.

When ordering parts of fuel injection pump always give serial number of pump stamped on pump housing.

The right- or left-hand side of engine is determined by looking from flywheel toward the fan end.

When ordering renewal parts, give quantity, catalog number, description of each item required, and complete nameplate reading.

GENERAL  ELECTRIC

CATERPILLAR D17000 DIESEL ENGINE

TABLE OF CONTENTS

NAME	PAGE
Air Cleaner	12, 13
Accessory Idler Gear	8
Accessory Shaft and Governor	14
Breather	29
Camshaft	39
Connecting Rod and Piston	34
Crankshaft	30, 31
Crankshaft Bearings and Caps	21, 32, 33
Crankcase, Cylinder Block and Covers	15-21
Cylinder Head and Valve Mechanism	35-38
Cylinder Liner and Ring Group	13
Fan	5
Filter, Fuel	46-48
Fuel Injection Valves and Lines	51-54
Fuel Pump and Governor Control Mechanism	54, 55
Fuel Pump Housing	50
Fuel Transfer Pump Drive	44-46
Heater Connections	8
Hour Meter and Tachometer Drive	40-43
Manifolds	12
Oil Cooler	28
Oil Filter	26
Oil Lines	27
Oil Pan	22, 23
Oil Pump Lines	24, 25
Oil Pressure Shut-off Group	57
Pump, Fuel Priming	49
Pump, Oil	23, 24
Pump, Water	9-11
Safety Alarm Group	58
Safety Shut-off Arrangement	56
Timing Gear Housing	22
Transfers and Name Plates	59
Water Lines	6, 7
Water Temperature Shut-off	56

CATERPILLAR D17000 DIESEL ENGINE

GEG-3861D

Always give engine serial number when ordering parts

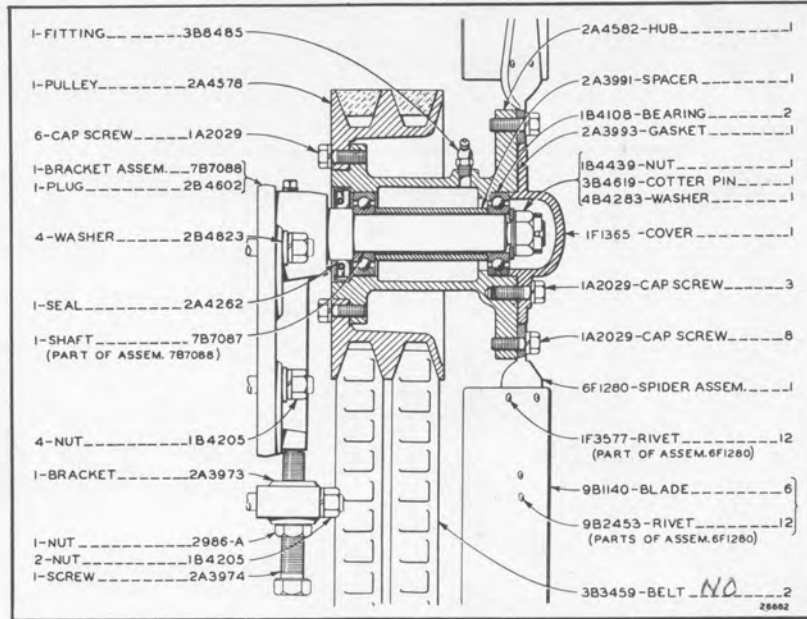

Fan

Serial No. 9J5144SP to 9J5767SP, 9J5771SP to 9J5849SP, 9J5938SP, 9J5946SP, 9J5965SP, and 9J5967SP to 9J5985SP Inclusive

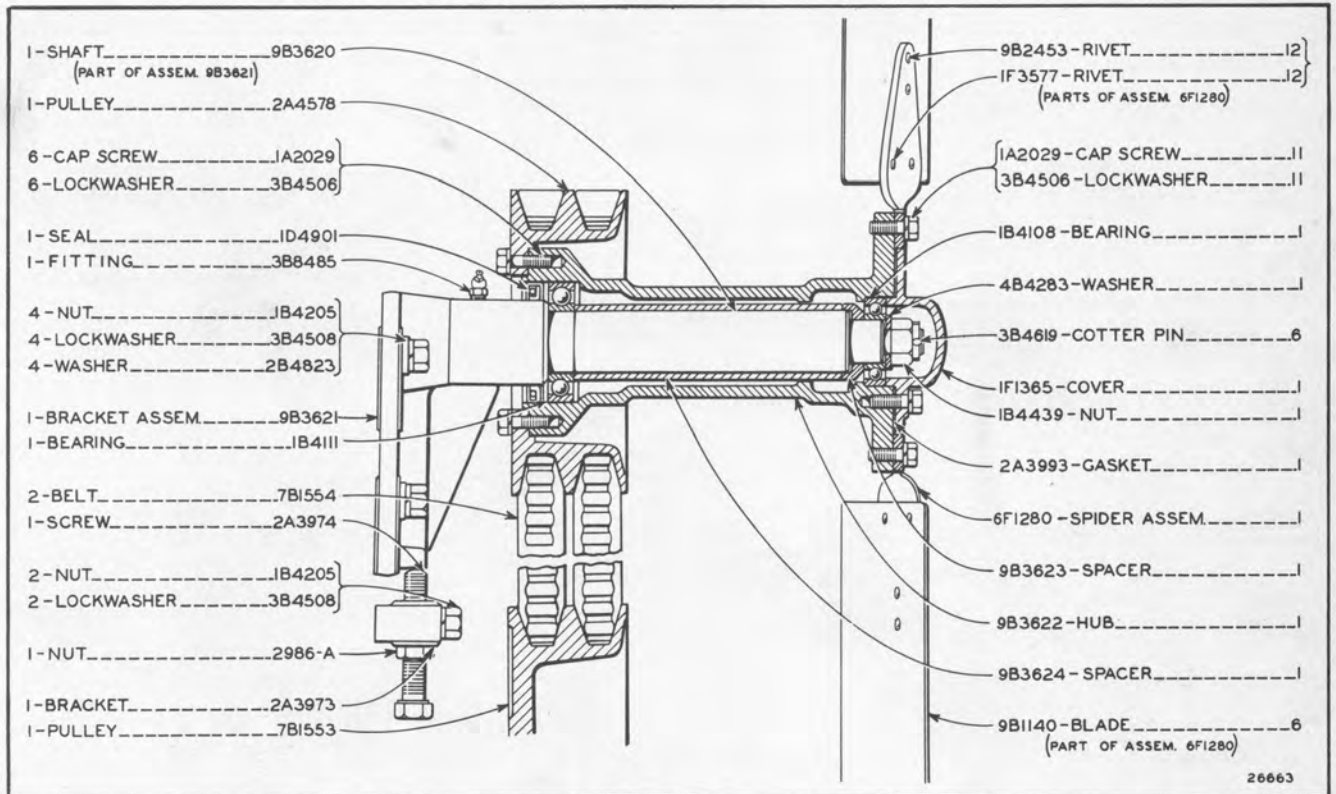

Fan

Serial No. 9J5768SP to 9J5770SP, 9J5850SP to 9J5937SP, 9J5939SP to 9J5945SP, 9J5947SP to 9J5964SP, 9J5966SP, 9J5986SP to 9J6000SP | 3S1SP to 3S2000 Inclusive and 8S5001-Up

CATERPILLAR D17000 DIESEL ENGINE

Always give engine serial number when ordering parts

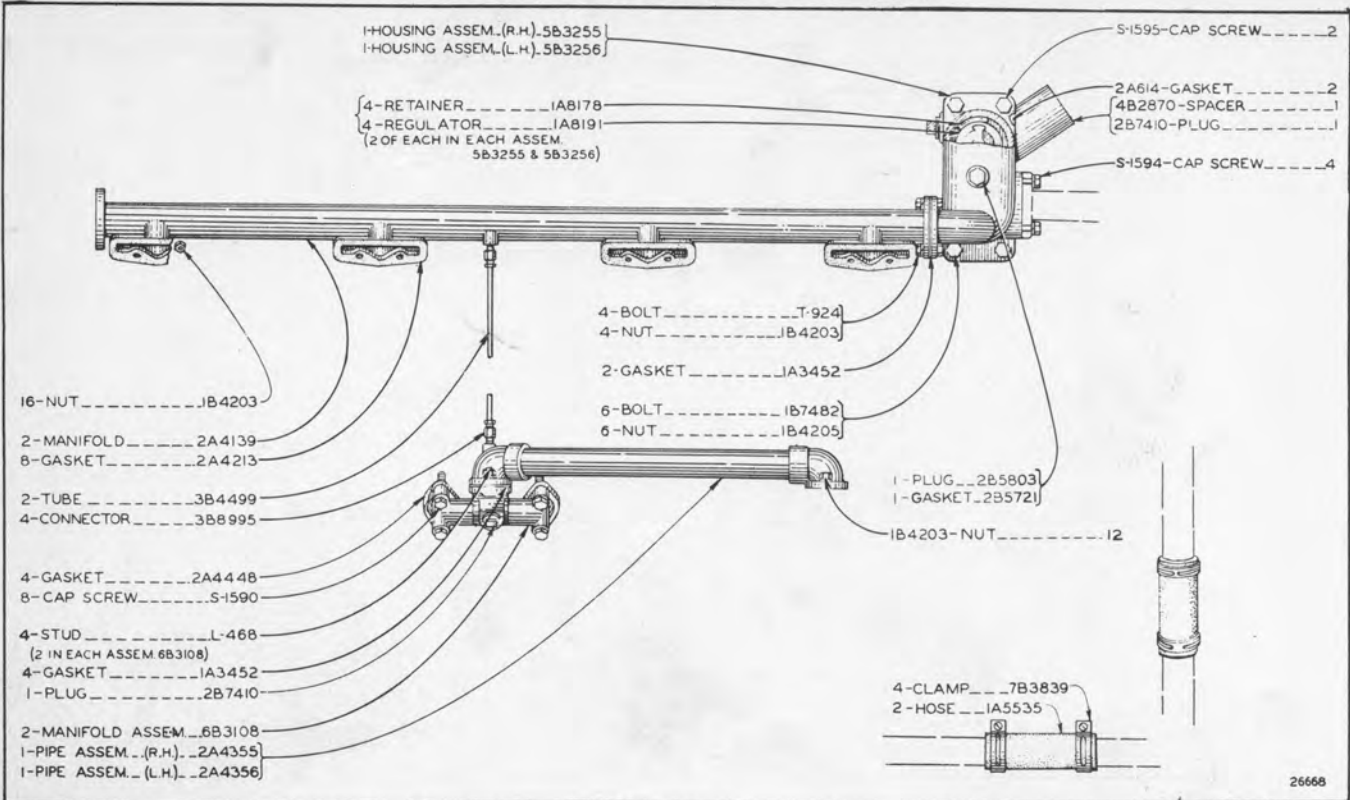

Water Lines

Serial No. 9J5144SP to 9J5213SP Inclusive

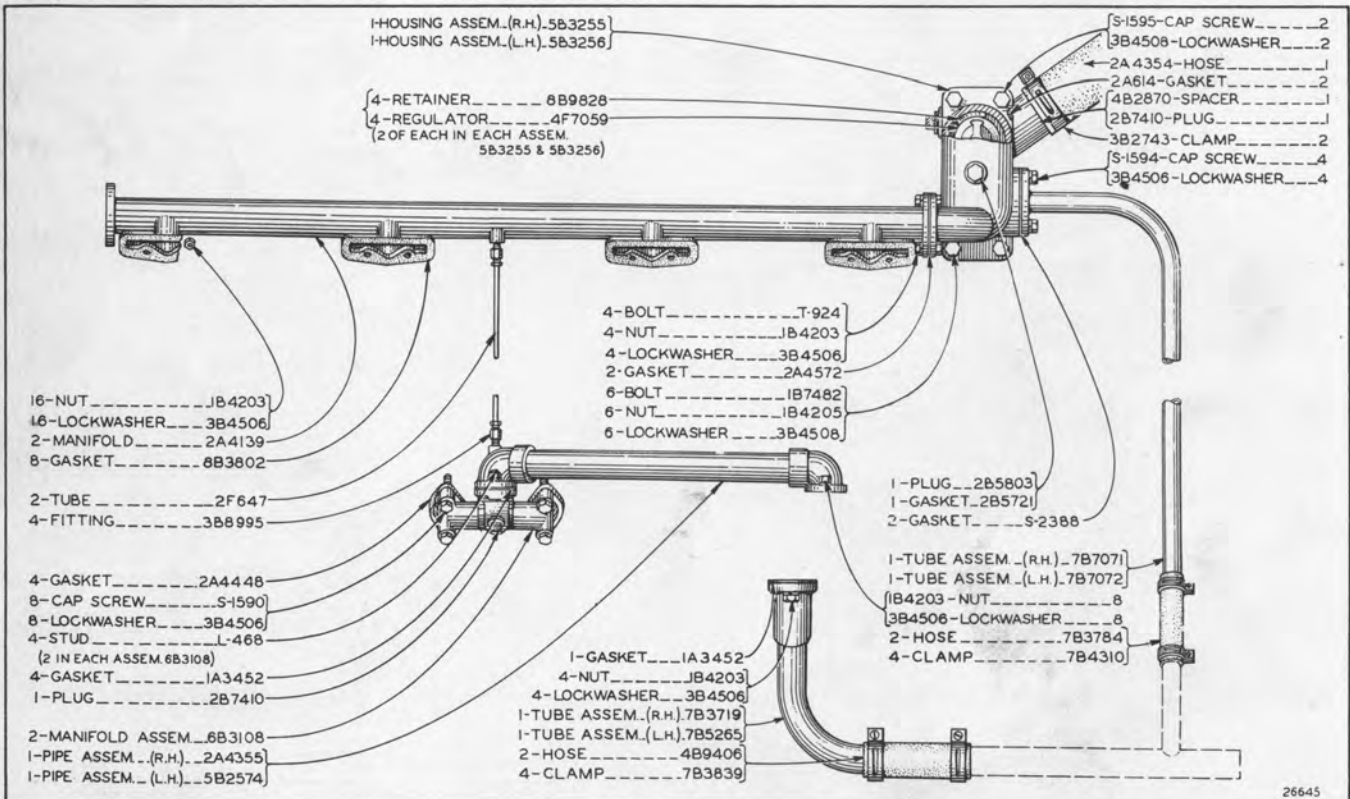

Water Lines

Serial No. 9J5214SP to 9J5364SP Inclusive

CATERPILLAR D17000 DIESEL ENGINE

GEG-3861D

Always give engine serial number when ordering parts

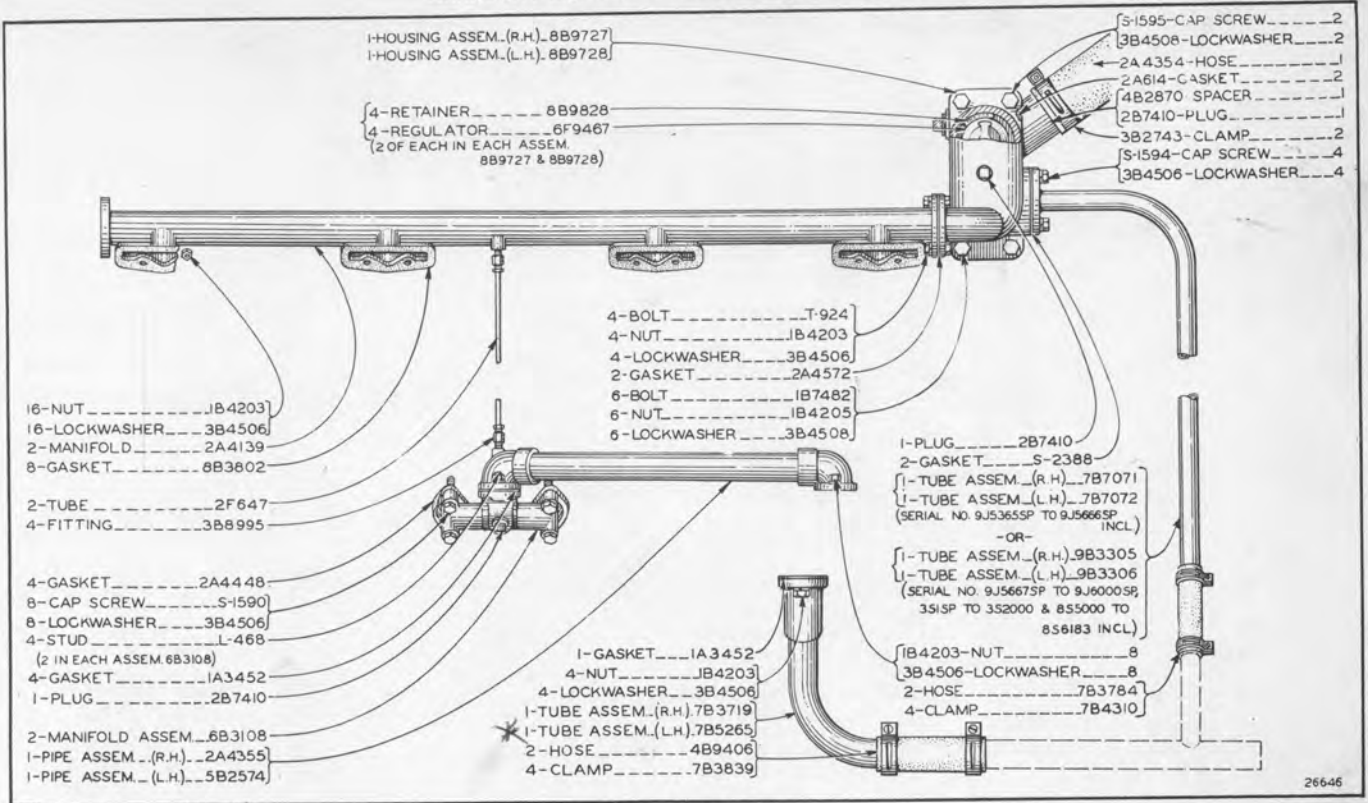

Water Lines

Serial No. 9J5365SP to 9J6000SP 3S1SP to 3S2000 and 8S5001 to 8S6183 Inclusive

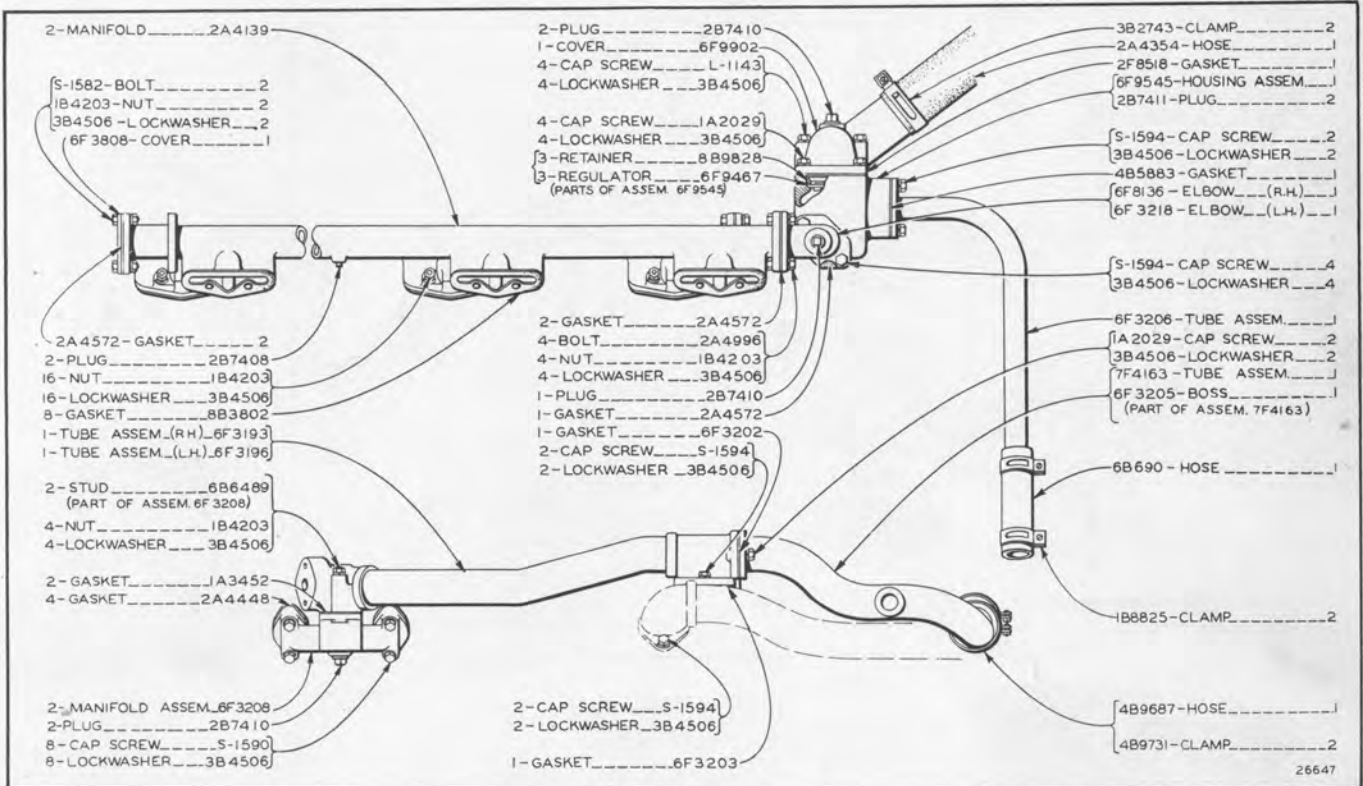

Water Lines

Effective with Serial No. 8S6184

* 7B5265 Tube Assem. Discontinued

CATERPILLAR D17000 DIESEL ENGINE

Always give engine serial number when ordering parts

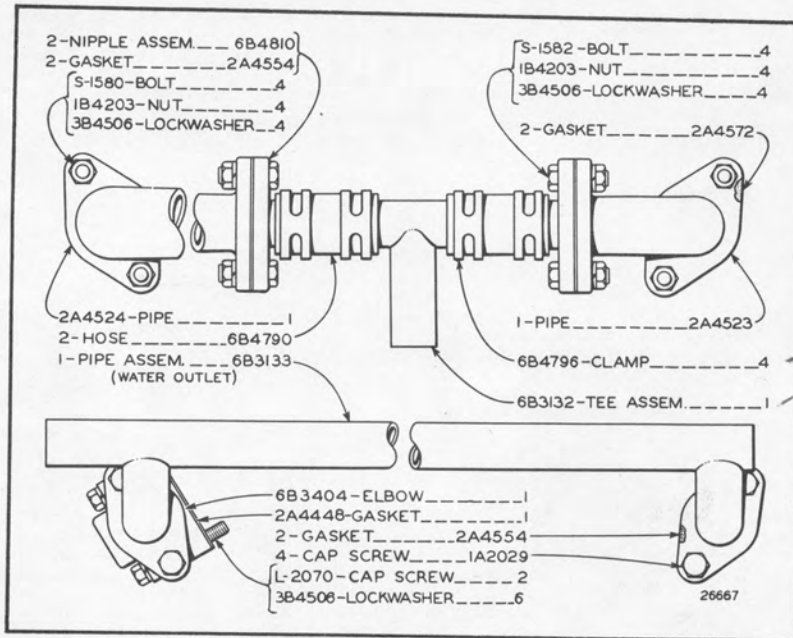

Heater Connections

Serial No. 9J5144SP to 9J6000SP, 3S1SP to 3S2000 and 8S5001 to 8S6183 Inclusive

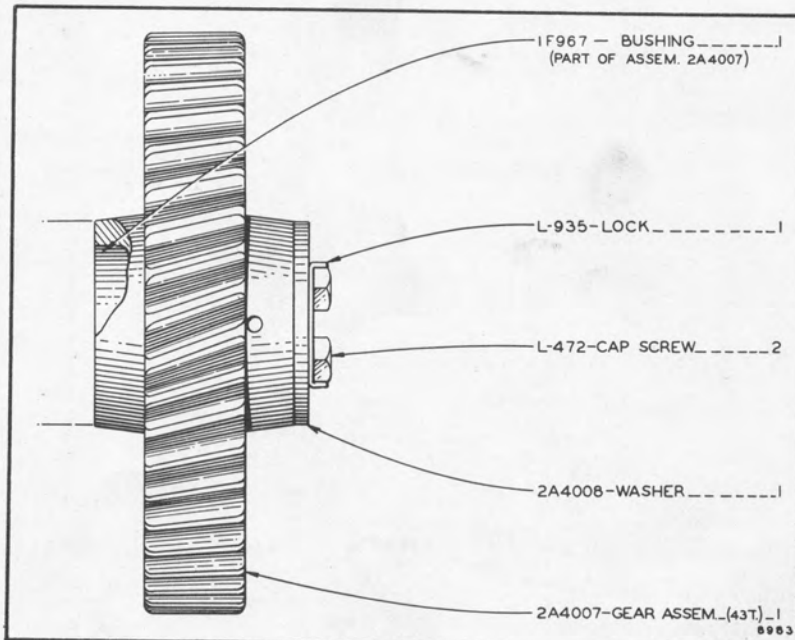

Accessory Idler Gear

CATERPILLAR D17000 DIESEL ENGINE

GEG-3861D

Always give engine serial number when ordering parts

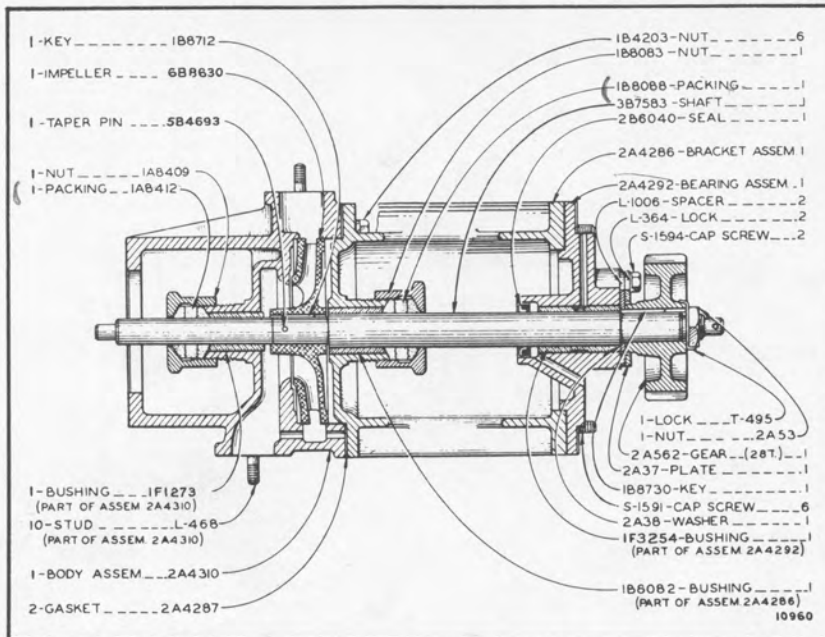

Water Pump—R. H.

Serial No. 9J5144SP to 9J6000SP, 3S1SP to 3S2000 and 8S5001 to 8S5701 Inclusive

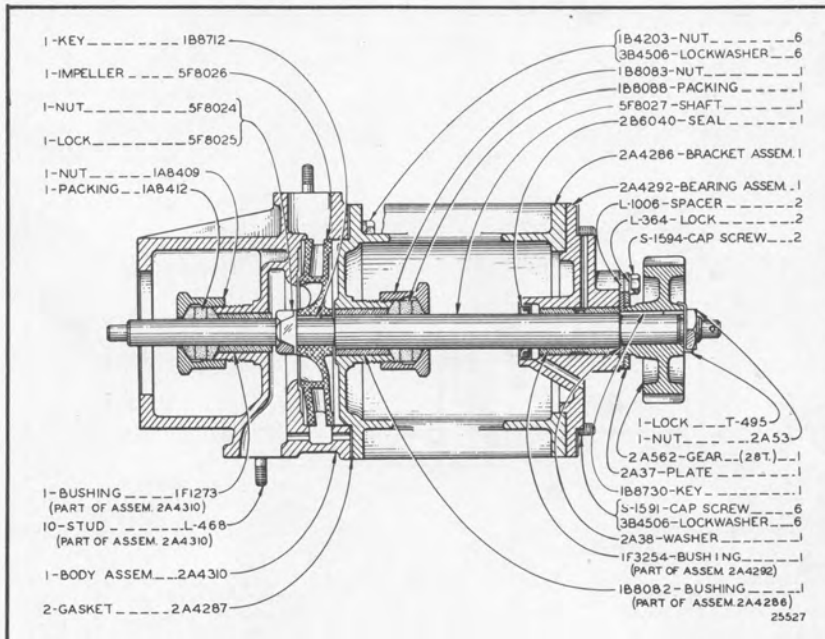

Water Pump—R. H.

Serial No. 8S5702 to 8S6183 Inclusive

CATERPILLAR D17000 DIESEL ENGINE

Always give engine serial number when ordering parts

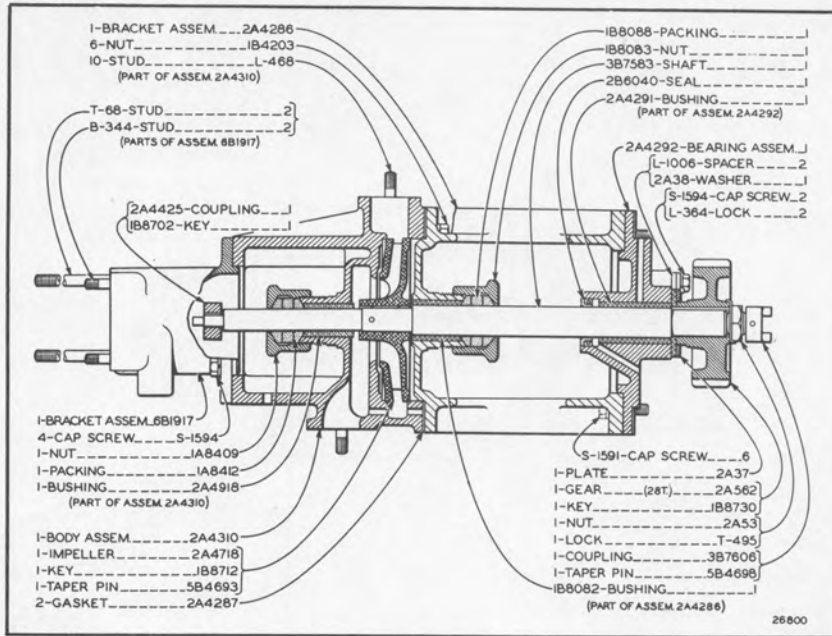

Water Pump—L. H.
Serial No. 9J5144SP to 9J5213SP Inclusive

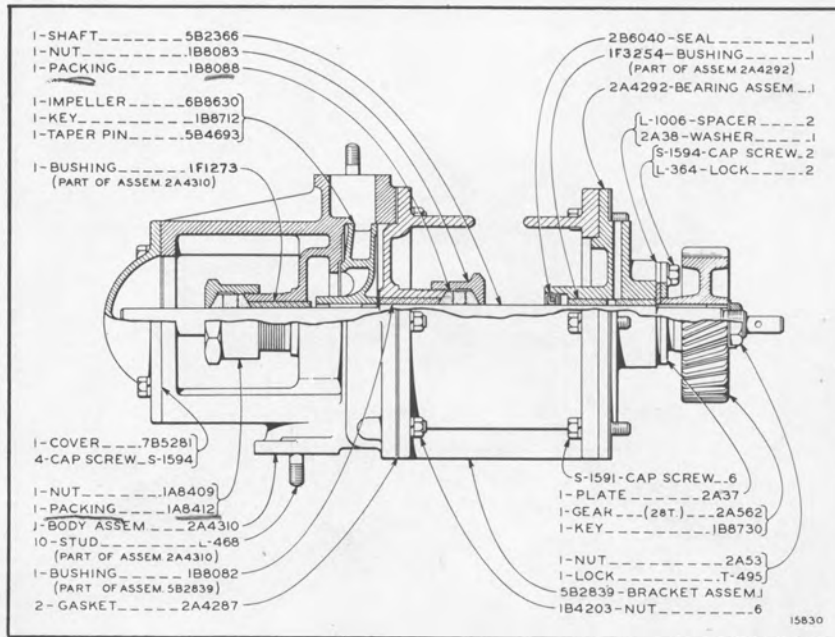

Water Pump—L. H.
Serial No. 9J5214SP to 9J6000SP, 3S1SP to 3S2000 and 8S5001 to 8S5701 Inclusive

CATERPILLAR D17000 DIESEL ENGINE

GEG-3861D

Always give engine serial number when ordering parts

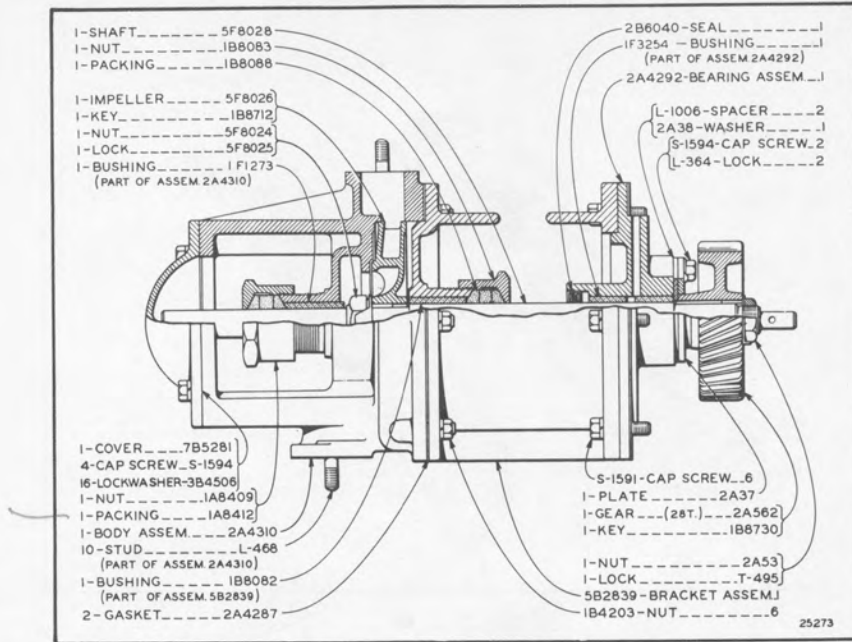

Water Pump—L. H.
 Serial No. 8S5702 to 8S6183 Inclusive

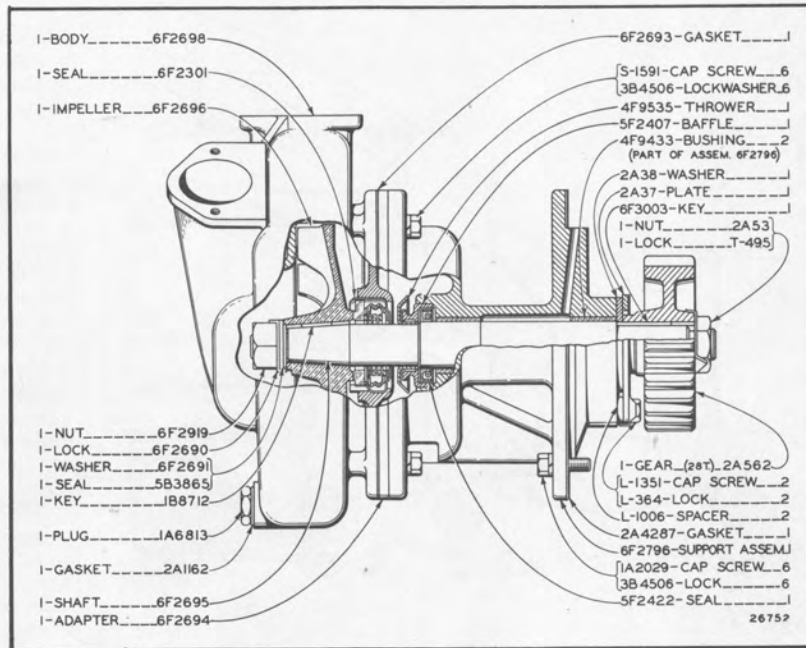

Water Pump
 Effective with Serial No. 8S6184

CATERPILLAR D17000 DIESEL ENGINE

Always give engine serial number when ordering parts

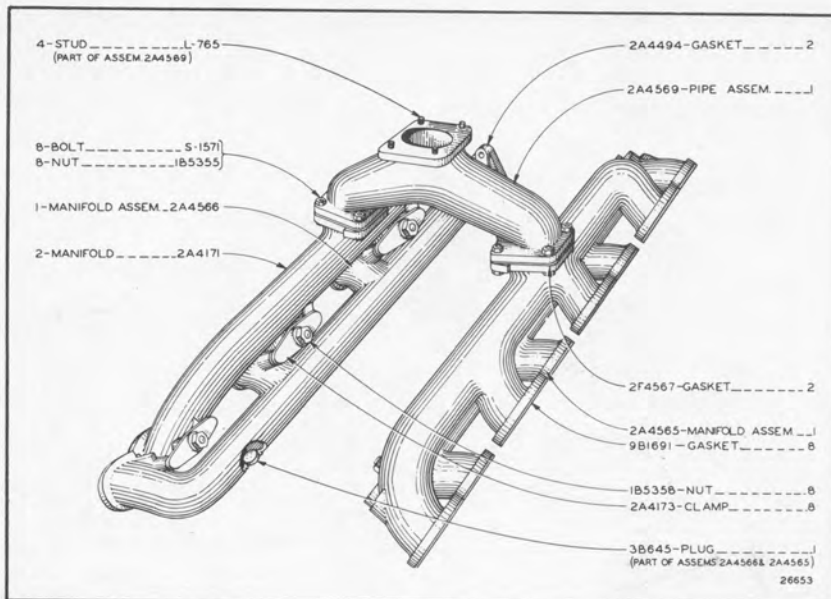

Manifolds

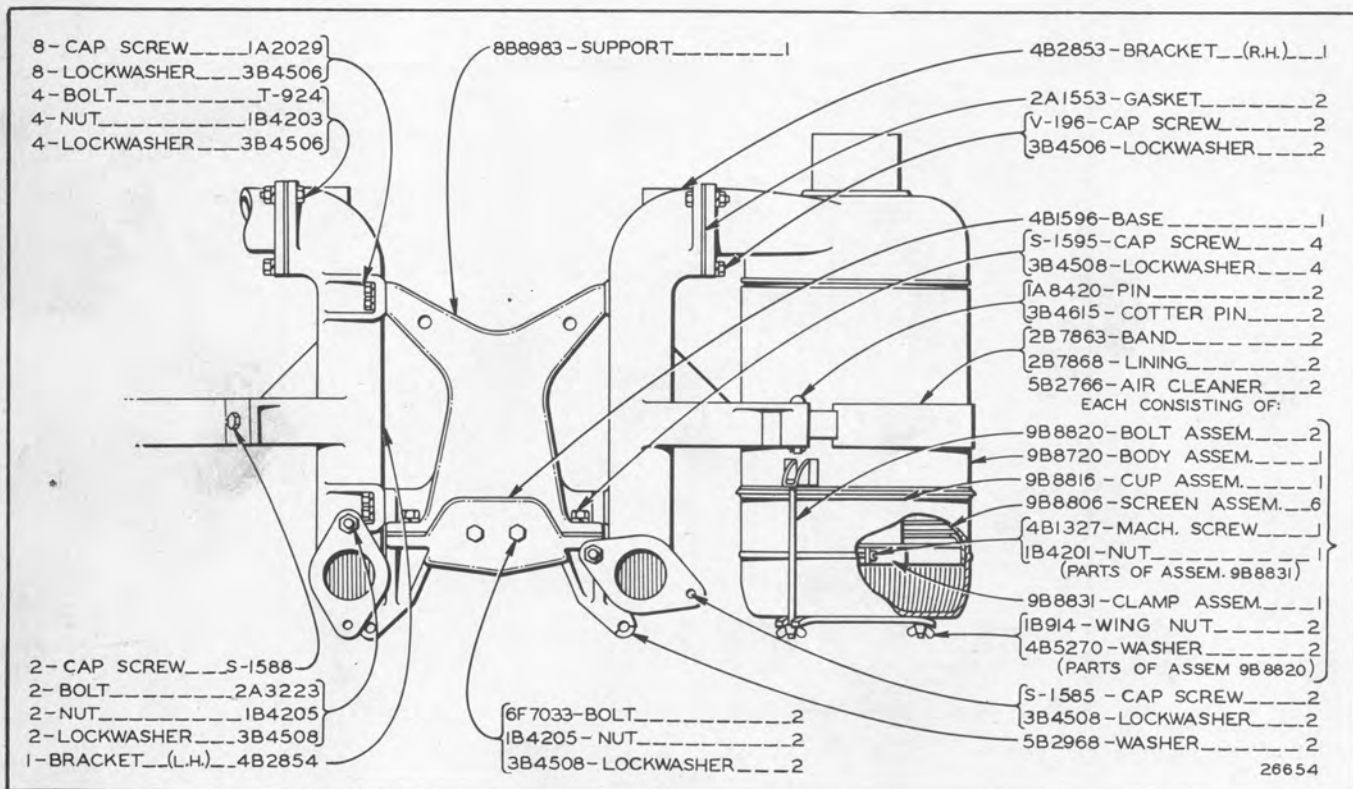

Air Cleaners

Serial No. 9J5144SP to 9J5213SP Inclusive

CATERPILLAR D17000 DIESEL ENGINE

GEG-3861D

Always give engine serial number when ordering parts

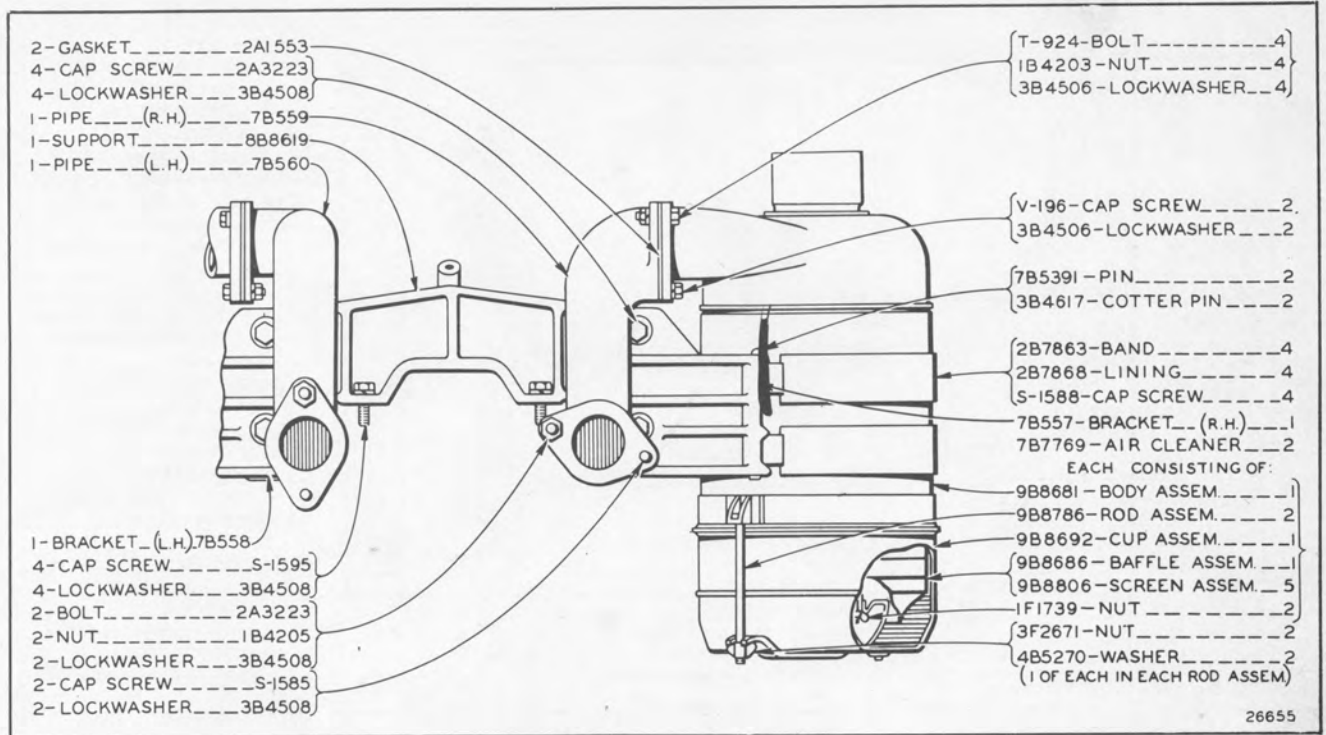

Air Cleaners

Serial No. 9J5214SP to 9J6000SP, 3S1SP to 3S2000 Inclusive and 8S5001-Up

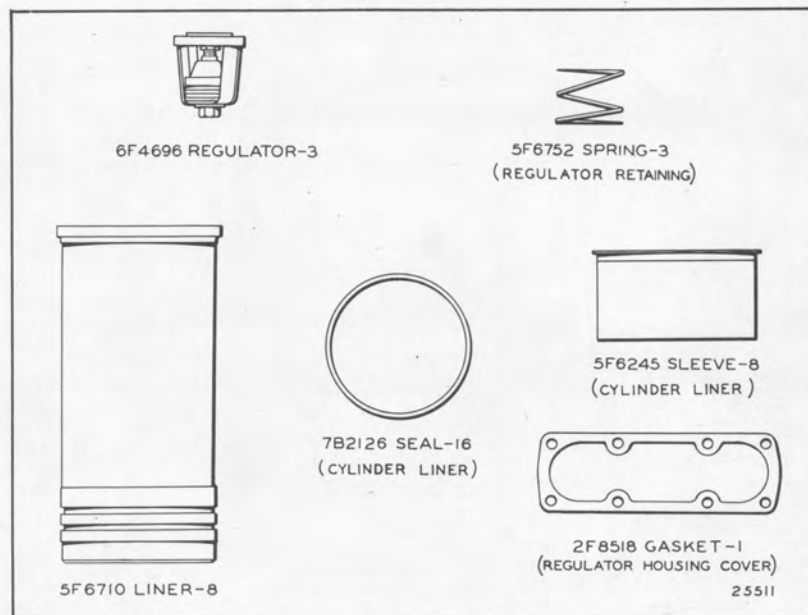

6F5252 Cylinder Liner and Ring Group

Effective with Serial No. 8S6184

CATERPILLAR D17000 DIESEL ENGINE

Always give engine serial number when ordering parts

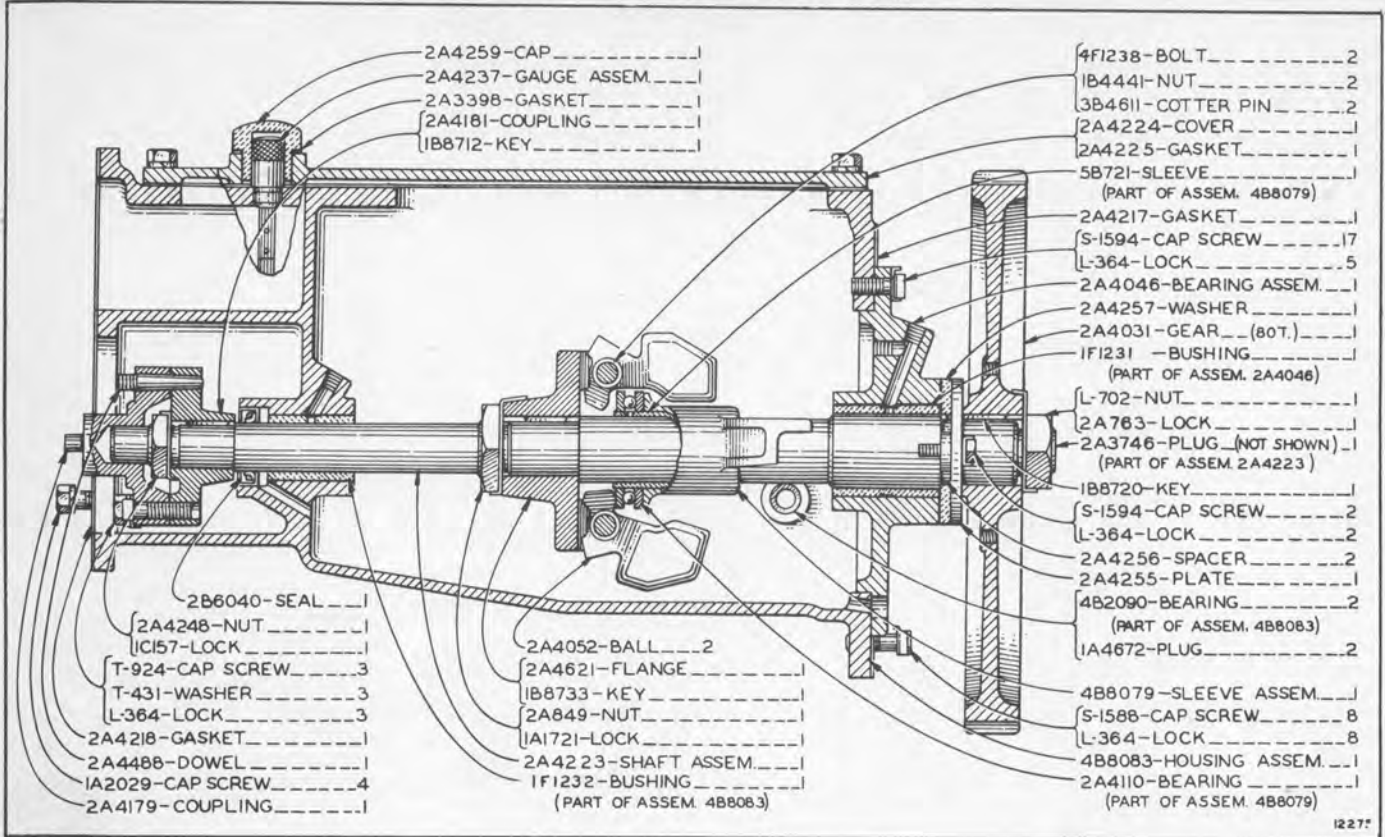

1227

Accessory Shaft and Governor
 Serial No. 9J5144SP to 9J5158SP Inclusive

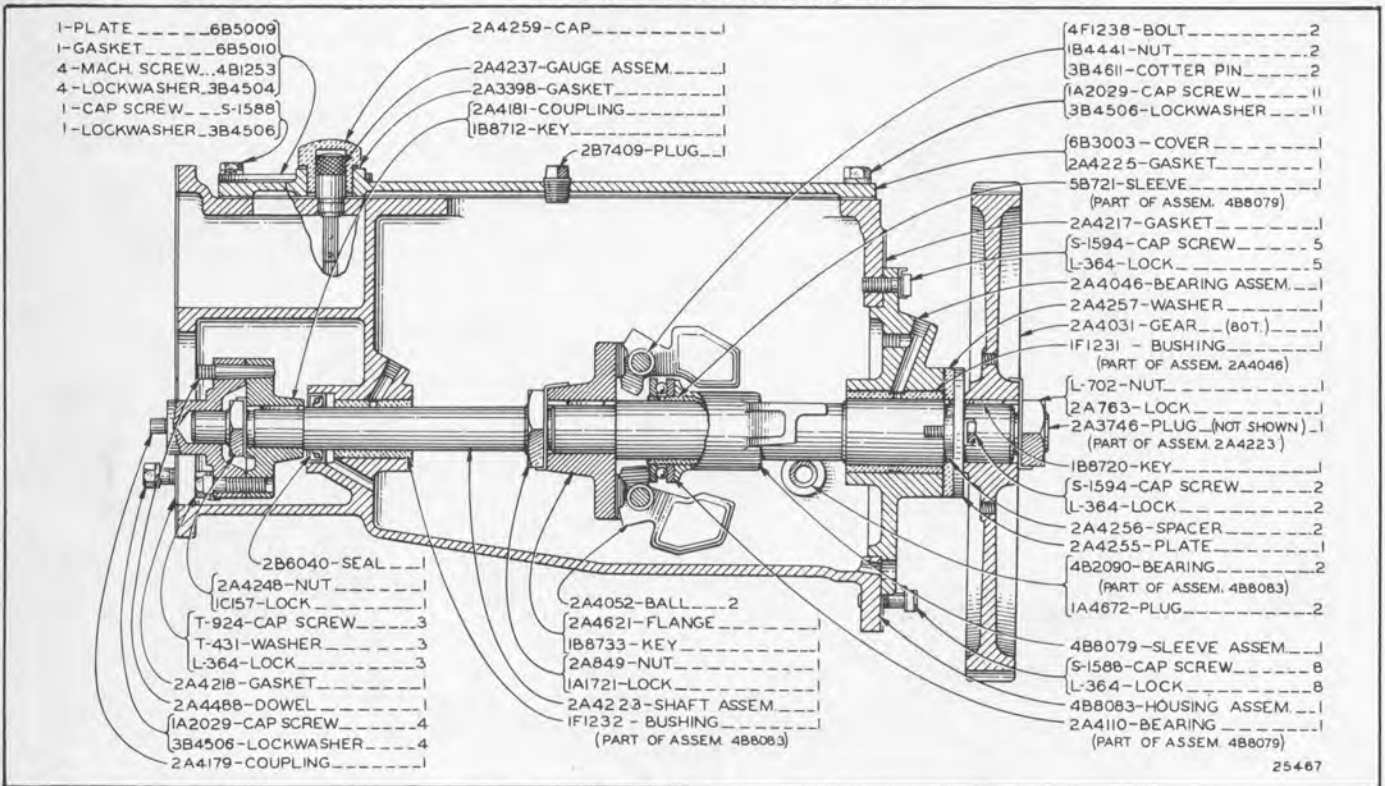

25467

Accessory Shaft and Governor
 Serial No. 9J5159SP to 9J6000SP, 3S1SP to 3S2000 Inclusive and 8S5001-Up

CATERPILLAR D17000 DIESEL ENGINE

GEG-3861D

Always give engine serial number when ordering parts

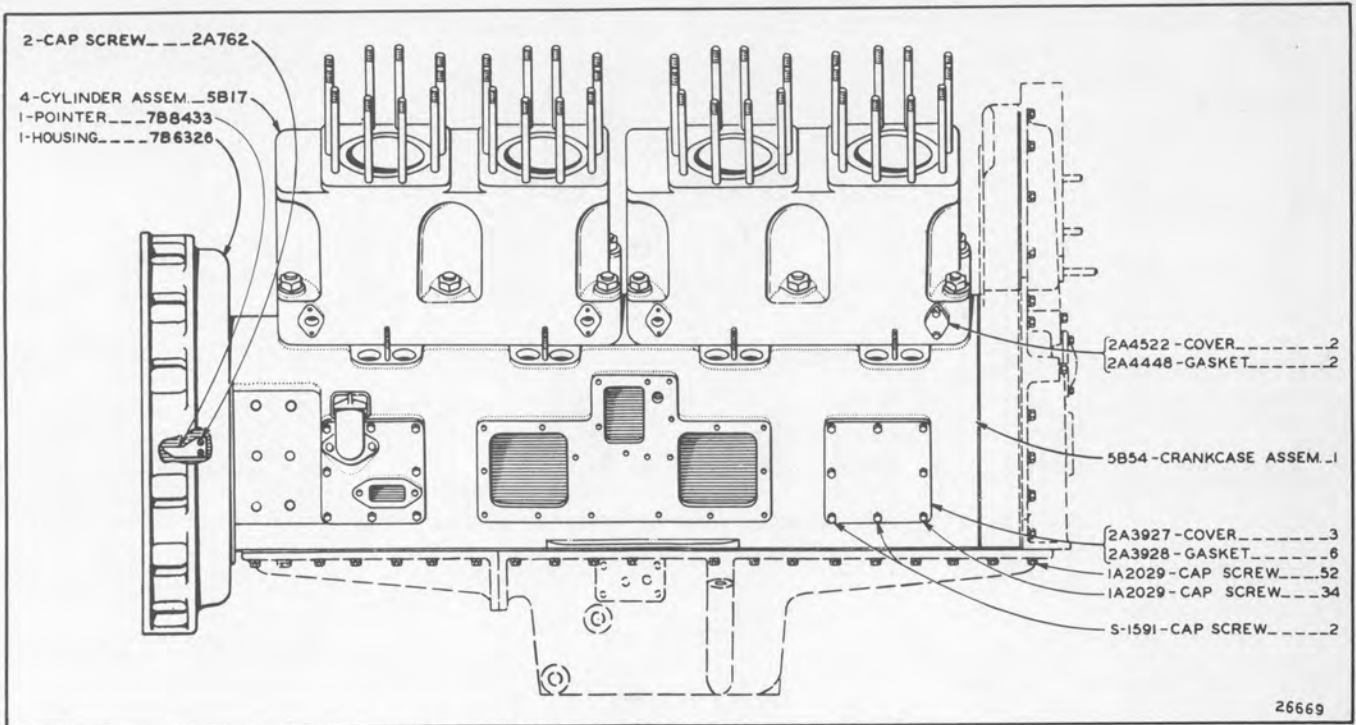

Crankcase, Cylinder Block and Covers—Side View
Serial No. 9J5144SP to 9J5213SP Inclusive

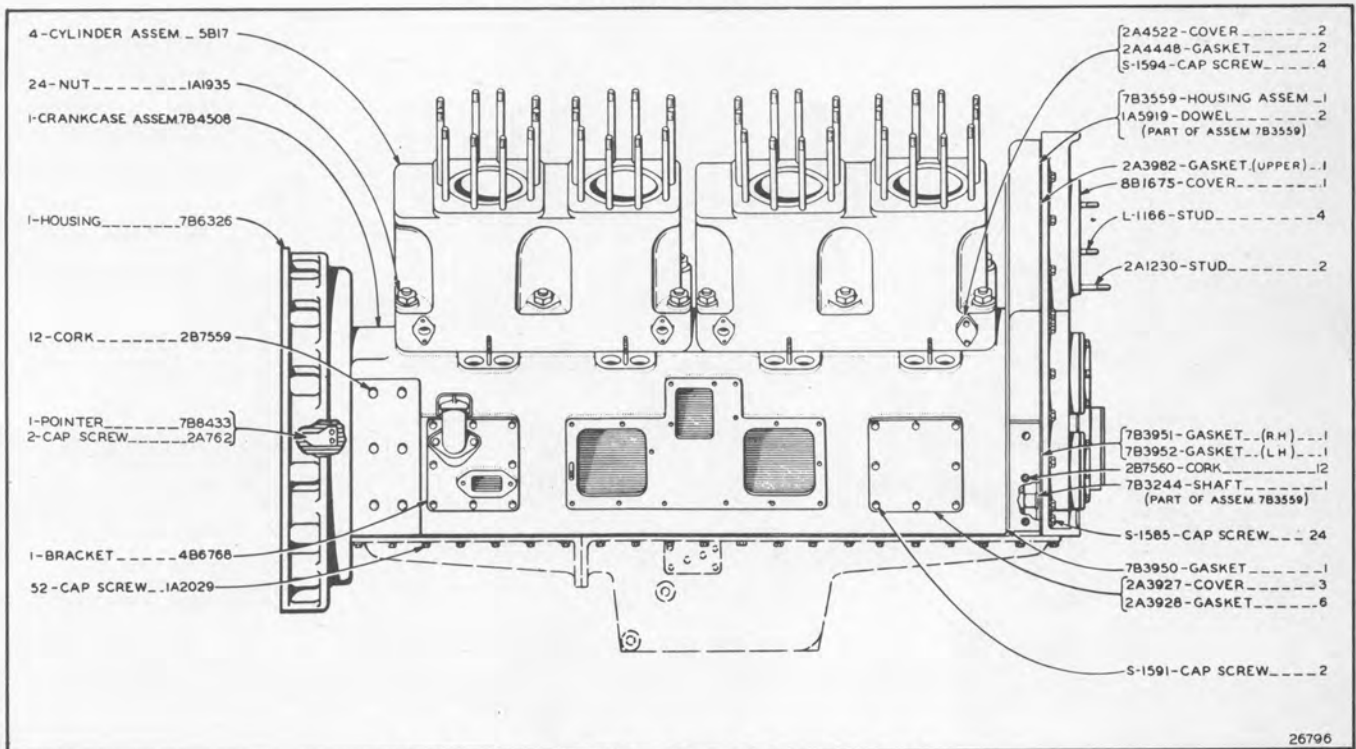

Crankcase, Cylinder Block and Covers—Side View
Serial No. 9J5214SP to 9J5267SP Inclusive

CATERPILLAR D17000 DIESEL ENGINE

Always give engine serial number when ordering parts

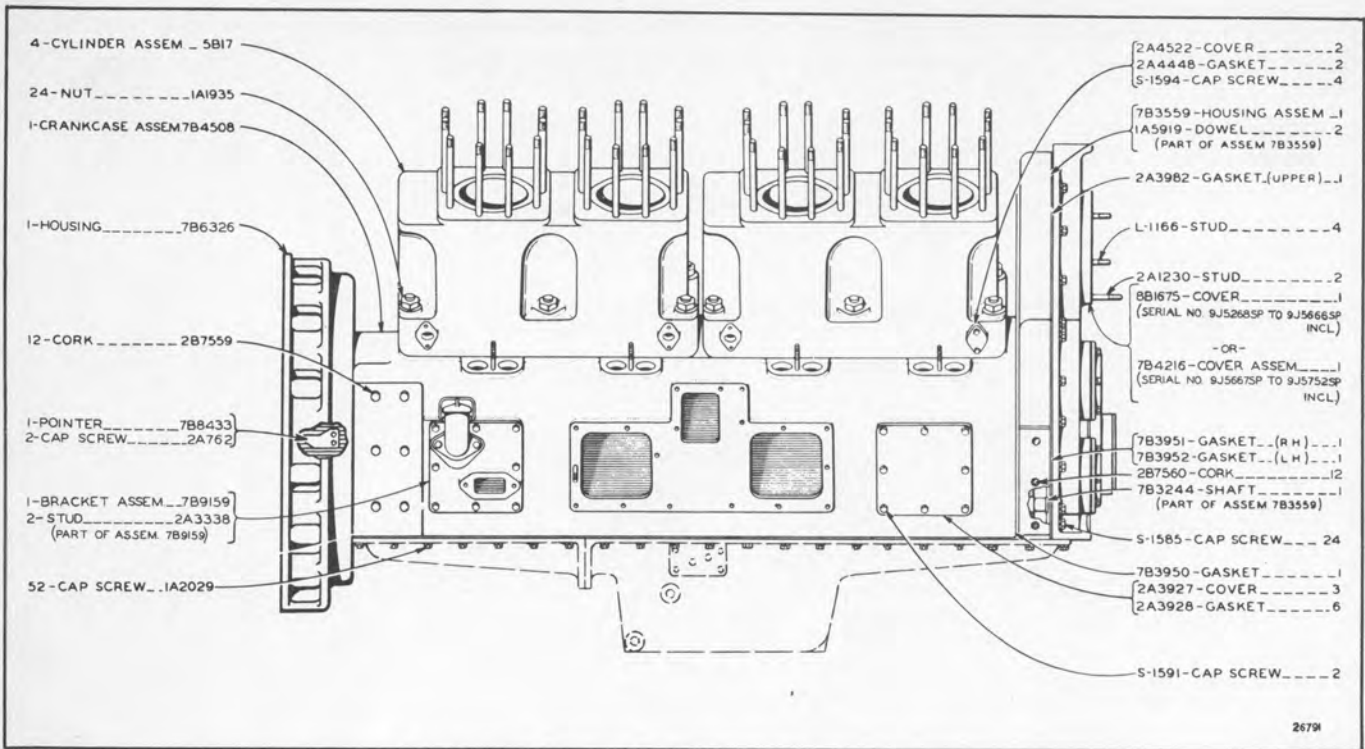

Crankcase, Cylinder Block and Covers—Side View
Serial No. 9J5268SP to 9J5752SP Inclusive

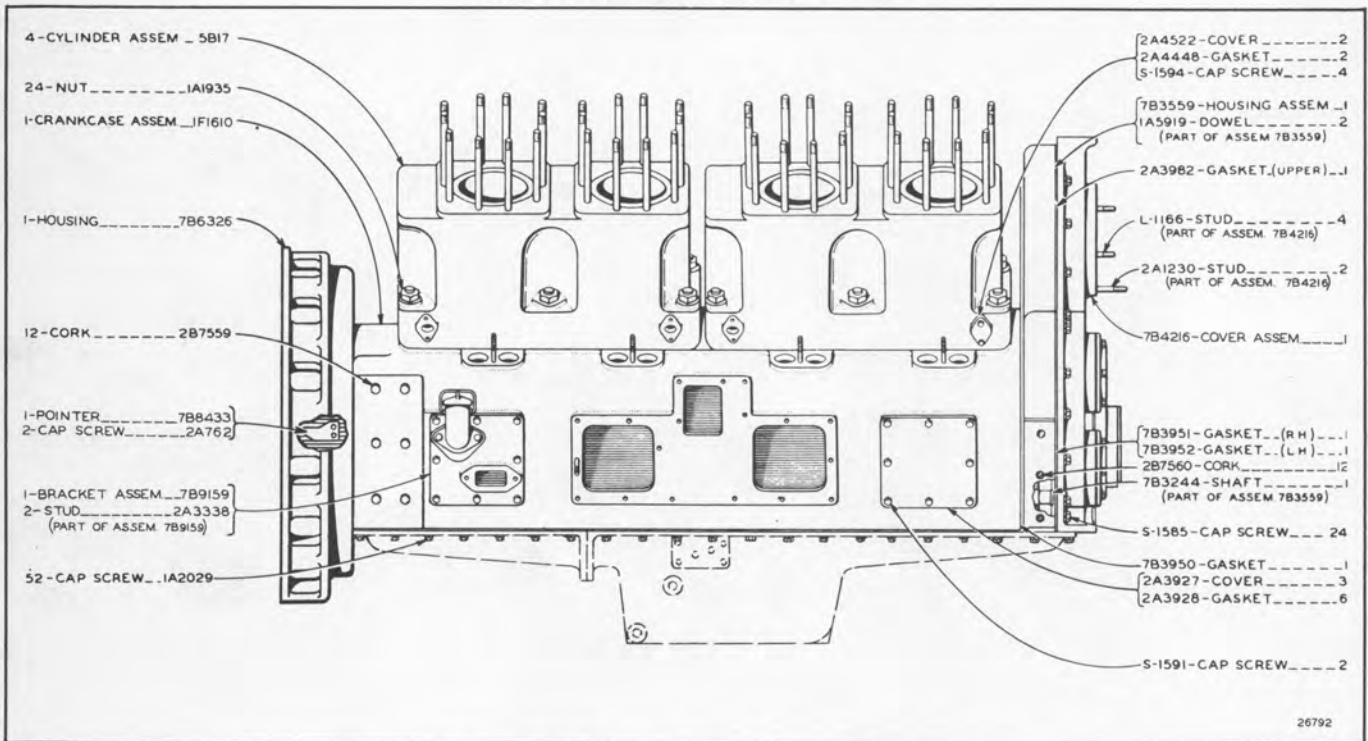

Crankcase, Cylinder Block and Covers—Side View
Serial No. 9J5753SP to 9J6000SP and 3S1SP to 3S1856 Inclusive

CATERPILLAR D17000 DIESEL ENGINE

GEG-3861D

Always give engine serial number when ordering parts

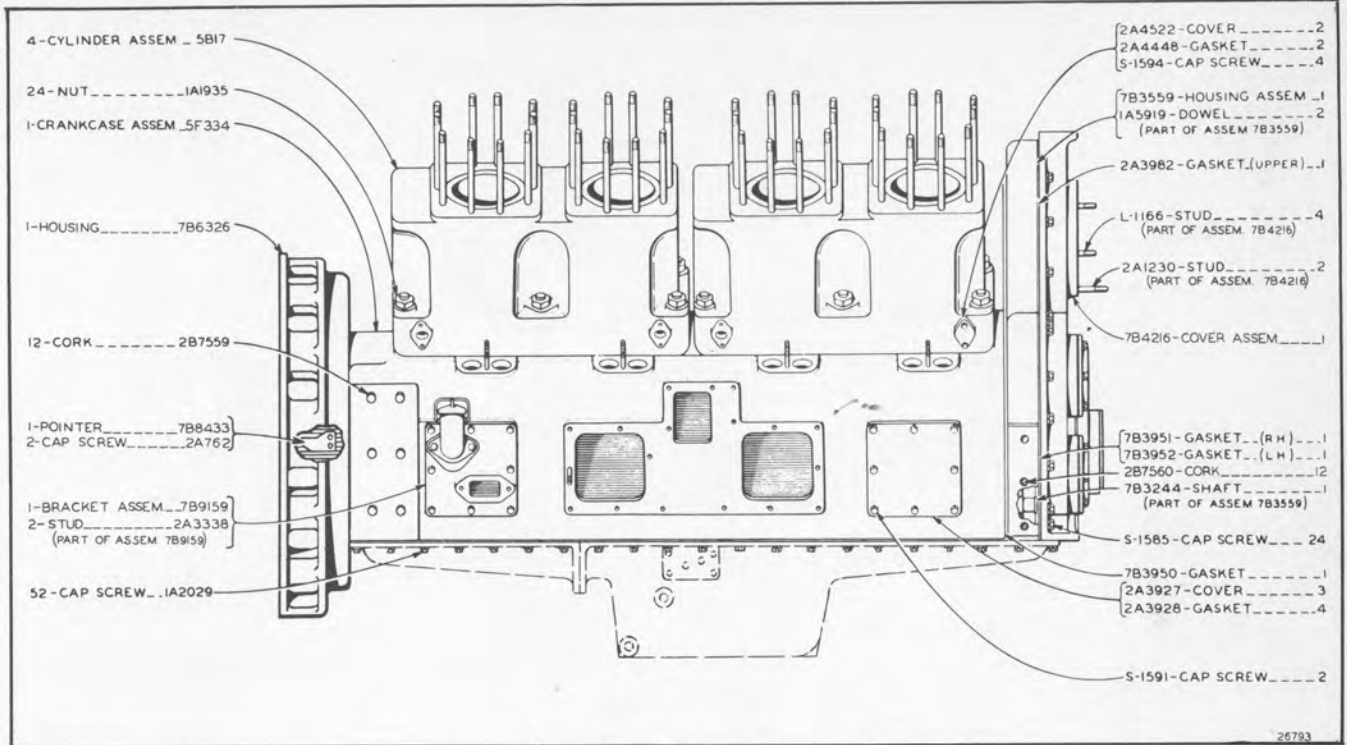

Crankcase, Cylinder Block and Covers—Side View
 Serial No. 3S1857 to 3S2000 and 8S5001 to 8S6183 Inclusive

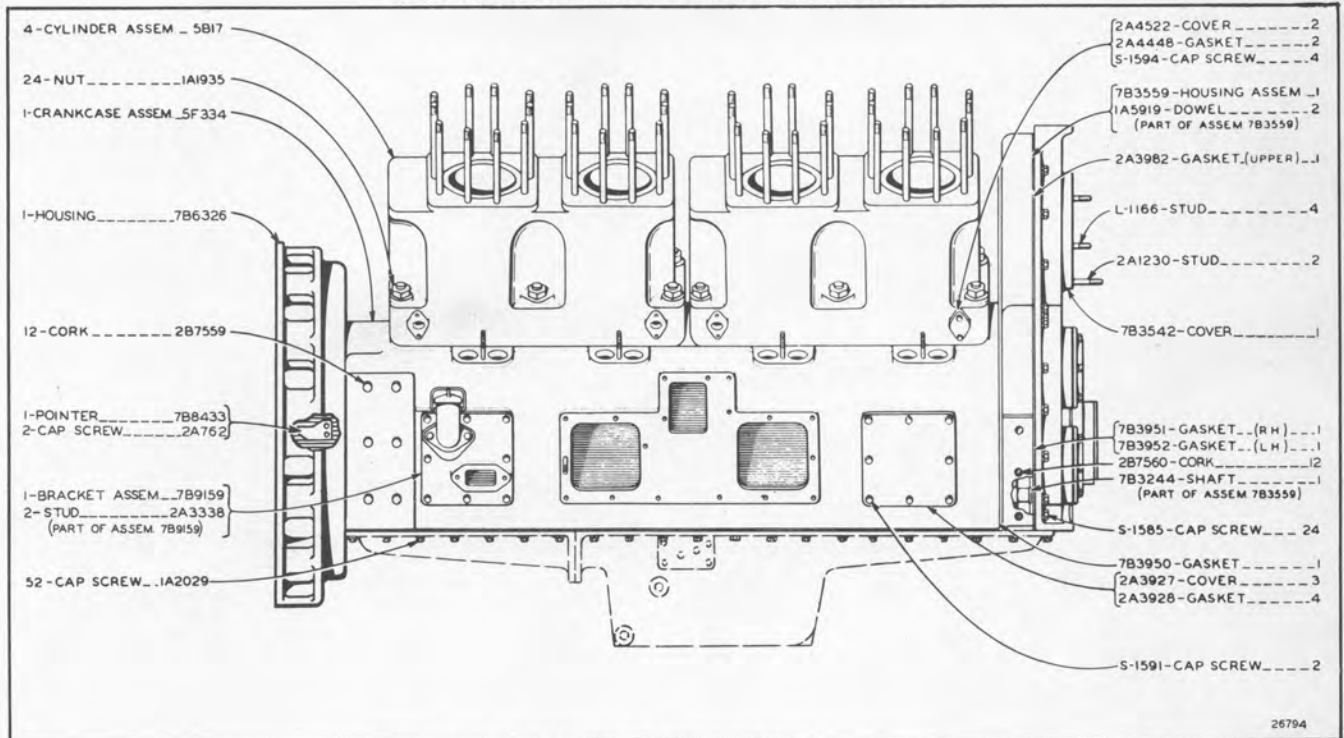

Crankcase, Cylinder Block and Covers—Side View
 Effective with Serial No. 8S6184

CATERPILLAR D17000 DIESEL ENGINE

Always give engine serial number when ordering parts

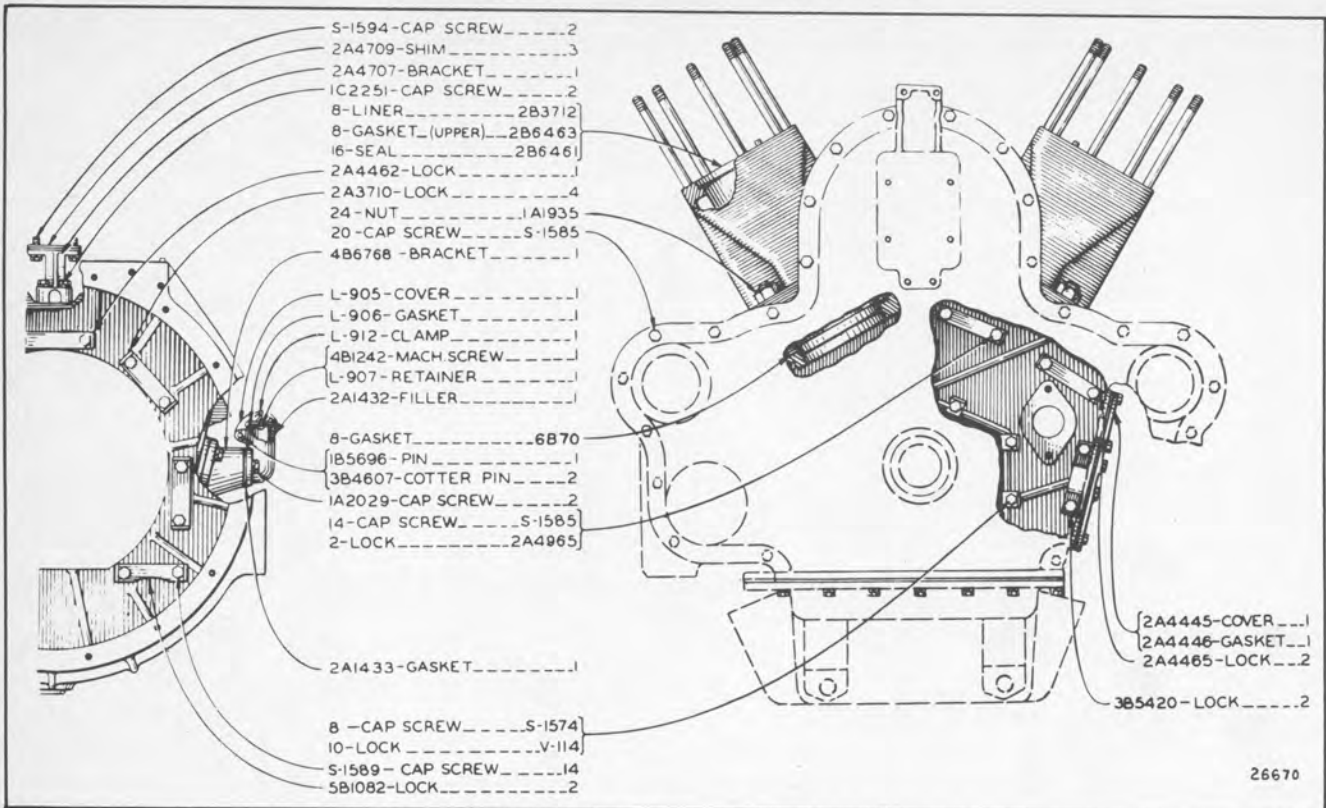

Crankcase, Cylinder Block and Covers—End View

Serial No. 9J5144SP to 9J5213SP Inclusive

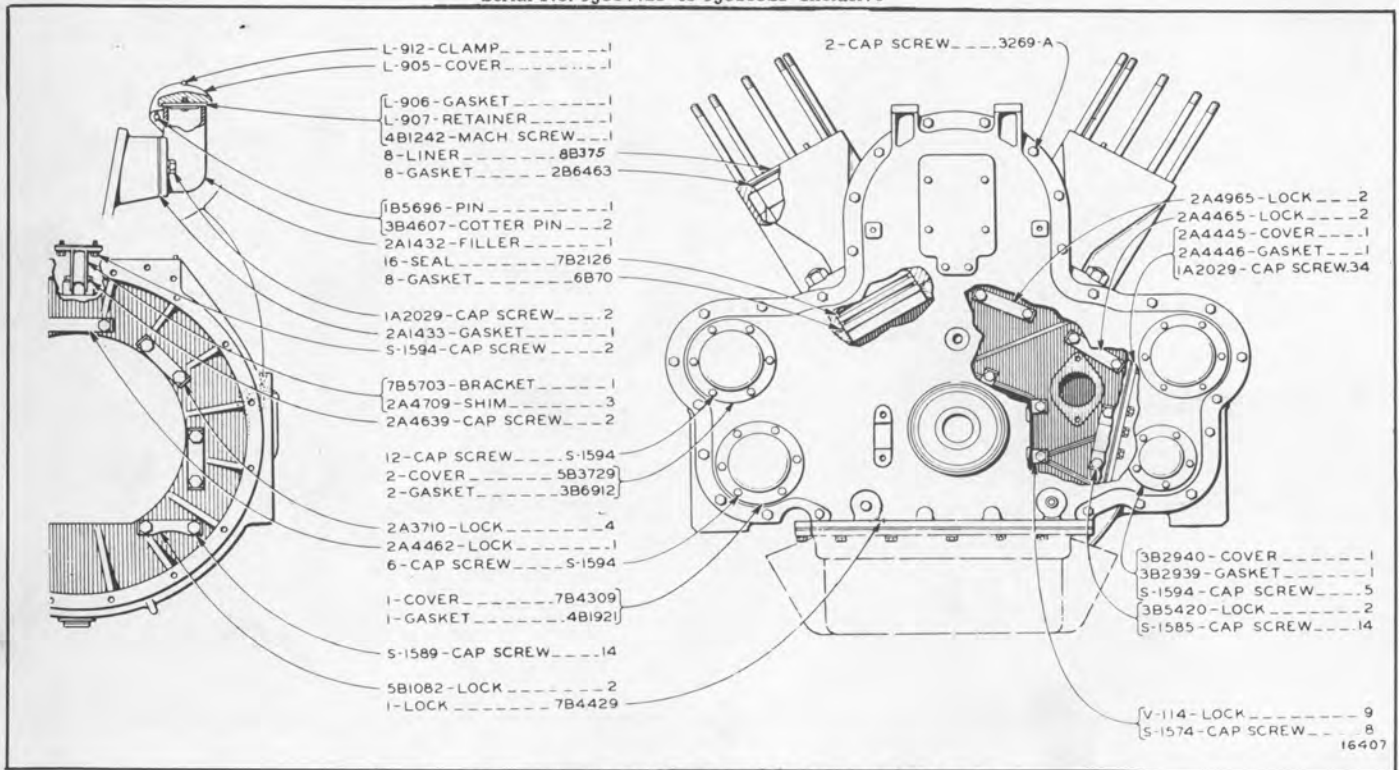

Crankcase, Cylinder Block and Covers—End View

Serial No. 9J5214SP to 9J6000SP, 3S1SP to 3S2000 and 8S5001 to 8S6183 Inclusive

CATERPILLAR D17000 DIESEL ENGINE

GEG-3861D

Always give engine serial number when ordering parts

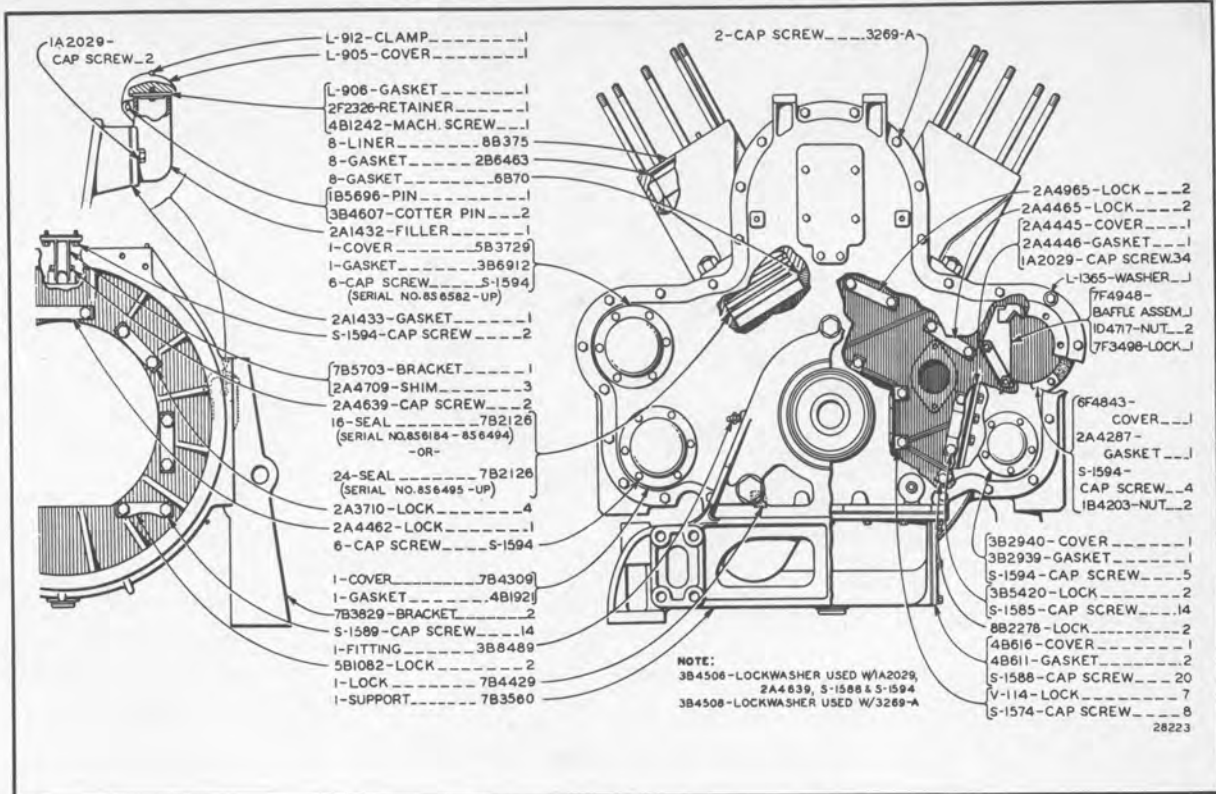

Crankcase, Cylinder Block and Covers—End View
 Effective with Serial No. 8S6184

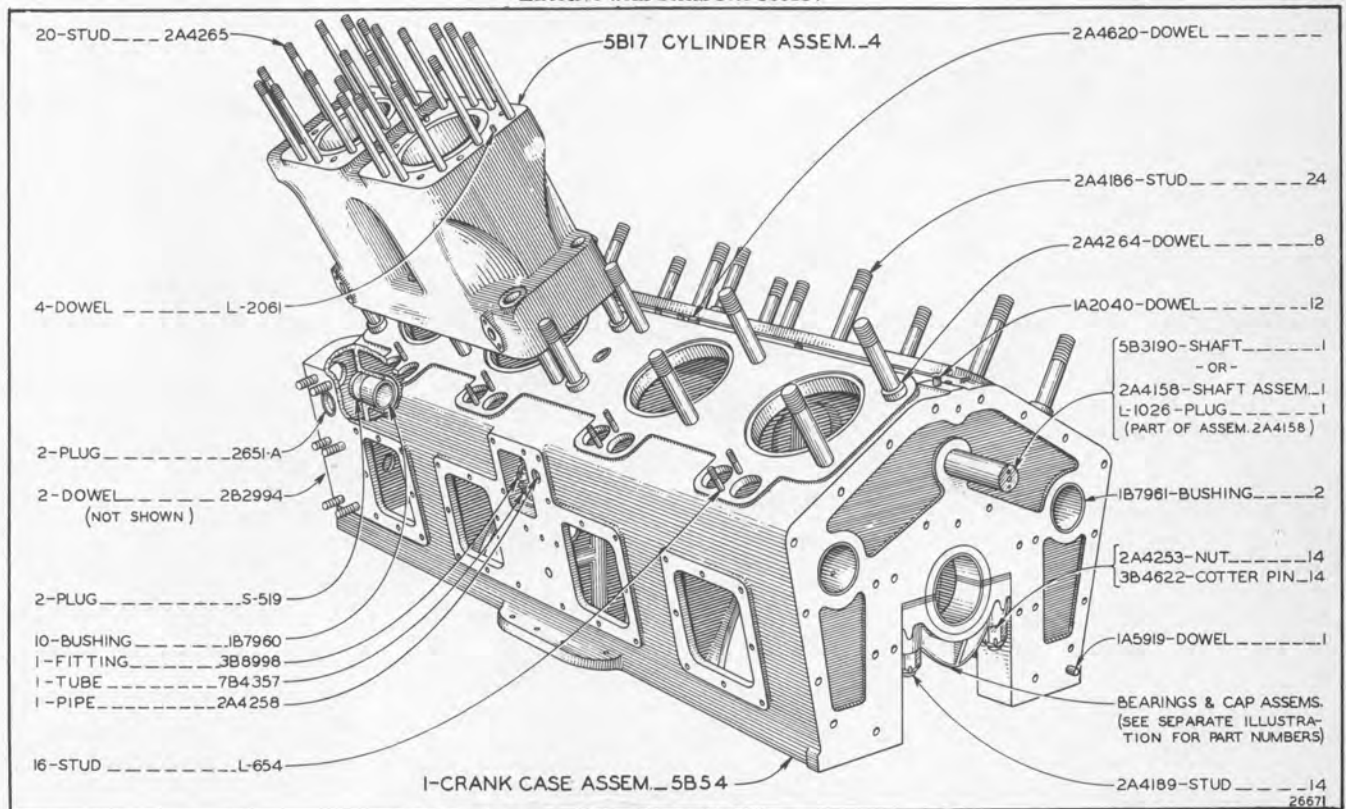

Crankcase and Cylinder Block Assemblies
 Serial No. 9J5144SP to 9J5213SP Inclusive

CATERPILLAR D17000 DIESEL ENGINE

Always give engine serial number when ordering parts

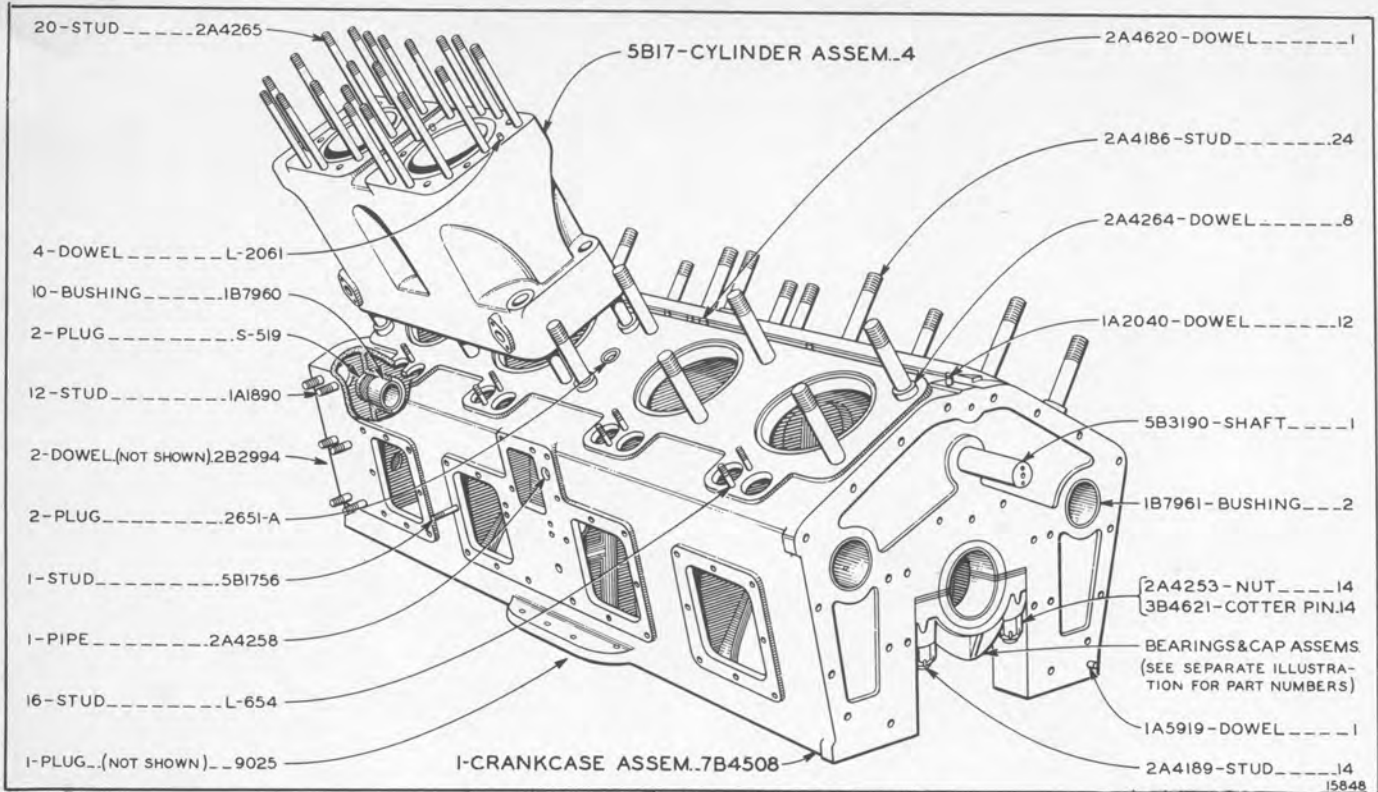

Crankcase and Cylinder Block Assemblies

Serial No. 9J5214SP to 9J5752SP Inclusive

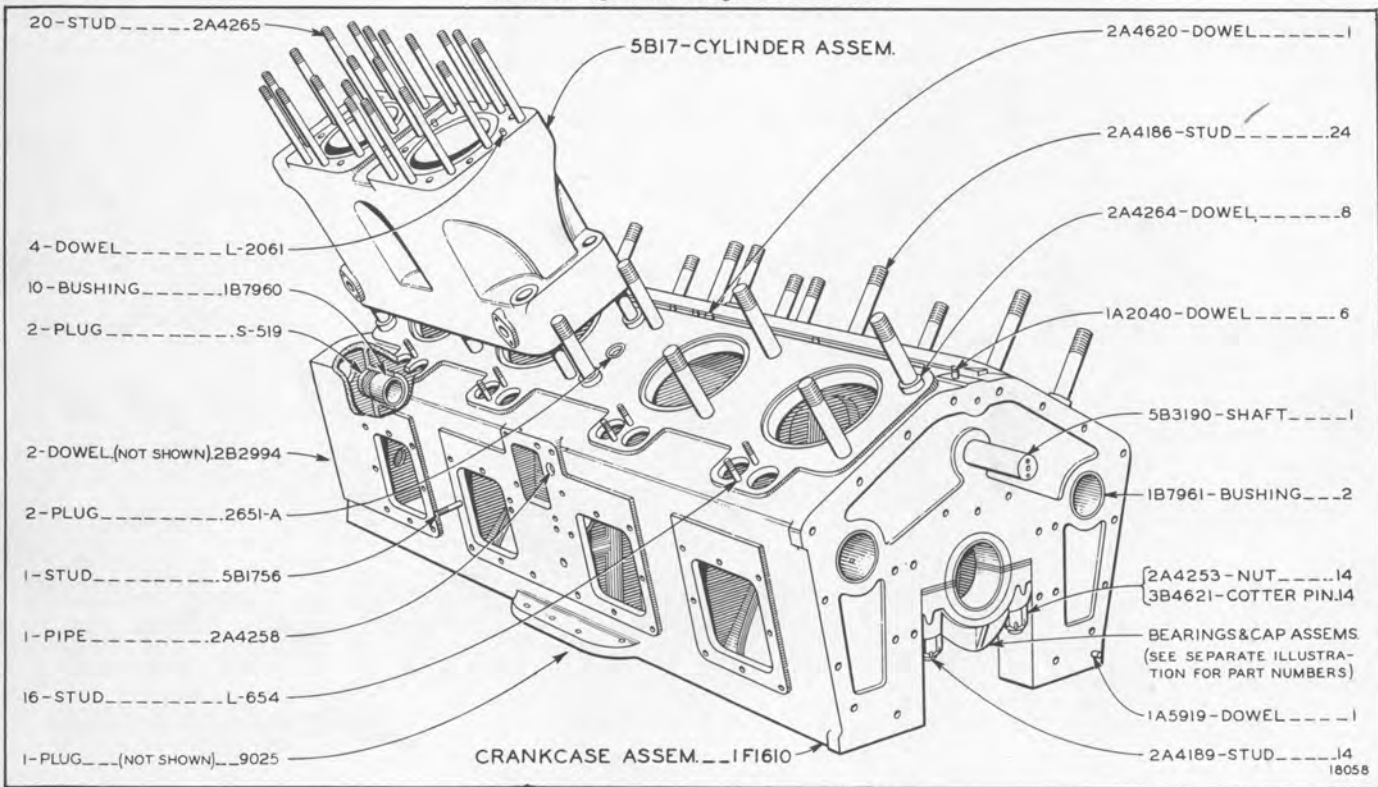

Crankcase and Cylinder Block Assemblies

Serial No. 9J5753SP to 9J6000SP and 3S1SP to 3S1856 Inclusive

CATERPILLAR D17000 DIESEL ENGINE

GEG-3861D

Always give engine serial number when ordering parts

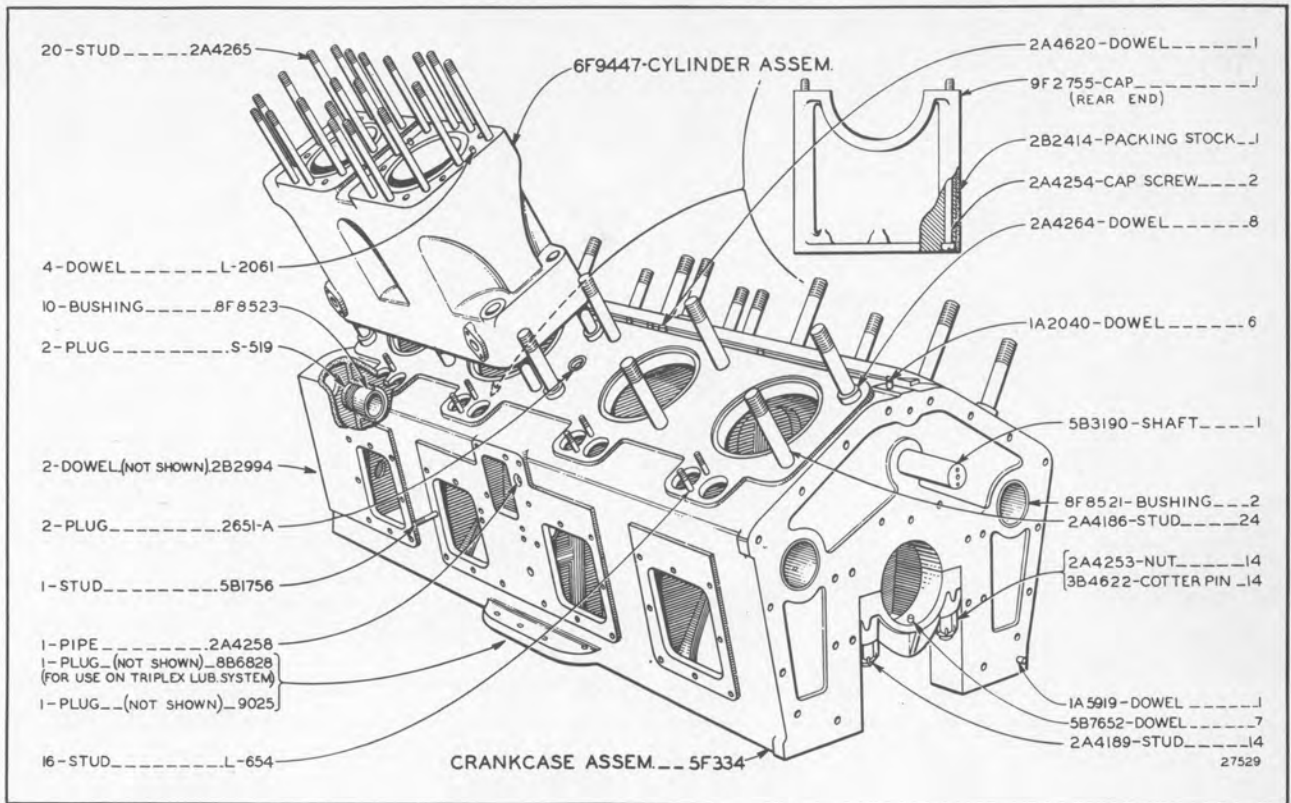

Crankcase and Cylinder Block Assemblies
Serial No. 3S1857 to 3S2000 Inclusive and 8S5001-Up

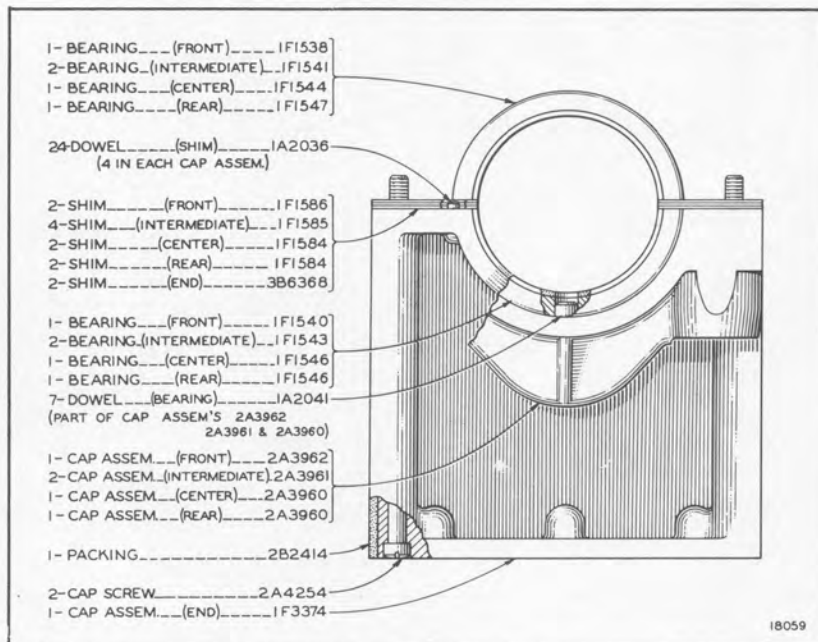

Crankshaft Bearings and Caps
Serial No. 9J5144SP to 9J6000SP and 3S1SP to 3S1856 Inclusive

CATERPILLAR D17000 DIESEL ENGINE

Always give engine serial number when ordering parts

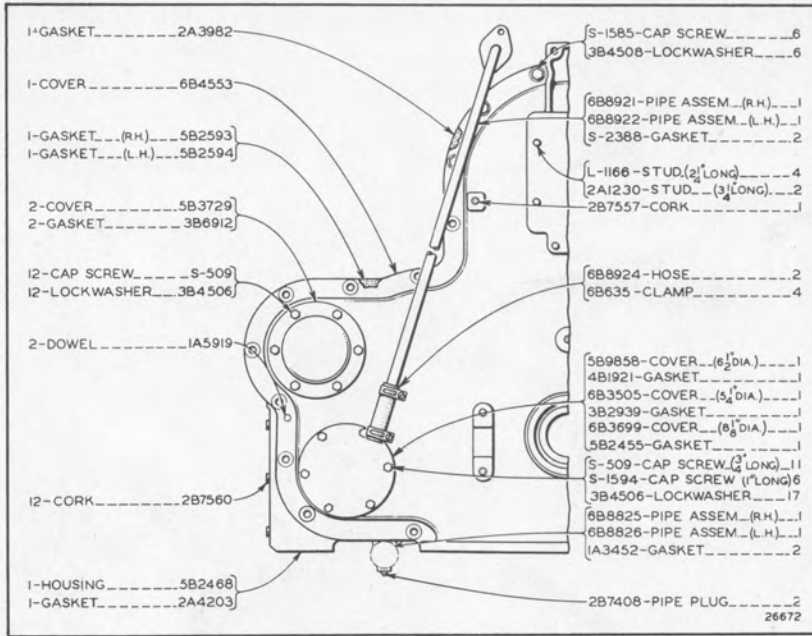

Timing Gear Housing
 Serial No. 9J5144SP to 9J5213SP Inclusive

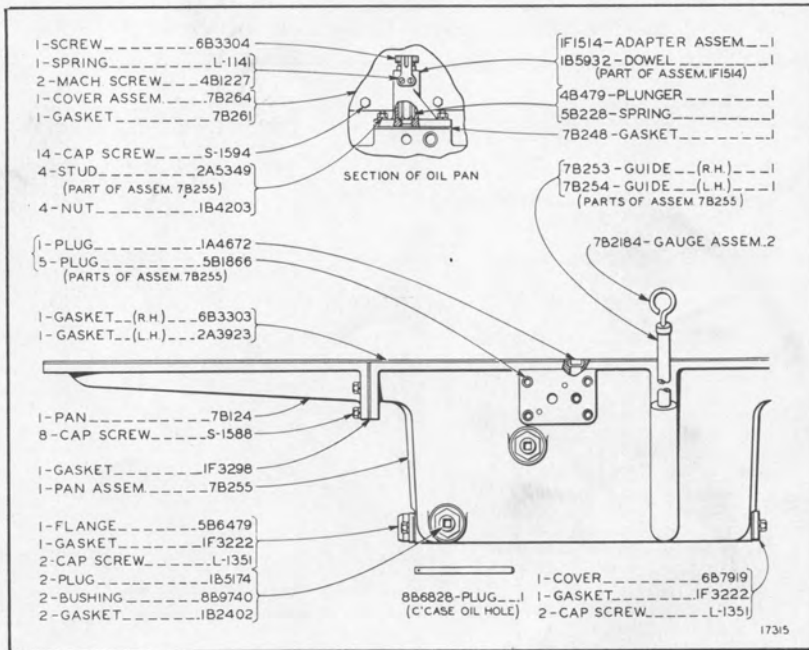

Oil Pan
 Serial No. 9J5144SP to 9J6000SP and 3S1SP to 3S116SP Inclusive

CATERPILLAR D17000 DIESEL ENGINE

GEG-3861D

Always give engine serial number when ordering parts

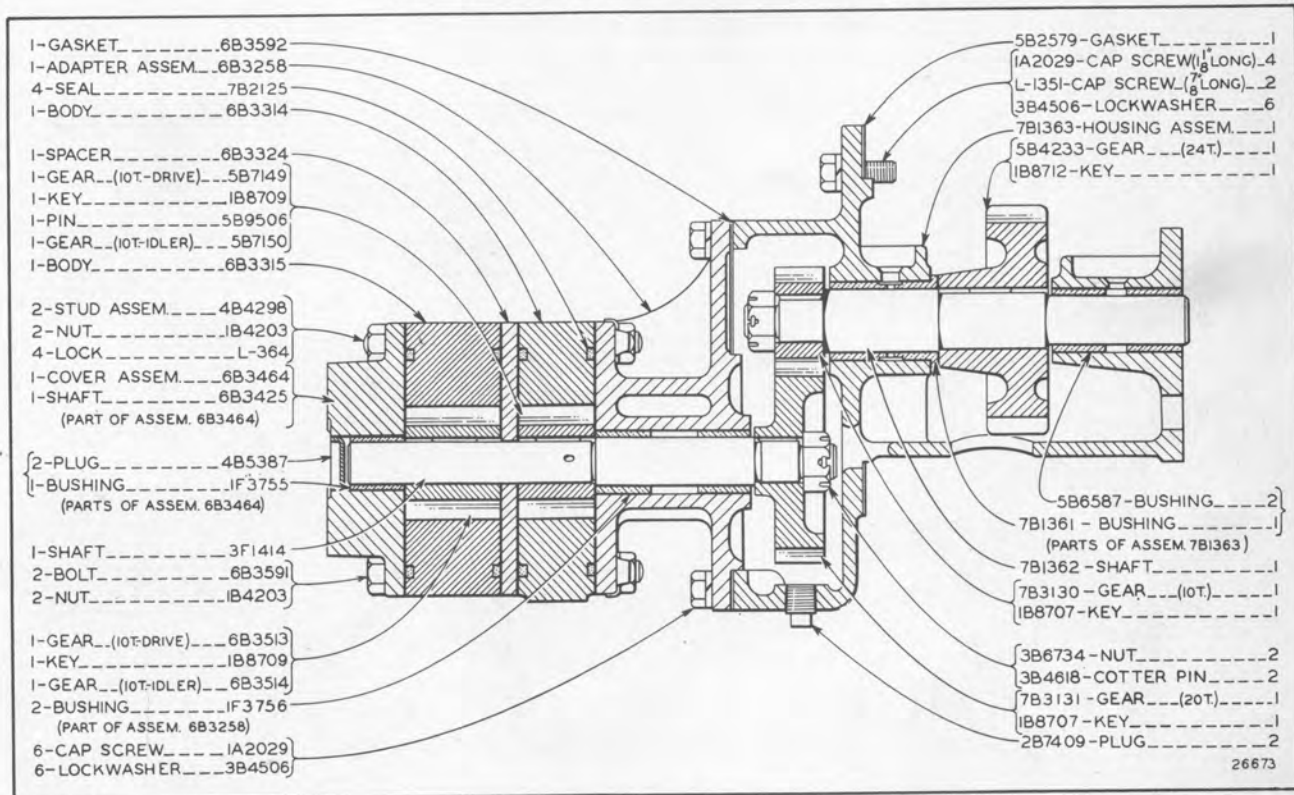
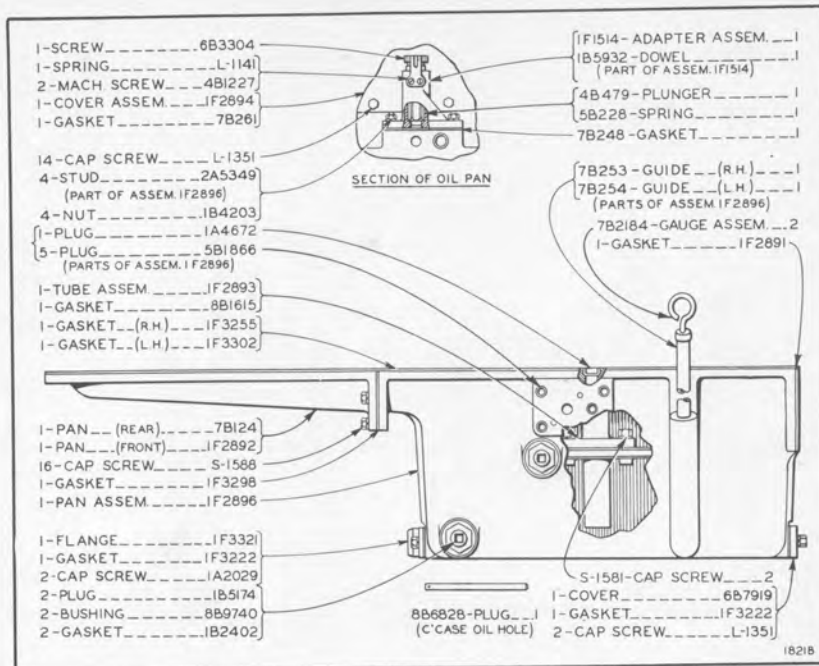

CATERPILLAR D17000 DIESEL ENGINE

Always give engine serial number when ordering parts

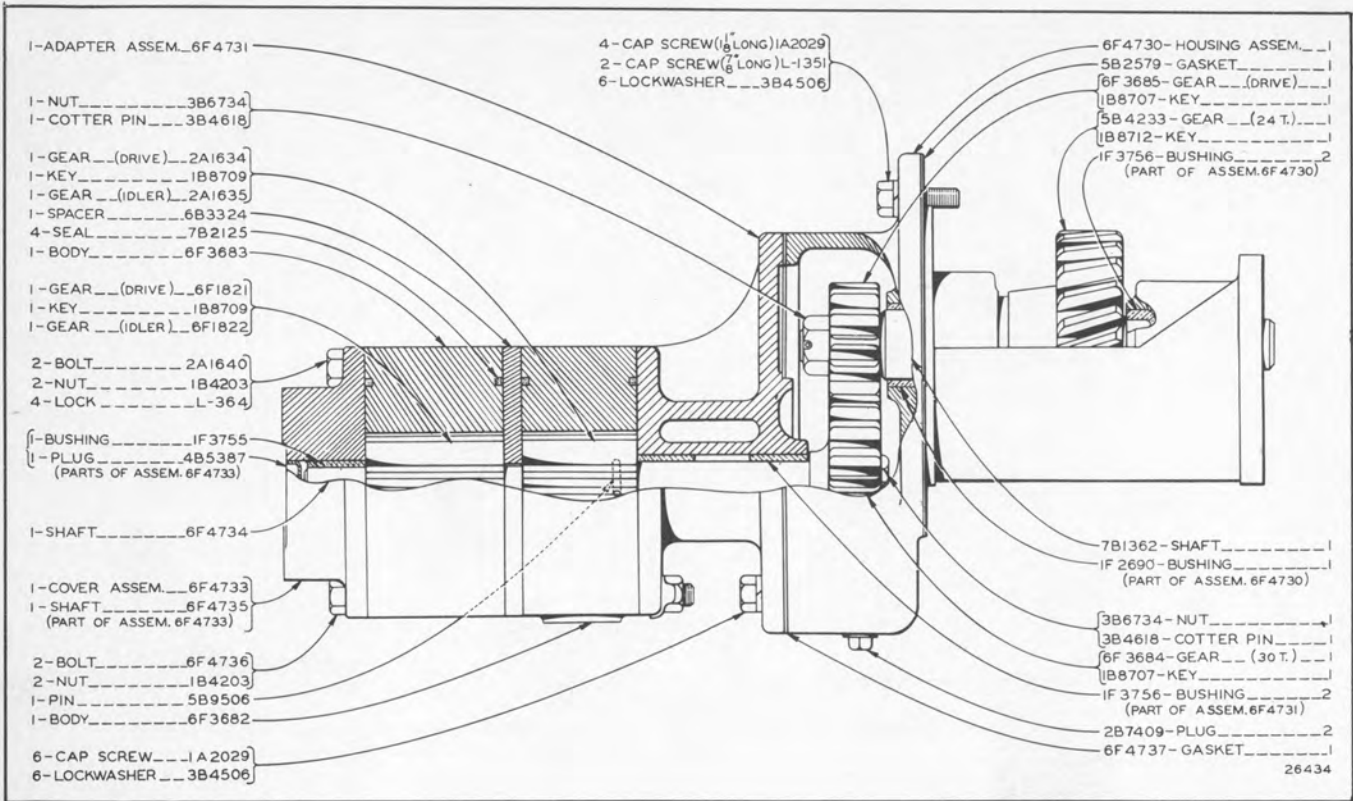

6F4729 Oil Pump Group
 Effective with Serial No. 8S6184

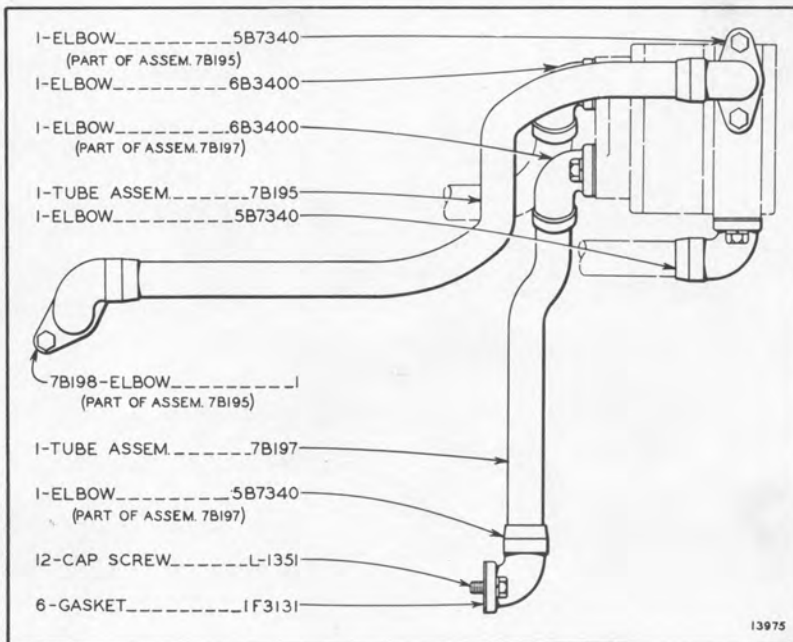

Oil Pump Lines
 Serial No. 9J5144SP to 9J6000SP and 3S1SP to 3S116SP Inclusive

CATERPILLAR D17000 DIESEL ENGINE

GEG-3861D

Always give engine serial number when ordering parts

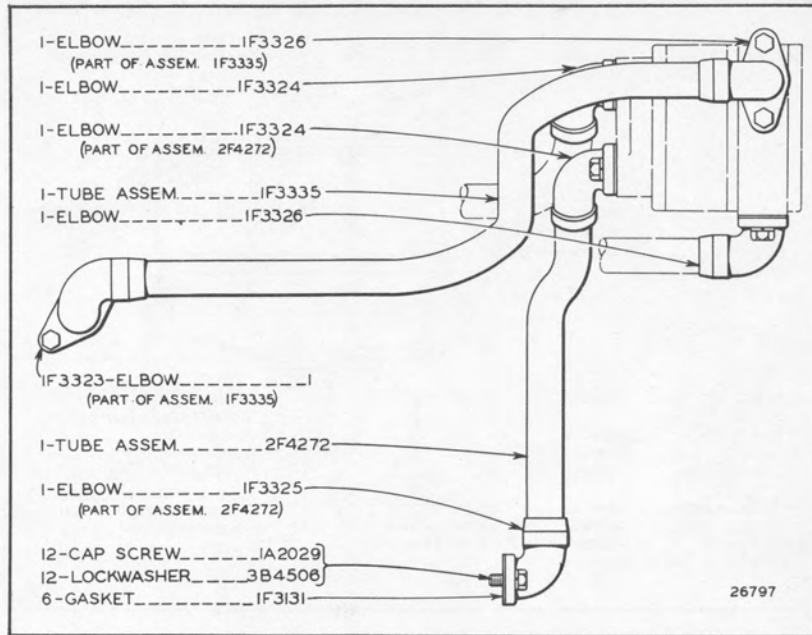

Oil Pump Lines

Serial No. 3S117SP to 3S2000 and 8S5001 to 8S6183 Inclusive

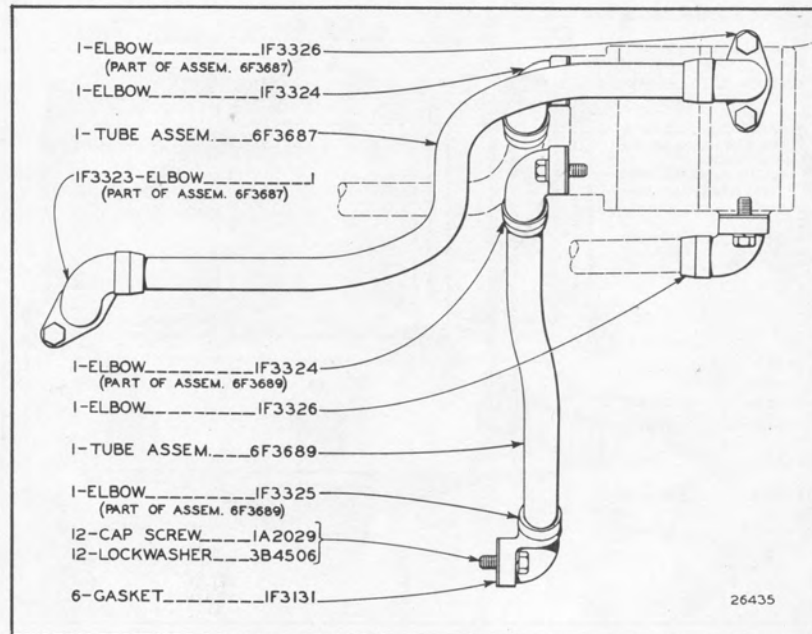

Oil Pump Lines

Effective with Serial No. 8S6184

CATERPILLAR D17000 DIESEL ENGINE

Always give engine serial number when ordering parts

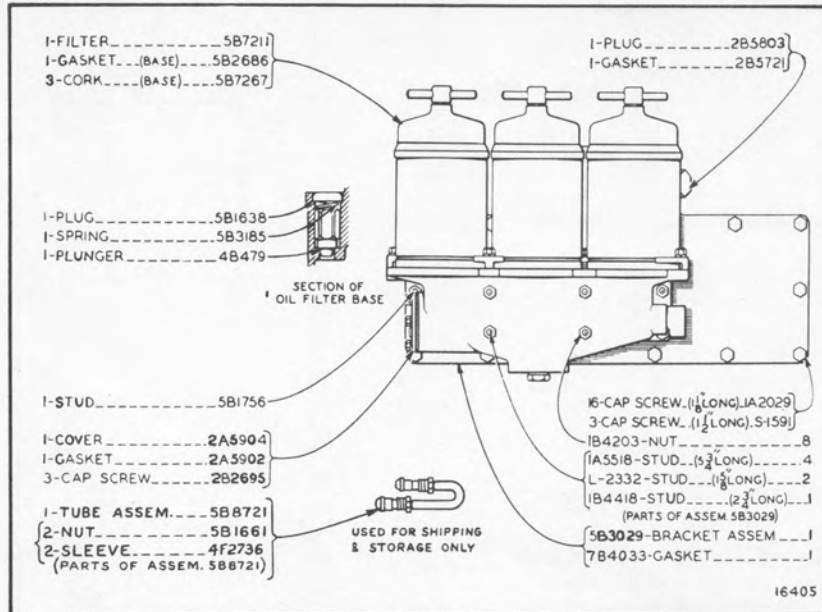

Oil Filter

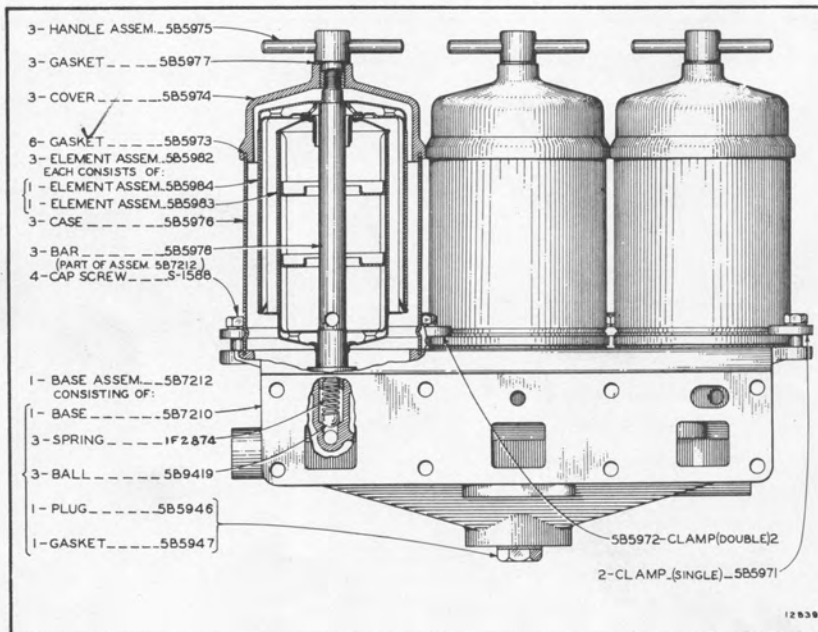

5B7211 Oil Filter

CATERPILLAR D17000 DIESEL ENGINE

GEG-3861D

Always give engine serial number when ordering parts

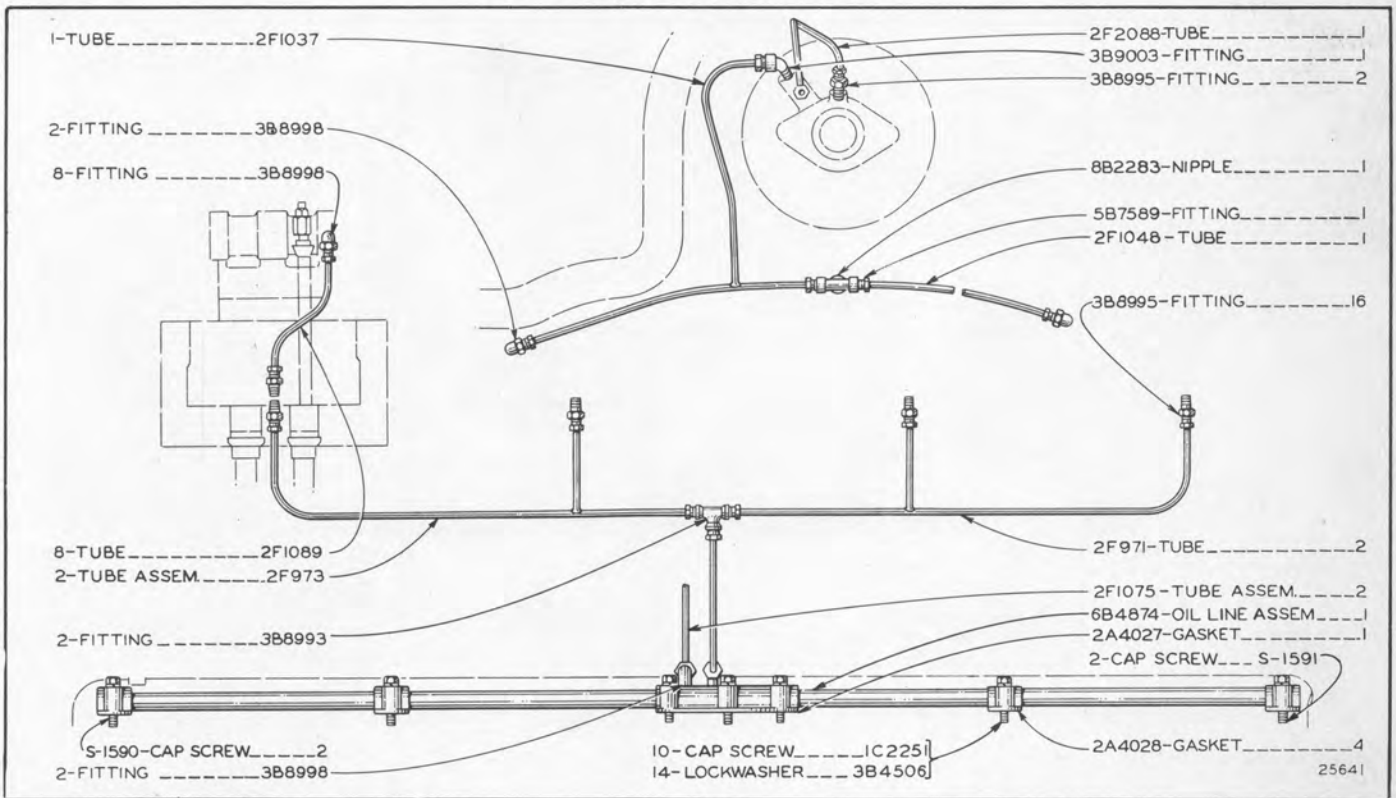
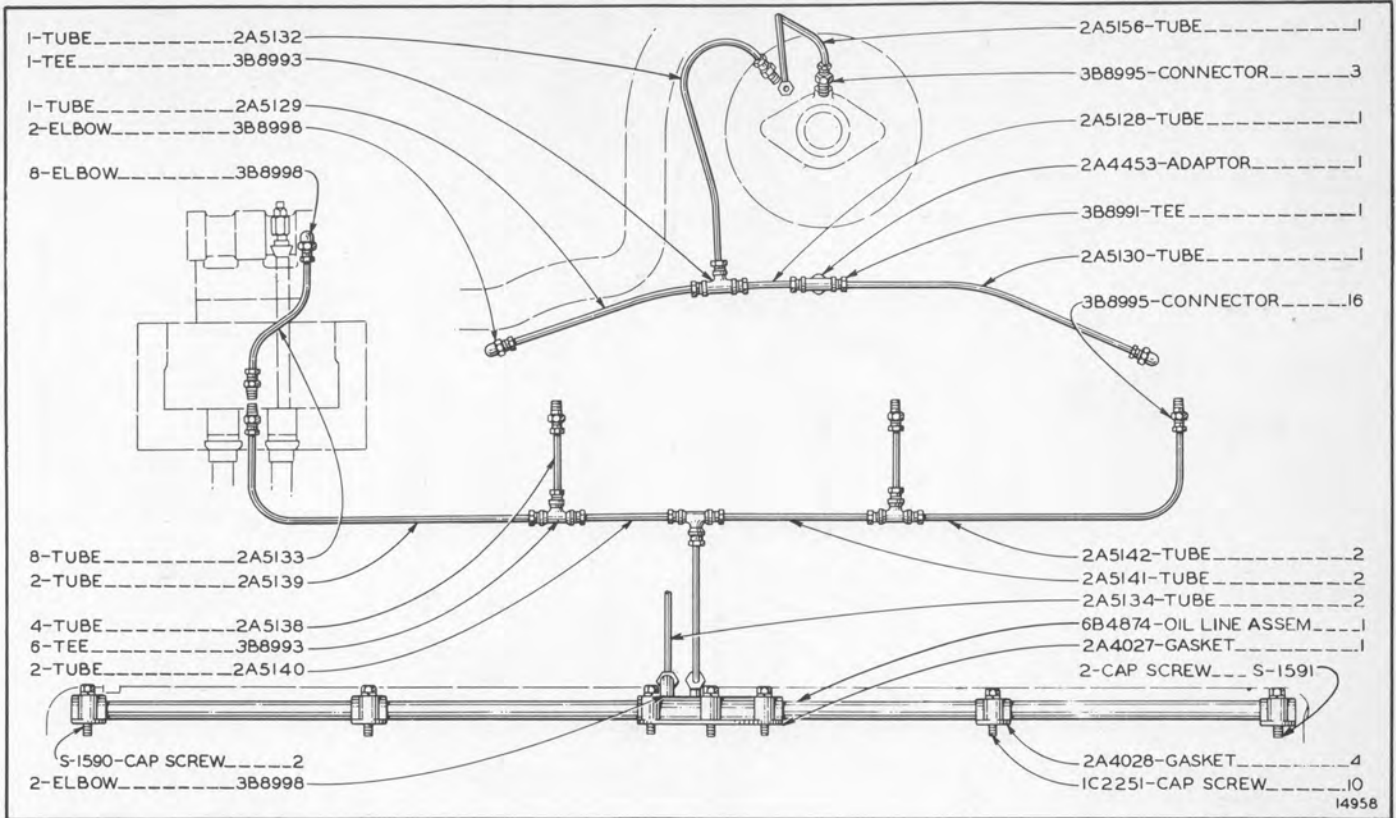

Serial No. 9J5420SP to 9J6000SP, 3S1SP to 3S2000 and 8S5001 to 8S6183 Inclusive

CATERPILLAR D17000 DIESEL ENGINE

Always give engine serial number when ordering parts

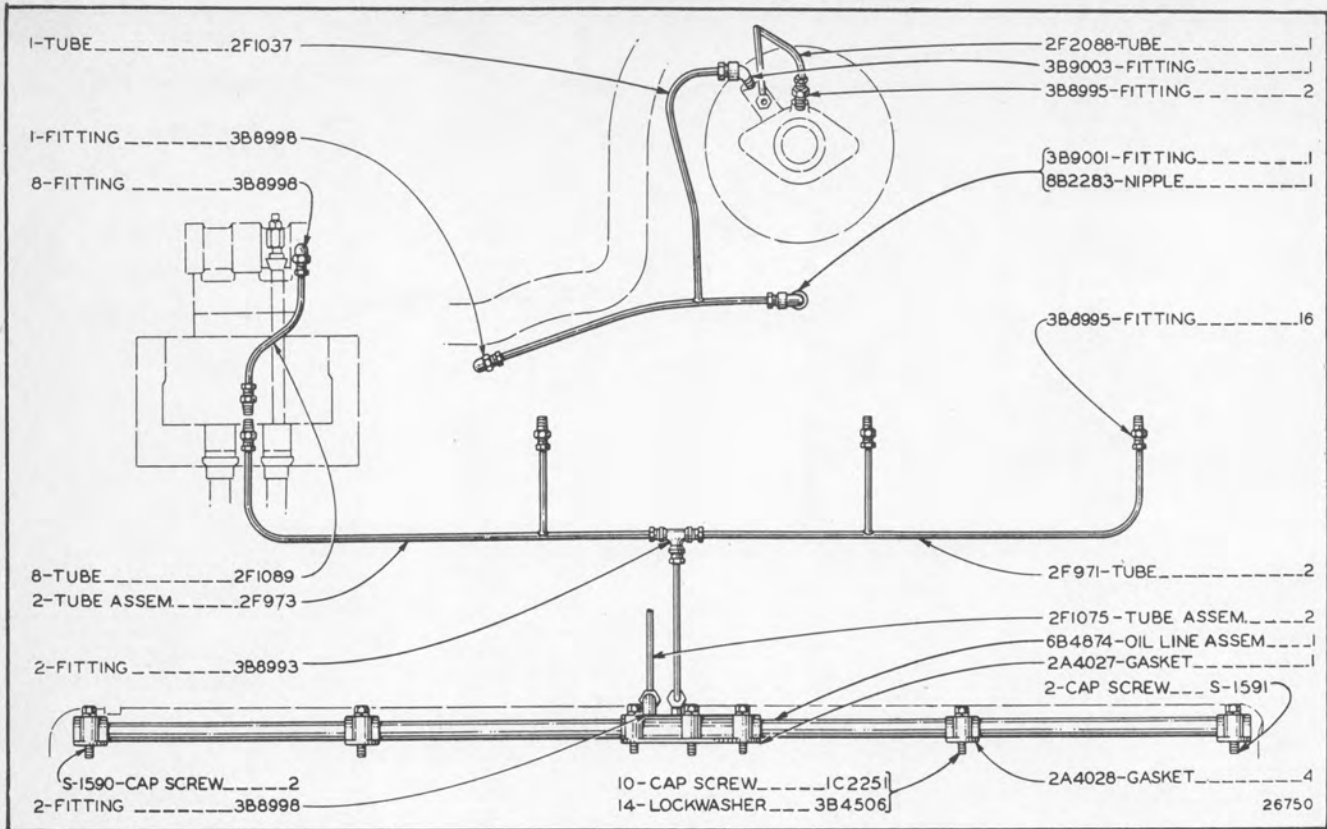

Oil Lines

Effective with Serial No. 8S6184

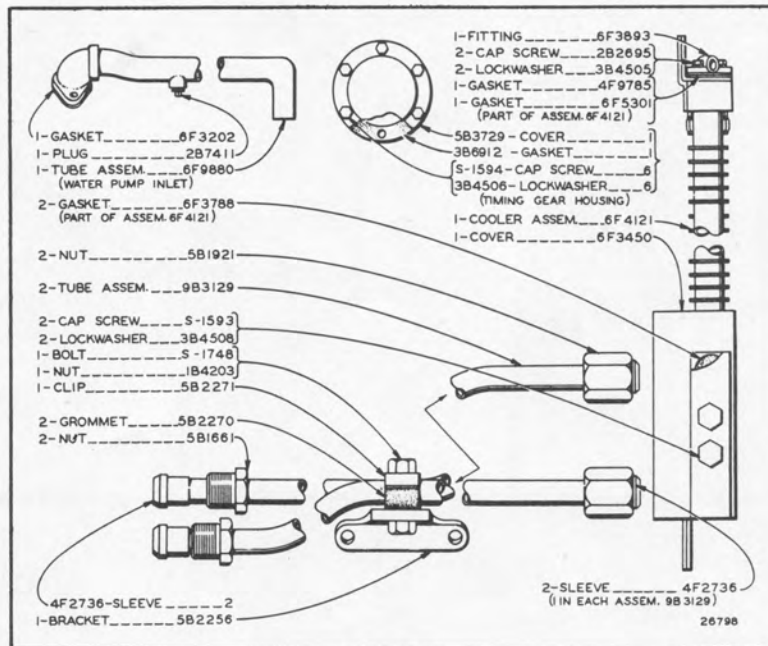

Oil Cooler

Effective with Serial No. 8S6184

Always give engine serial number when ordering parts

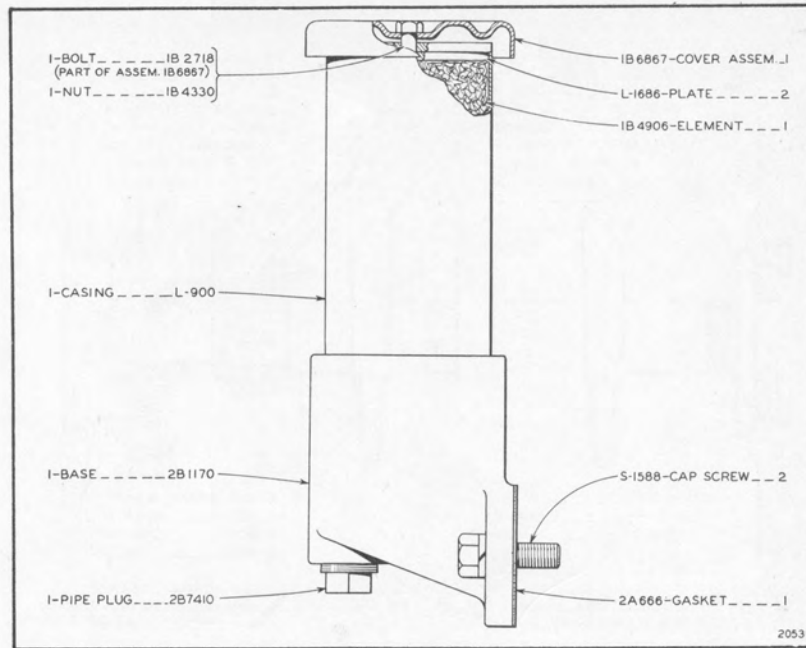

Breather

Serial No. 9J5144SP to 9J5267SP Inclusive

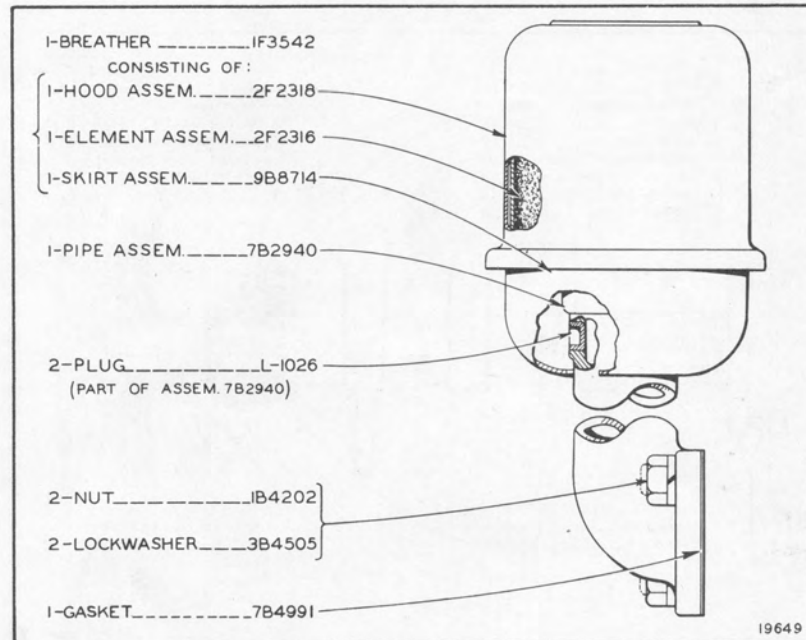

Breather

Serial No. 9J5268SP to 9J6000SP, 3S1SP to 3S2000 Inclusive and 8S5001-Up

CATERPILLAR D17000 DIESEL ENGINE

Always give engine serial number when ordering parts

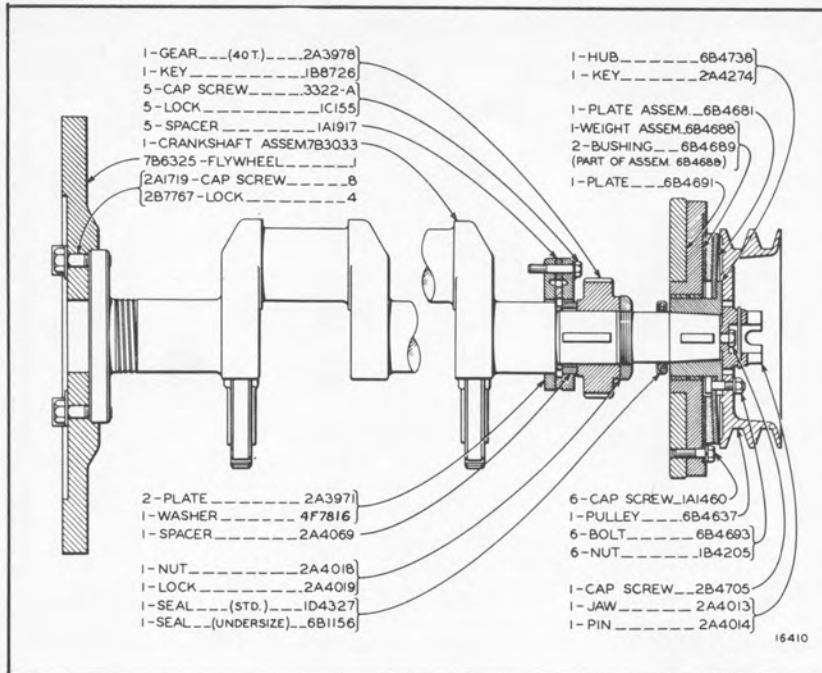

Crankshaft

Serial No. 9J5667SP to 9J6000SP and 3S1SP to 3S1856 Inclusive

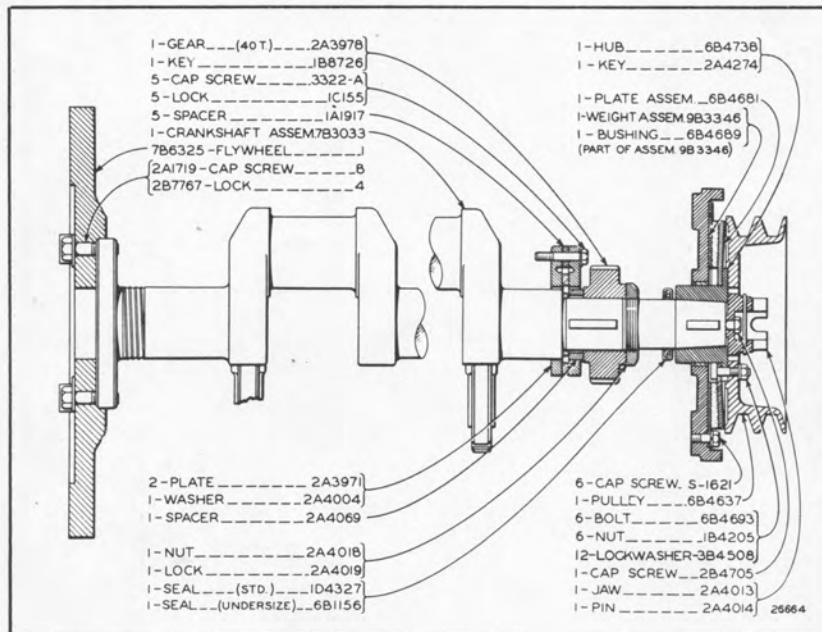

Crankshaft

Serial No. 9J5144SP to 9J5666SP Inclusive

CATERPILLAR D17000 DIESEL ENGINE

GEG-3861D

Always give engine serial number when ordering parts

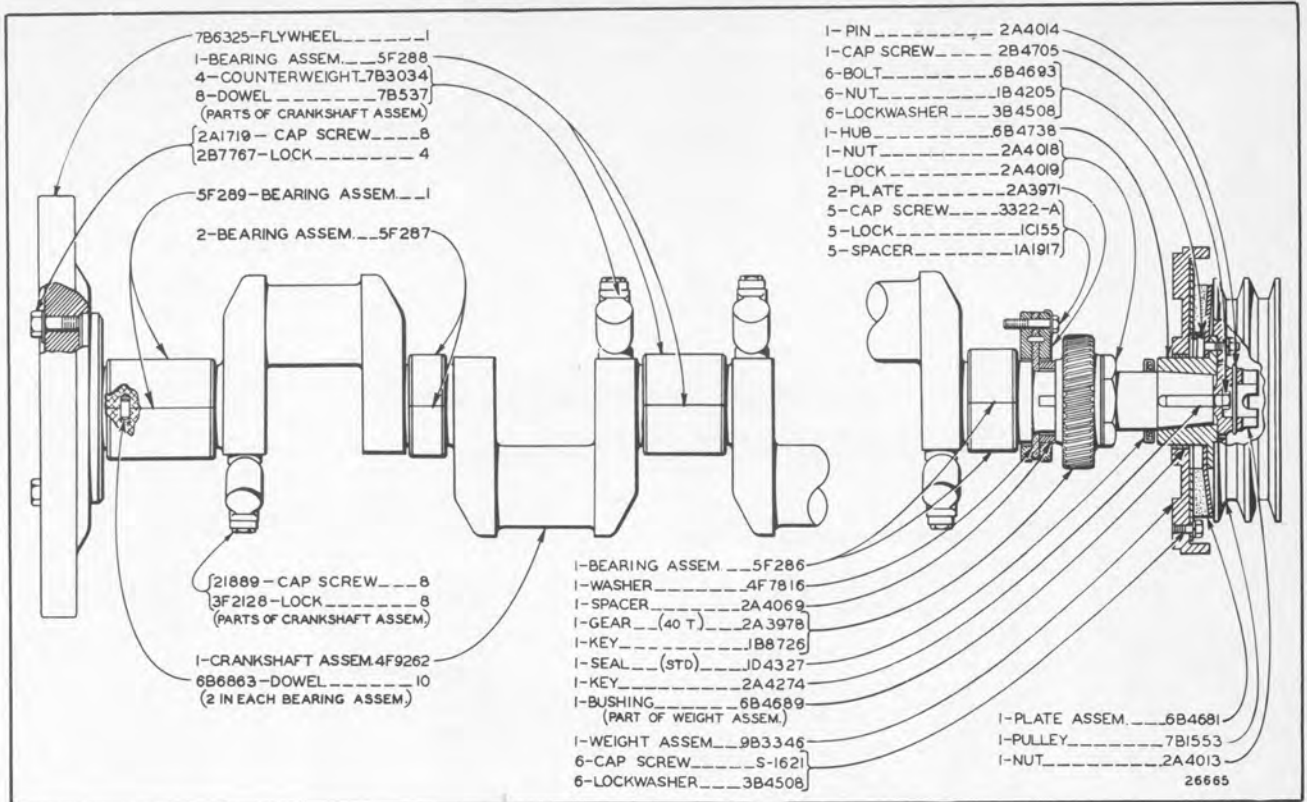

Crankshaft

Serial No. 3S1857 to 3S2000 and 8S5001 to 8S6183 Inclusive

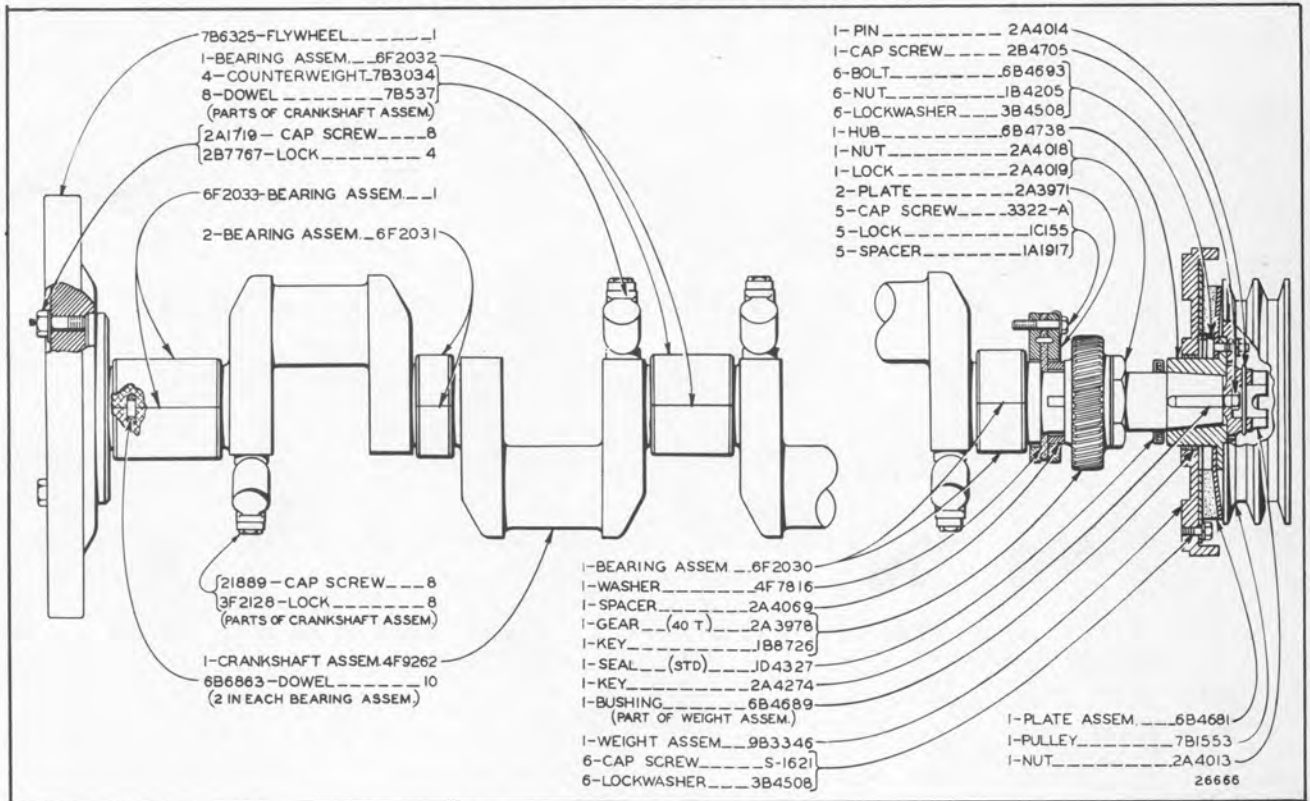

Crankshaft

Effective with Serial No. 8S6184

CATERPILLAR D17000 DIESEL ENGINE

Always give engine serial number when ordering parts

CRANKSHAFT BEARINGS AND CAPS

*Crankshaft bearing replacement group—line reamed
Serial No. 9J5144SP to 9J6000SP and 3S1SP to 3S1856 inclusive
Only separate parts serviced.*

When complete group is required, order	Standard	0.050 in. undersize
	5F368	5F367
1—BEARING—Front Upper	1F1538	1F2015
1—BEARING—Front Lower	1F1540	1F2044
2—SHIM—Front Bearing	1F1586	1F1741
2—BEARING—Intermediate Upper	1F1541	1F2017
2—BEARING—Intermediate Lower	1F1543	1F2048
4—SHIM—Intermediate Bearing	1F1585	1F1742
1—BEARING—Center Upper	1F1544	1F2020
1—BEARING—Center Lower	1F1546	1F2047
2—SHIM—Center Bearing	1F1584	1F1740
1—BEARING—Rear Upper	1F1547	1F2021
1—BEARING—Rear Lower	1F1546	1F2047
2—SHIM—Rear Bearing	1F1584	1F1740
1—CAP ASSEMBLY—Rear End	2A3977	1F2160
2—SHIM—End Cap Assembly	3B6368	3B9259
1 oz.—PACKING—End Cap Assembly	2B2414	2B2414

CATERPILLAR D17000 DIESEL ENGINE

GEG-3861D

Always give engine serial number when ordering parts

*Crankshaft bearing replacement group
Serial No. 3S1857 to 3S2000, and 8S5001 to 8S6183 inclusive.*

	Standard	0.050 in. Undersize
Complete Group	5F444	5F443
Consists of:		
1 Bearing assembly—front	5F286	5F362
2 Bearing assembly—intermediate	5F287	5F361
1 Bearing assembly—center	5F288	5F360
1 Bearing assembly—rear	5F289	5F363

*Crankshaft bearing replacement group
Serial 8S6184 and up*

	Standard	0.050 in. Undersize
Complete Group	6F2038	6F2039
Consists of:		
1 Bearing assembly—front	6F2030	6F2034
2 Bearing assembly—intermediate	6F2031	6F2035
1 Bearing assembly—center	6F2032	6F2036
1 Bearing assembly—rear	6F2033	6F2037

CATERPILLAR D17000 DIESEL ENGINE

Always give engine serial number when ordering parts

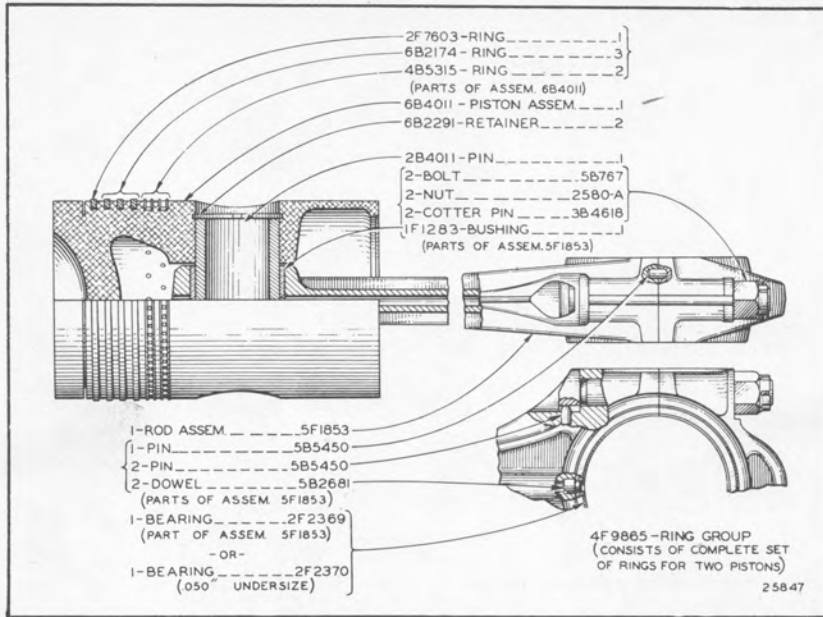

Connecting Rod and Piston (8 Groups Req'd)

Serial No. 9J5144SP to 9J6000SP, 3S1SP to 3S2000 and 8S5001 to 8S6183 Inclusive

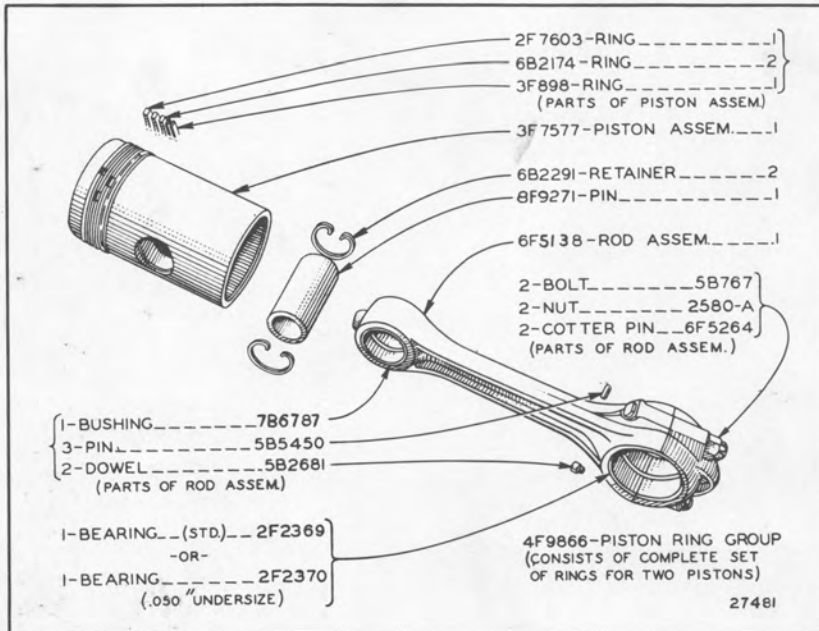

Connecting Rod and Piston (8 Groups Req'd)

Effective with Serial No. 8S6184

CATERPILLAR D17000 DIESEL ENGINE

GEG-3861D

Always give engine serial number when ordering parts

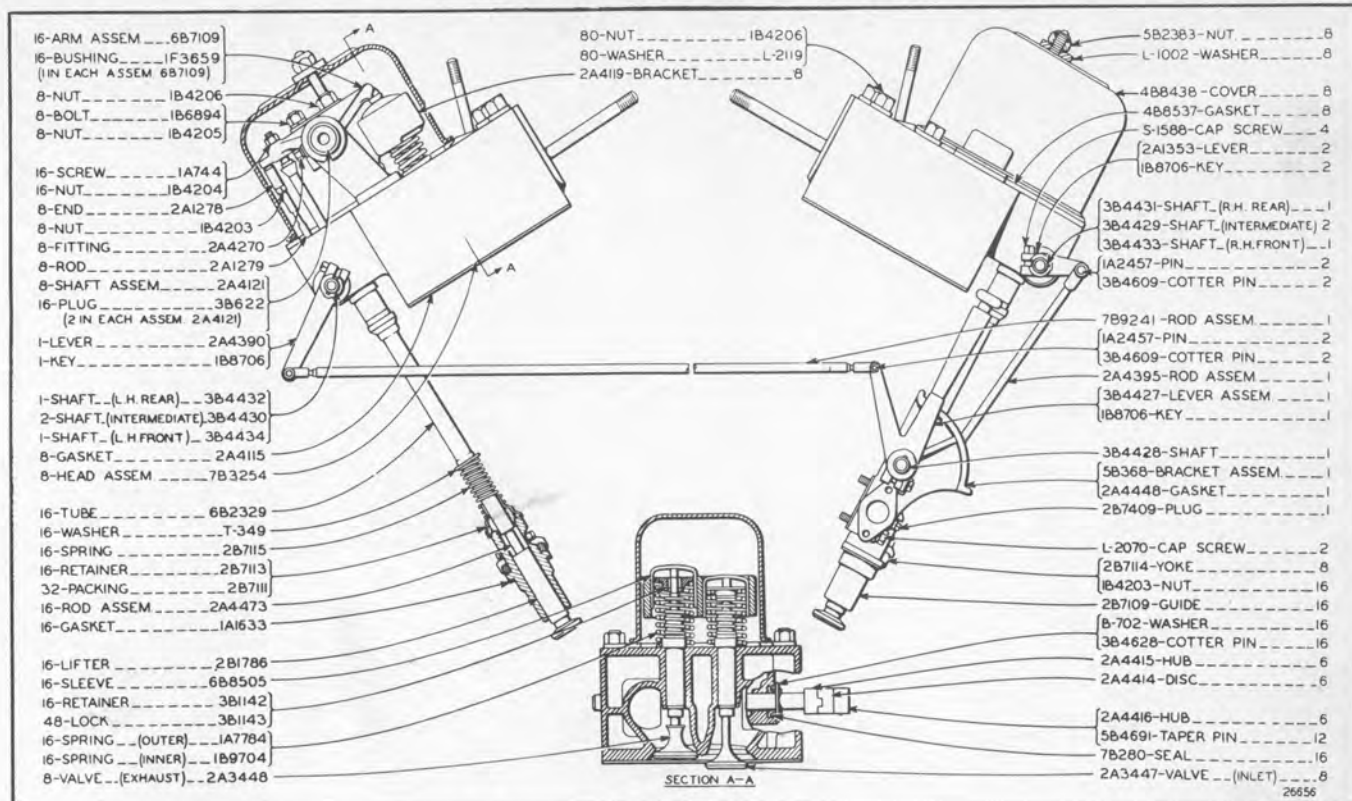

Cylinder Head and Valve Mechanism
 Serial No. 9J5144SP to 9J5569SP Inclusive

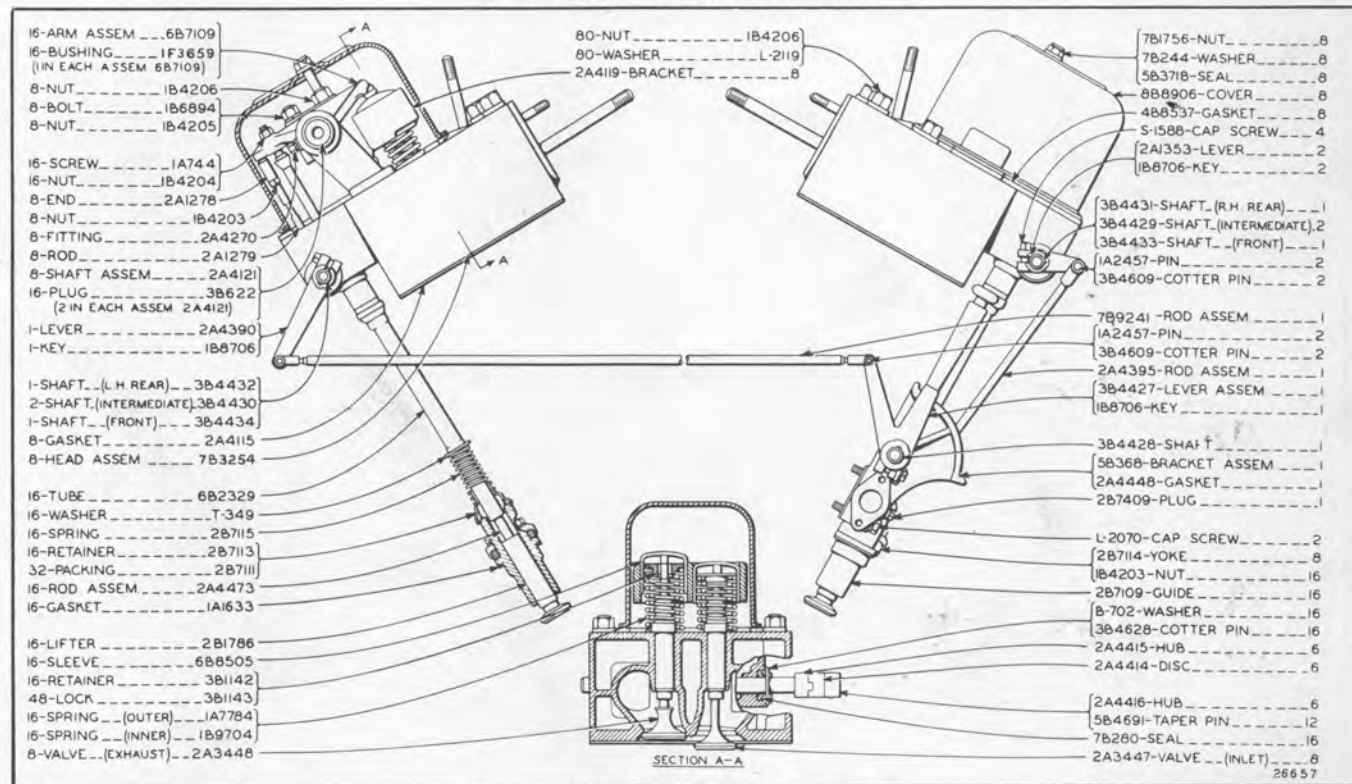

Cylinder Head and Valve Mechanism
 Serial No. 9J5570SP to 9J5715SP Inclusive

CATERPILLAR D17000 DIESEL ENGINE

Always give engine serial number when ordering parts

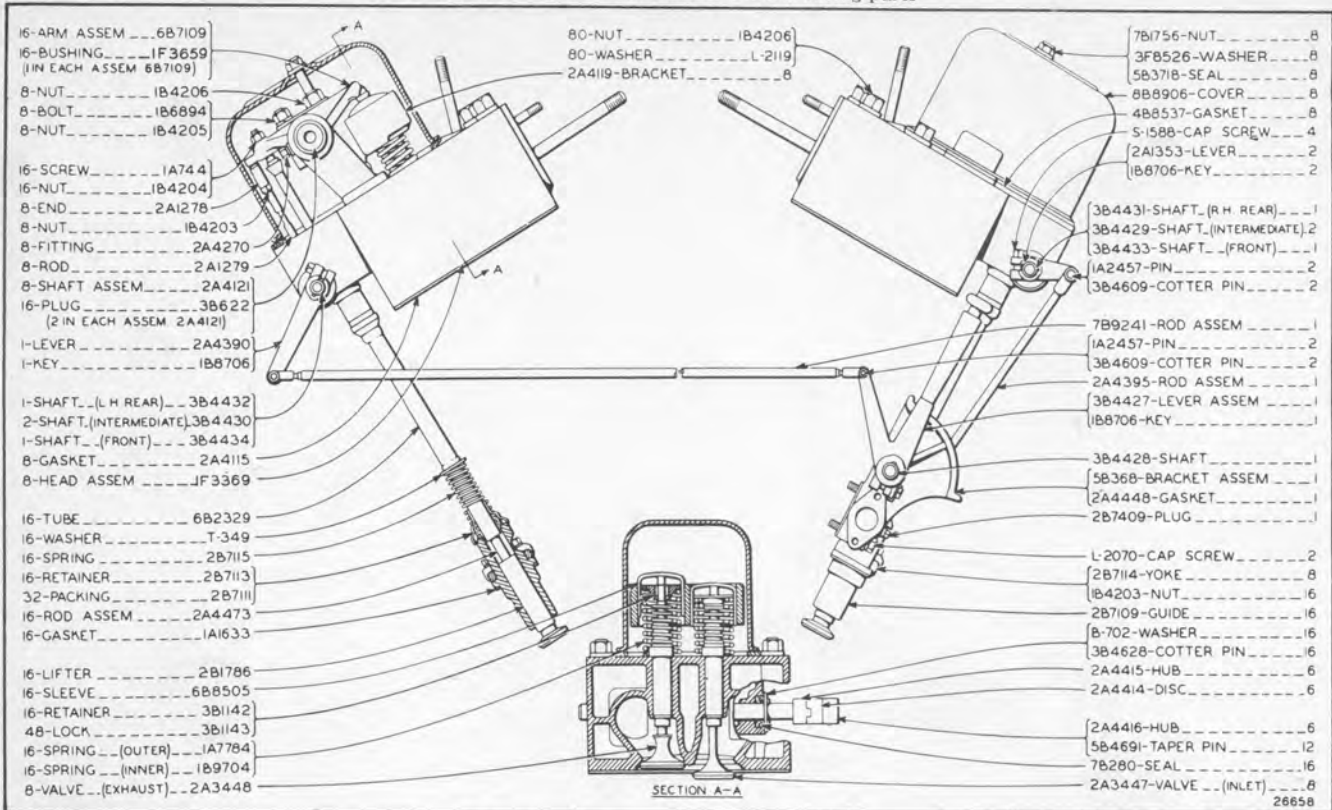

Cylinder Head and Valve Mechanism

Serial No. 9J5716SP to 9J6000SP, 3S1SP to 3S2000 and 8S5001 to 8S6183 Inclusive

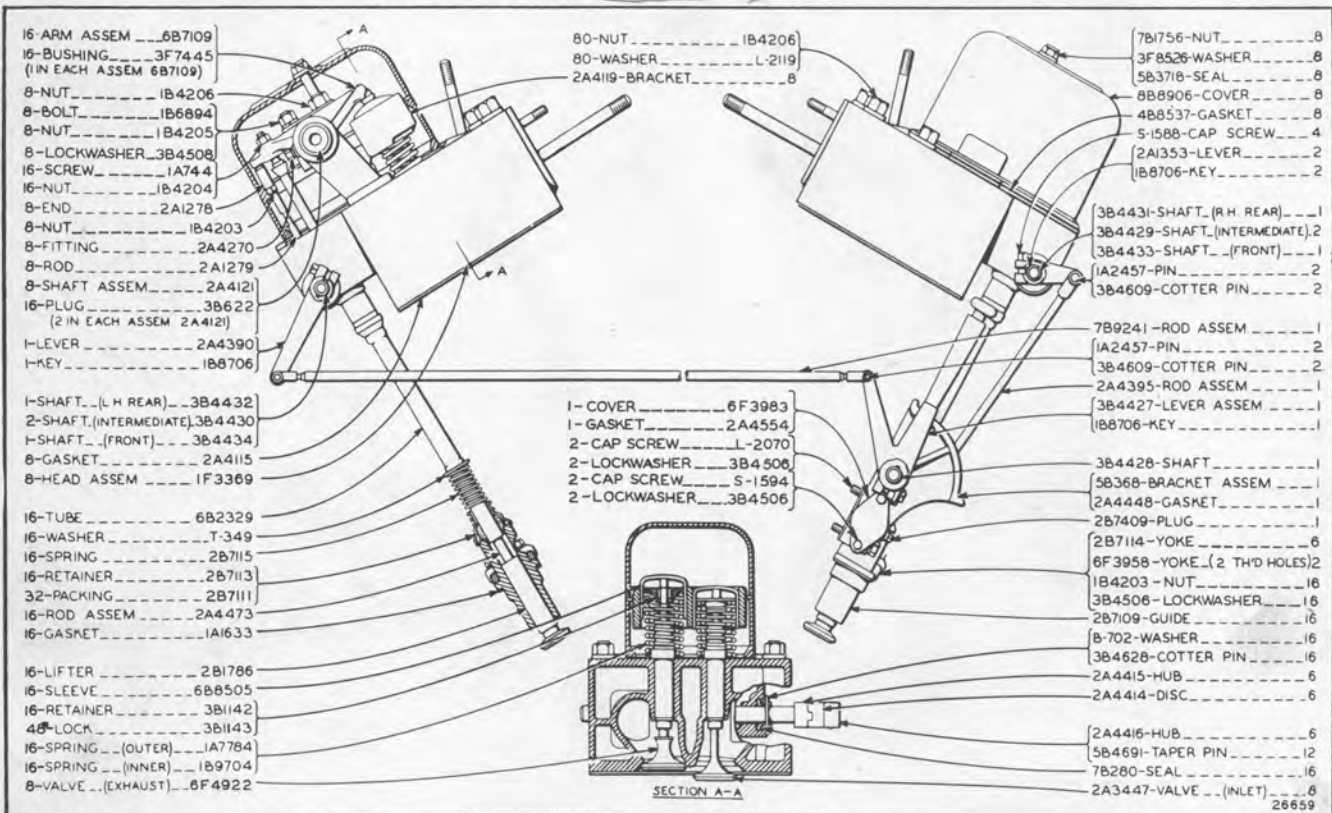

Cylinder Head and Valve Mechanism

Serial No. 8S6184 to 8S6422 Inclusive

CATERPILLAR D17000 DIESEL ENGINE

GEG-3861D

Always give engine serial number when ordering parts

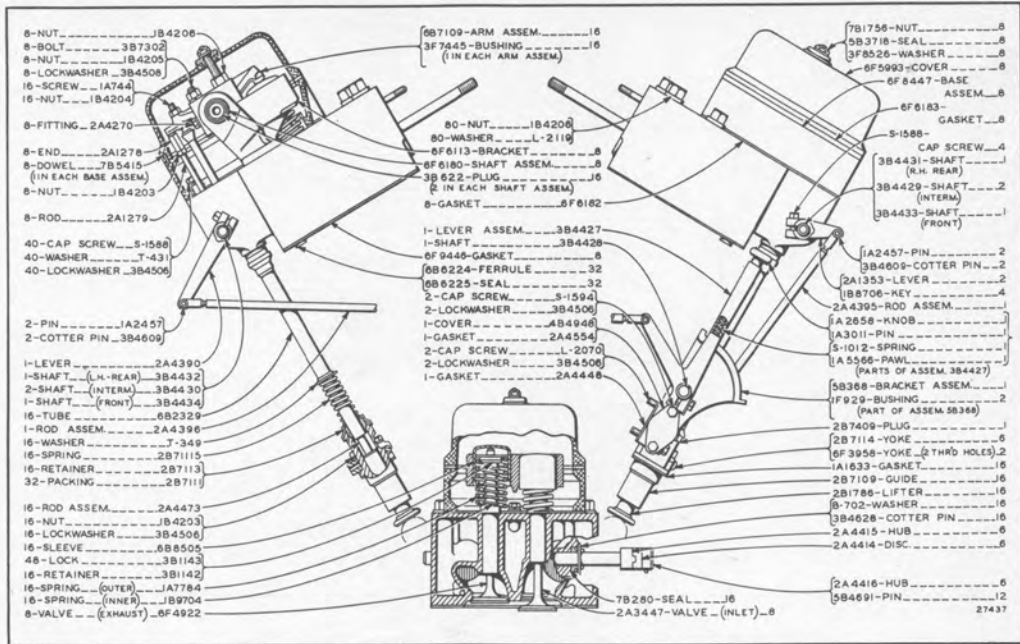

Cylinder Head and Valve Mechanism
Effective with Serial No. 8S6423

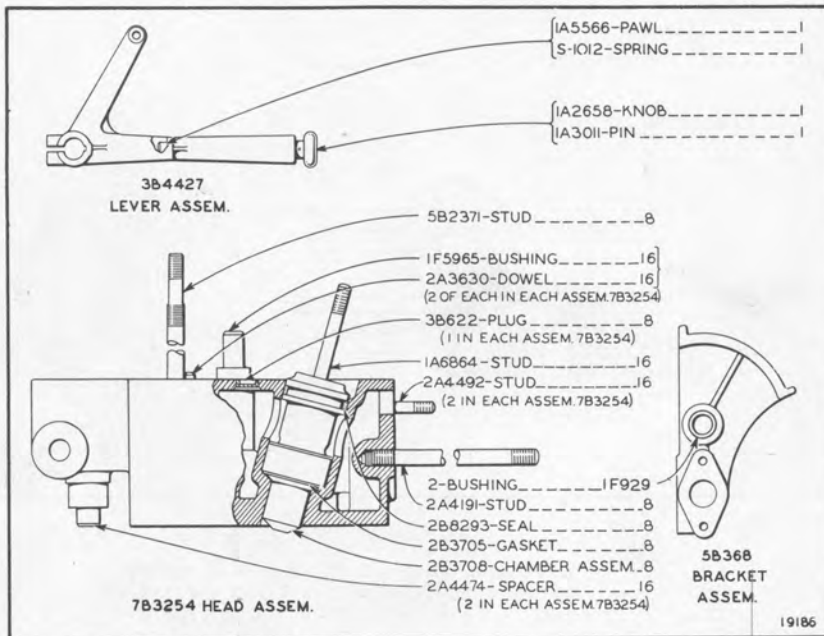

Cylinder Head and Valve Mechanism Assemblies
Serial No. 9J5144SP to 9J5569SP Inclusive

CATERPILLAR D17000 DIESEL ENGINE

Always give engine serial number when ordering parts

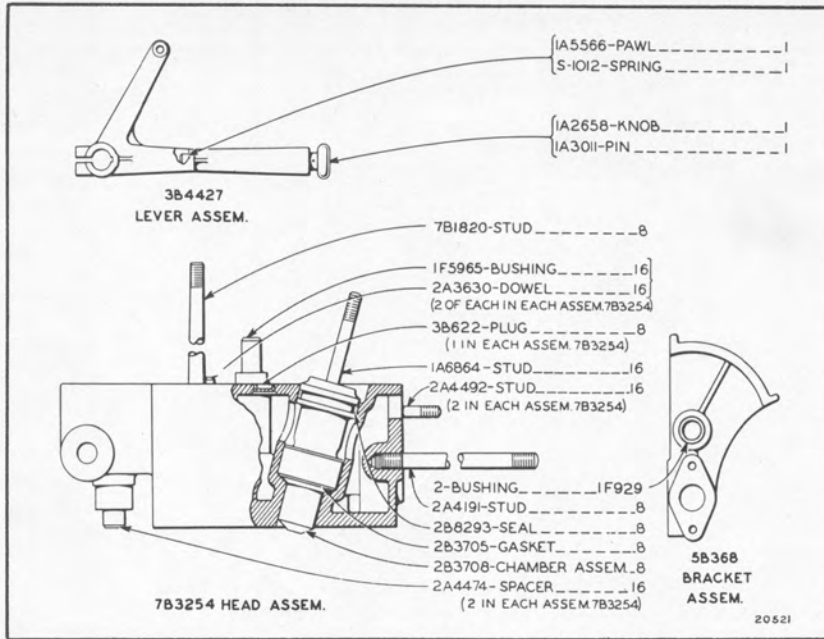

Cylinder Head and Valve Mechanism Assemblies
Serial No. 9J5570SP to 9J5715SP Inclusive

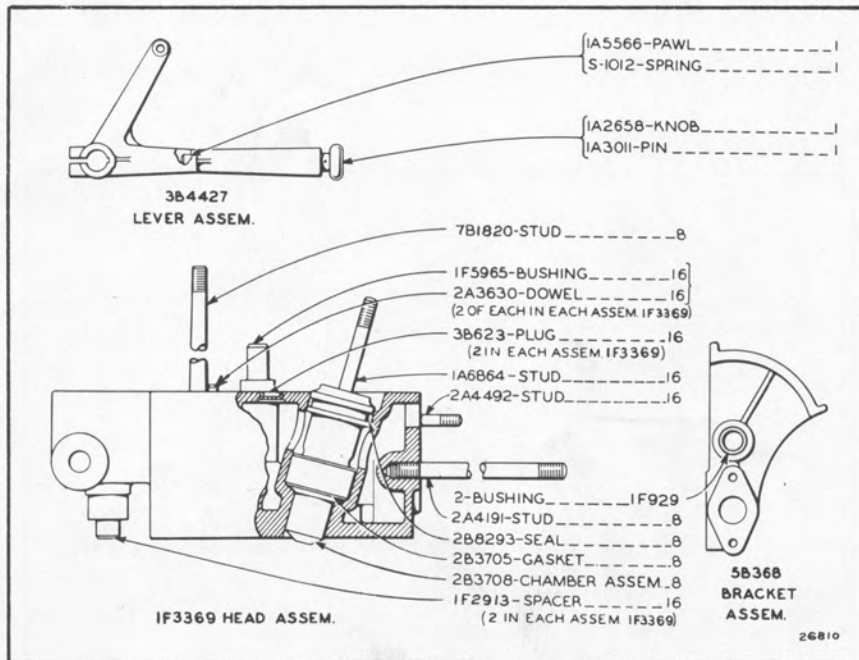

Cylinder Head and Valve Mechanism Assemblies
Serial No. 9J5716SP to 9J6000SP, 3S1SP to 3S2000 and 8S5001 to 8S6422 Inclusive

CATERPILLAR D17000 DIESEL ENGINE

GEG-3861D

Always give engine serial number when ordering parts

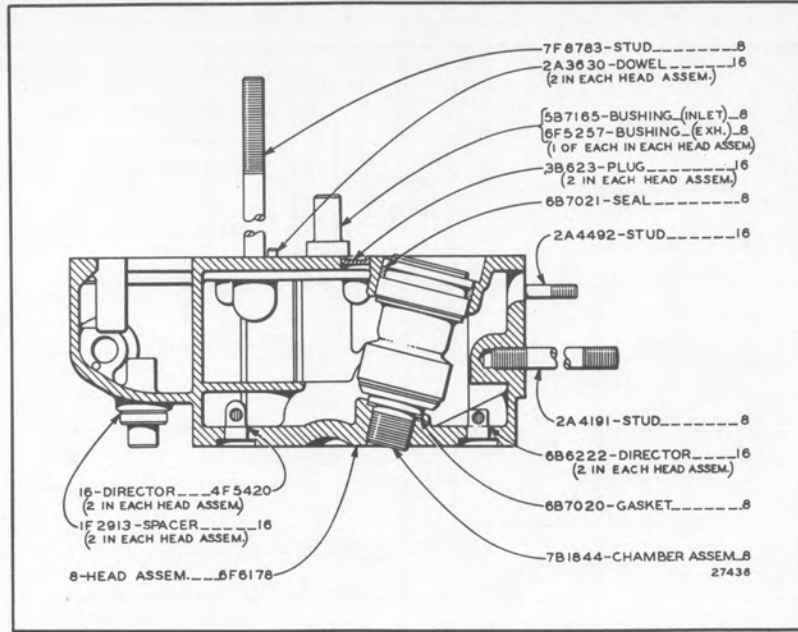

Cylinder Head Assemblies
 Effective with Serial No. 8S6423

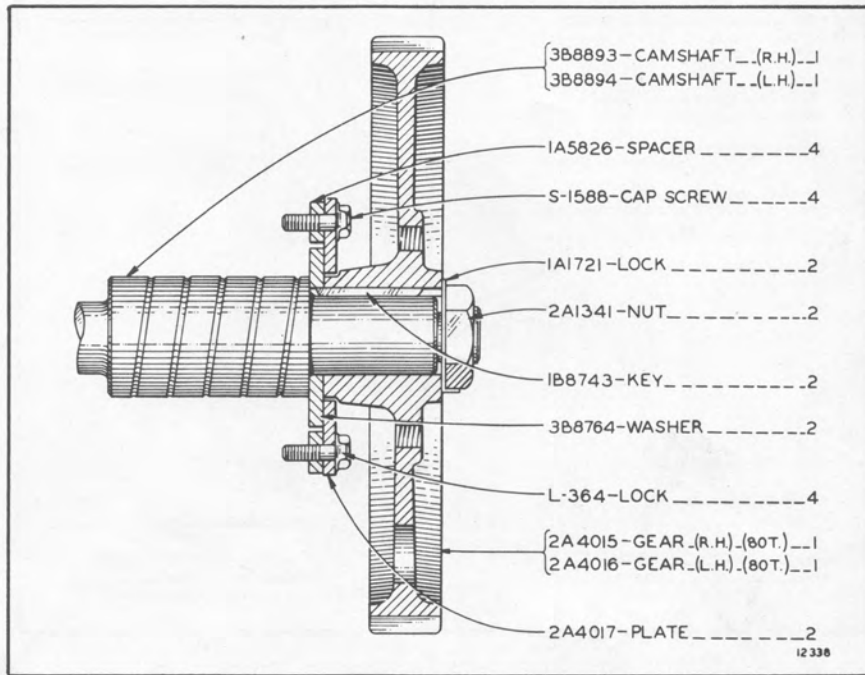

Camshaft

CATERPILLAR D17000 DIESEL ENGINE

Always give engine serial number when ordering parts

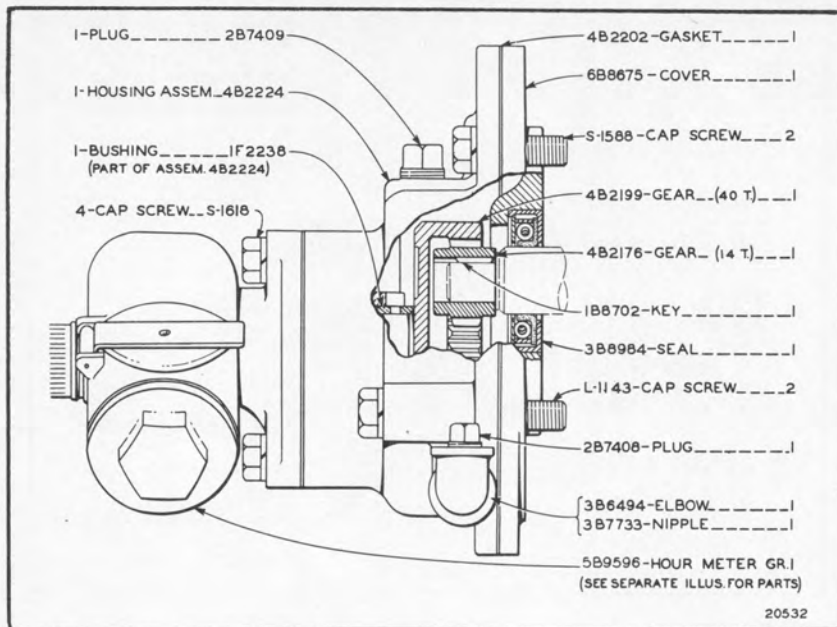

Hour Meter and Tachometer Drive

Serial No. 9J5144SP to 9J5795SP, 9J5842SP to 9J6000SP and 3S1SP to 3S8SP Inclusive

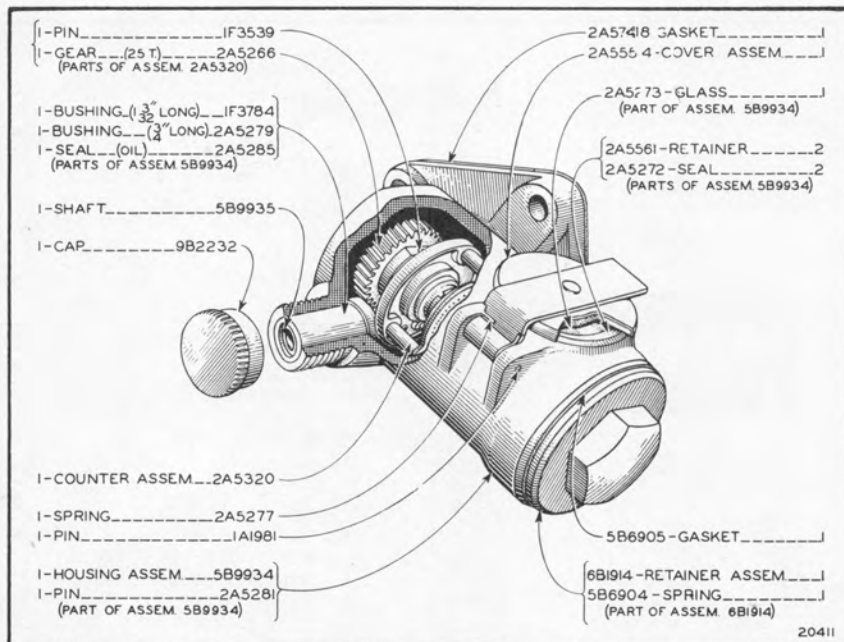

5B9596 Hour Meter and Tachometer Drive Group

Only Separate Parts Serviced. When Complete Group Is Required Order 9B2321.
Serial No. 9J5144SP to 9J5795SP, 9J5842SP to 9J6000SP and 3S1SP to 3S8SP Inclusive

CATERPILLAR D17000 DIESEL ENGINE

GEG-3861D

Always give engine serial number when ordering parts

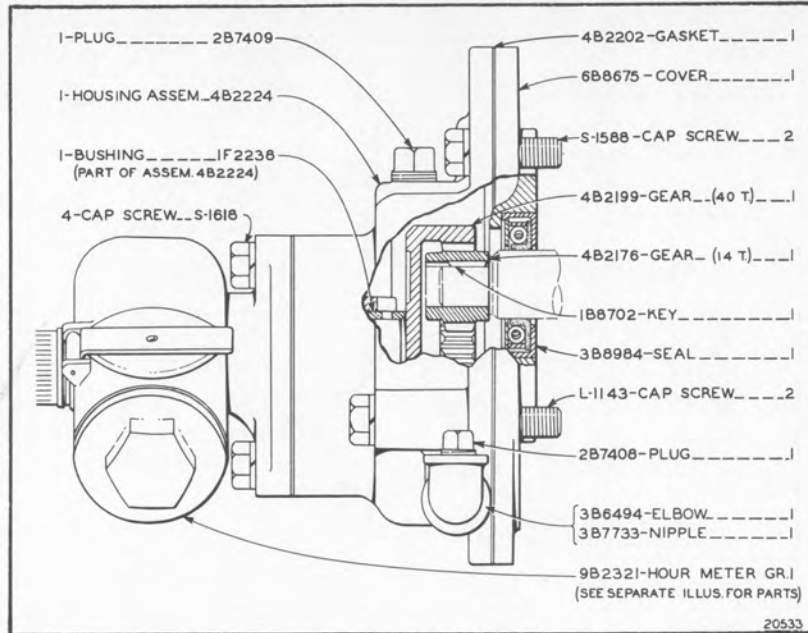

Hour Meter and Tachometer Drive

Serial No. 9J5796SP to 9J5841SP, 3S9SP to 3S2000 and 8S5001 to 8S6183 Inclusive

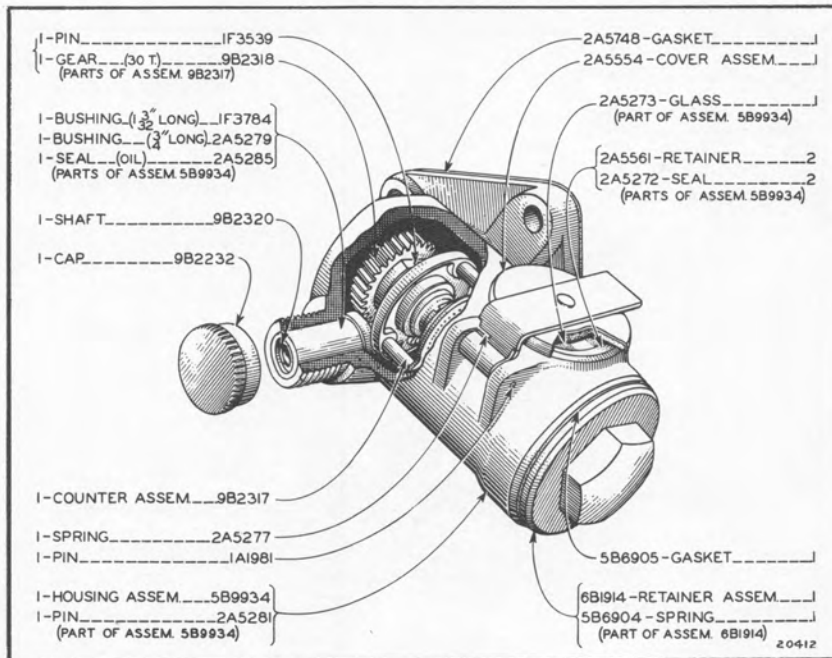

9B2321 Hour Meter and Tachometer Drive Group

Serial No. 9J5796SP to 9J5841SP, 3S9SP to 3S2000 and 8S5001 to 8S6183 Inclusive

CATERPILLAR D17000 DIESEL ENGINE

Always give engine serial number when ordering parts

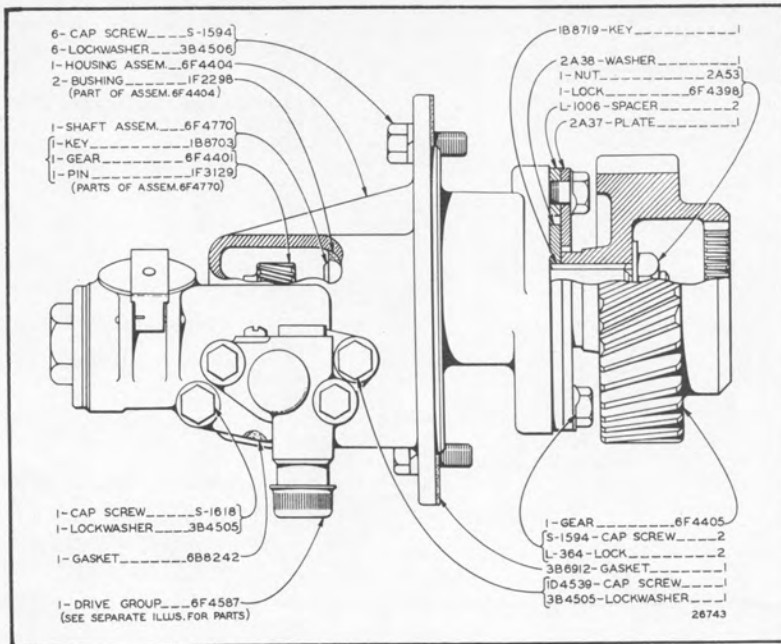

Hour Meter and Tachometer Drive
 Serial No. 8S6184 to 8S6799 Inclusive

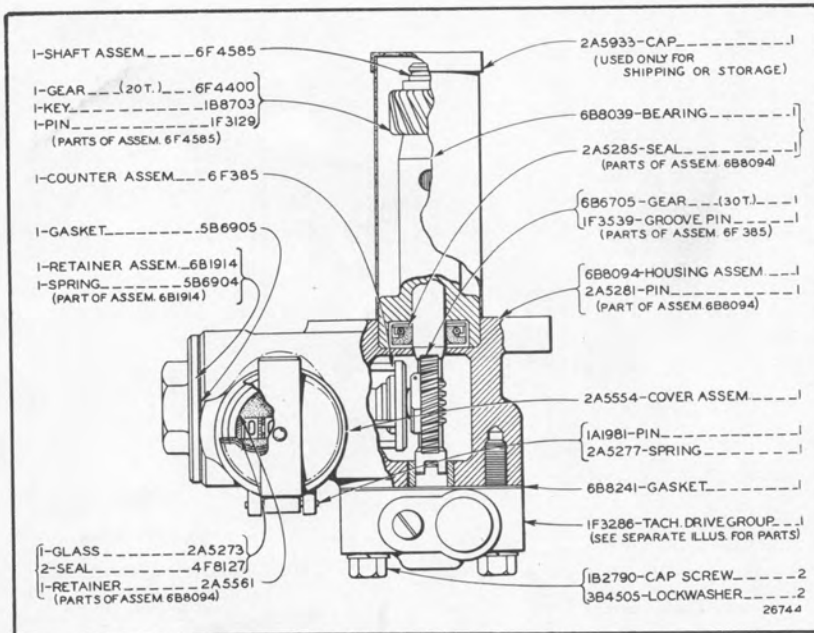

6F4587 Hour Meter and Tachometer Drive Group
 Serial No. 8S6184 to 8S6799 Inclusive

CATERPILLAR D17000 DIESEL ENGINE

GEG-3861D

Always give engine serial number when ordering parts

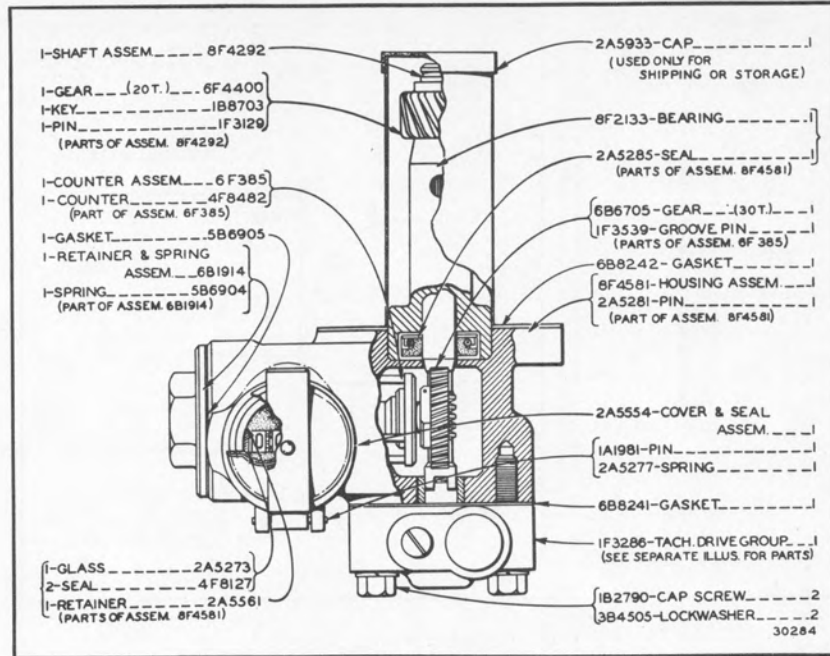

8F4293 Hour Meter and Tachometer Drive Group
 Effective with Serial No. 8S6800

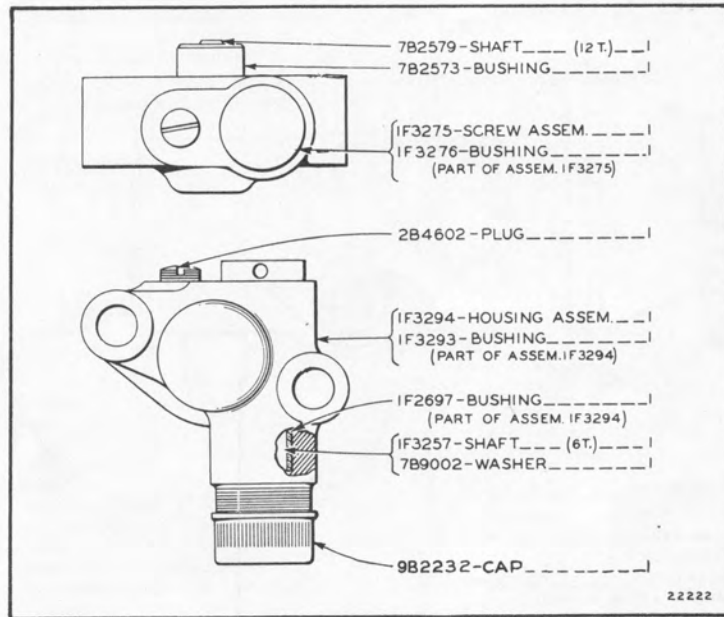

1F3286 Tachometer Drive Group
 Part of 6F4587 and 8F4293 Hour Meter and Tachometer Drive Group
 Effective with Serial No. 8S6184

CATERPILLAR D17000 DIESEL ENGINE

Always give engine serial number when ordering parts

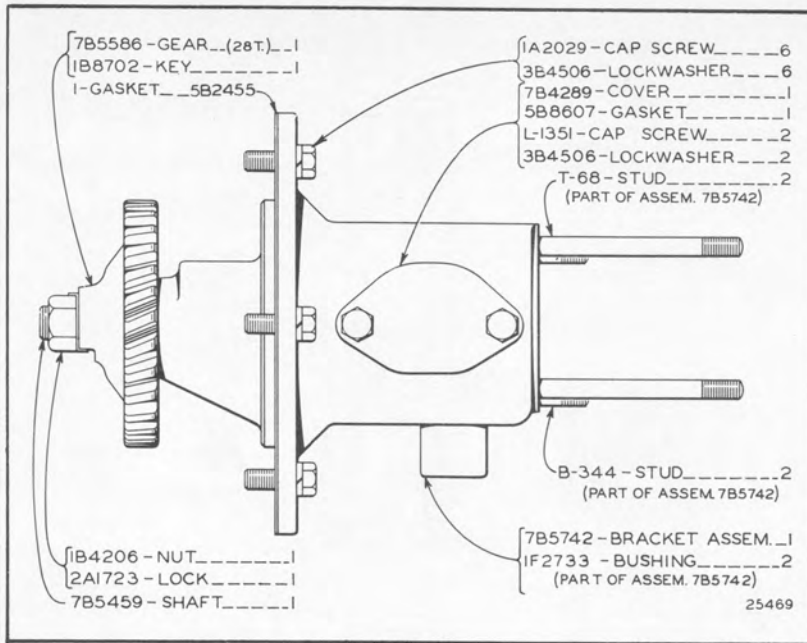

Fuel Transfer Pump Drive

Serial No. 9J5214SP to 9J6000SP, 3S1SP to 3S2000 Inclusive and 8S5001 to 8S6799 Inclusive

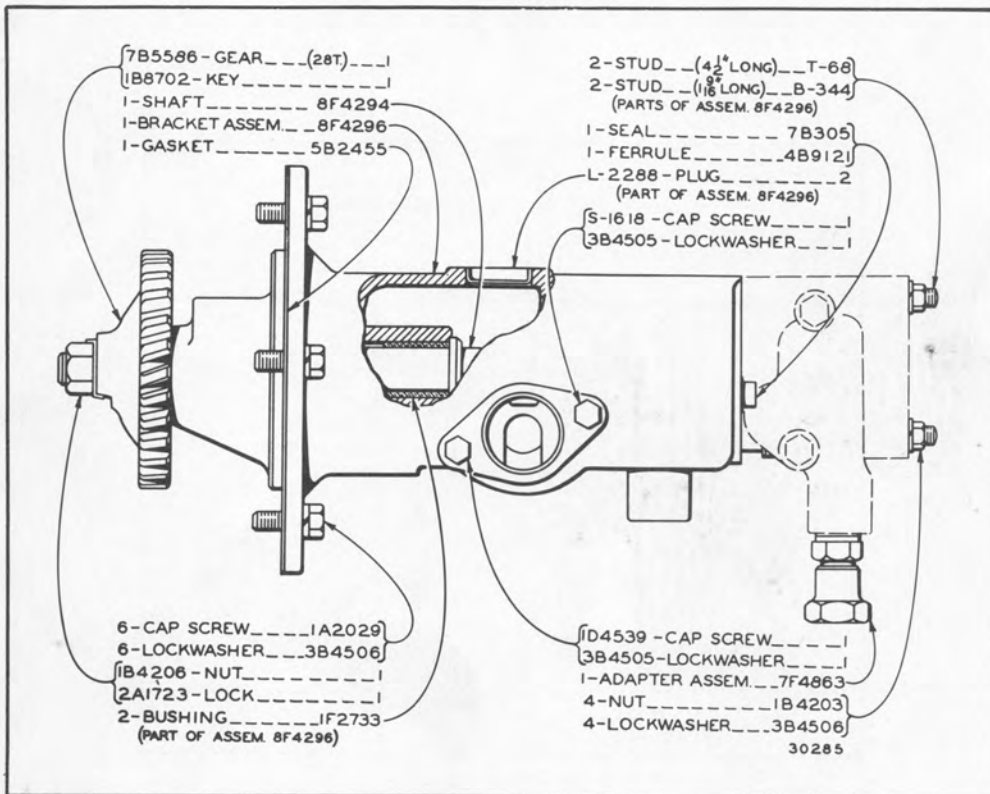

8F4297 Fuel Transfer Pump and Hour Meter Drive Group

Effective with Serial No. 8S6800

CATERPILLAR D17000 DIESEL ENGINE

GEG-3861D

Always give engine serial number when ordering parts

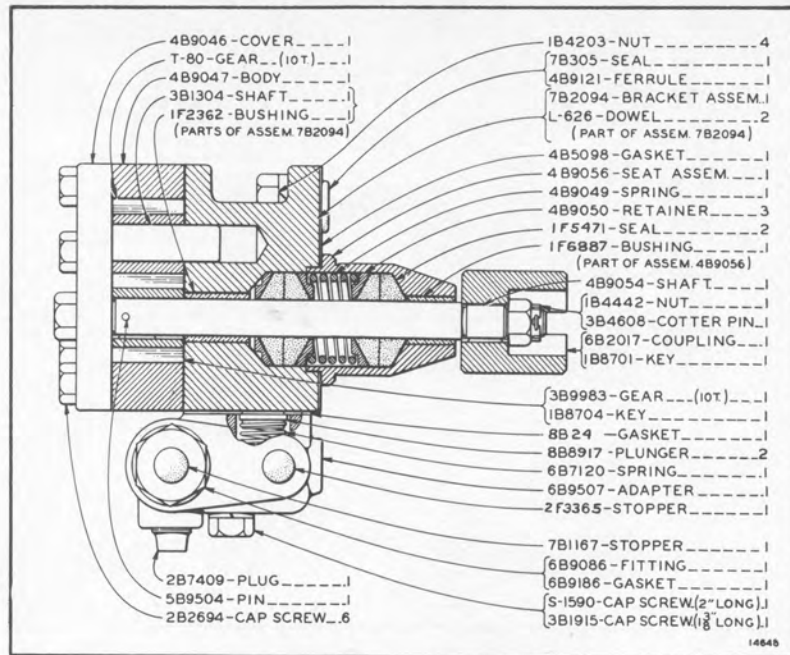

6B2018 Fuel Transfer Pump Group
 Serial No. 9J5144SP to 9J5213SP Inclusive

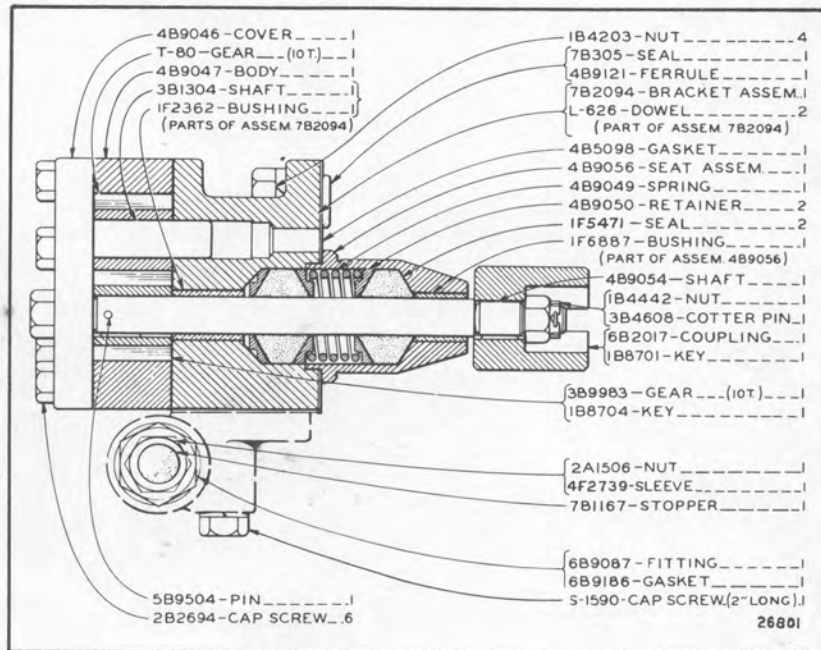

7B8198 Fuel Transfer Pump Group
 Serial No. 9J5214SP to 9J6000SP, 3S1SP to 3S2000 Inclusive and
 8S5001 to 8S6799 Inclusive

CATERPILLAR D17000 DIESEL ENGINE

Always give engine serial number when ordering parts

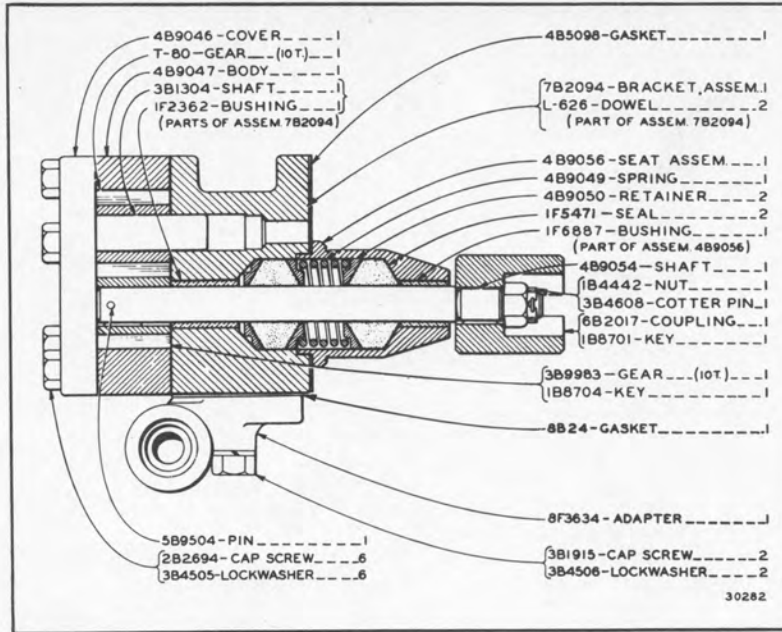

8F3531 Fuel Transfer Pump Group
 Effective with Serial No. 8S6800

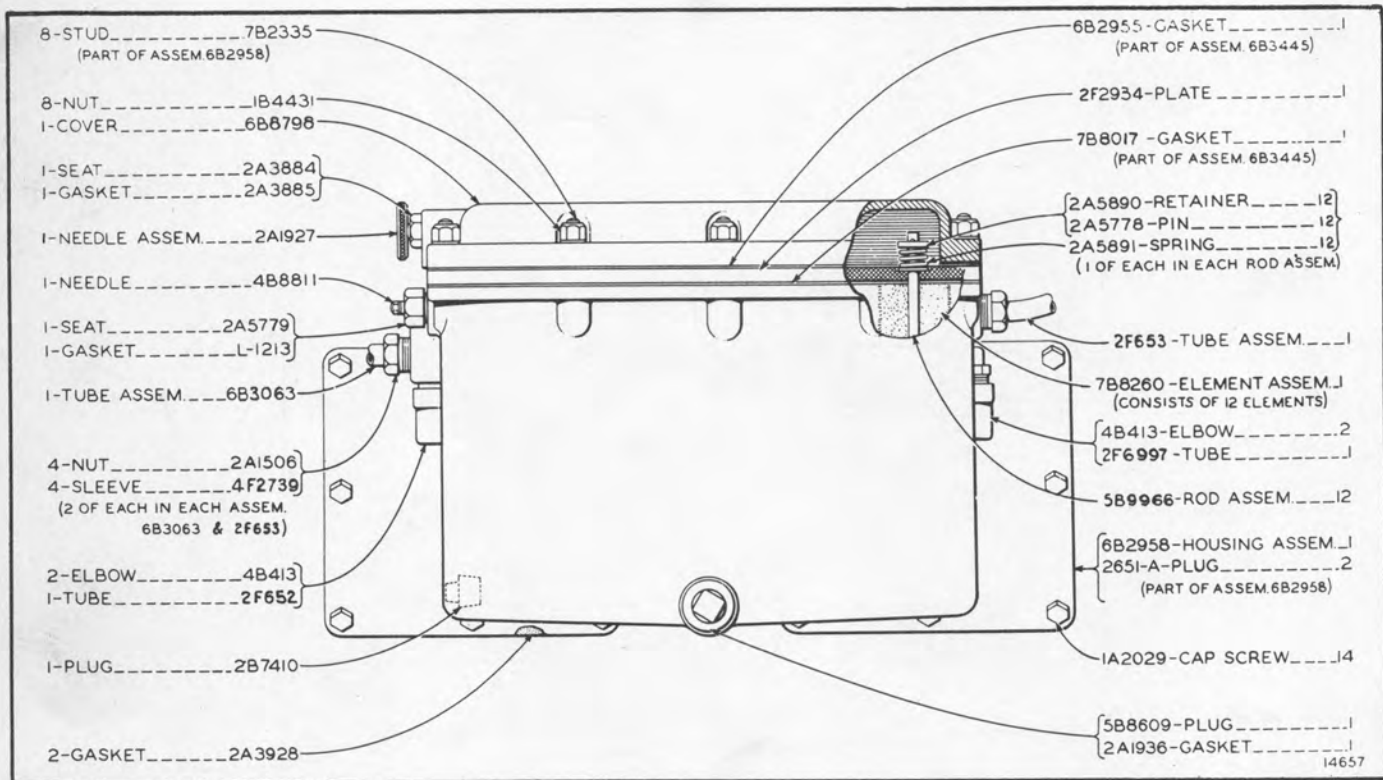

Fuel Filter
 Serial No. 9J5144SP to 9J5213SP Inclusive

CATERPILLAR D17000 DIESEL ENGINE

GEG-3861D

Always give engine serial number when ordering parts

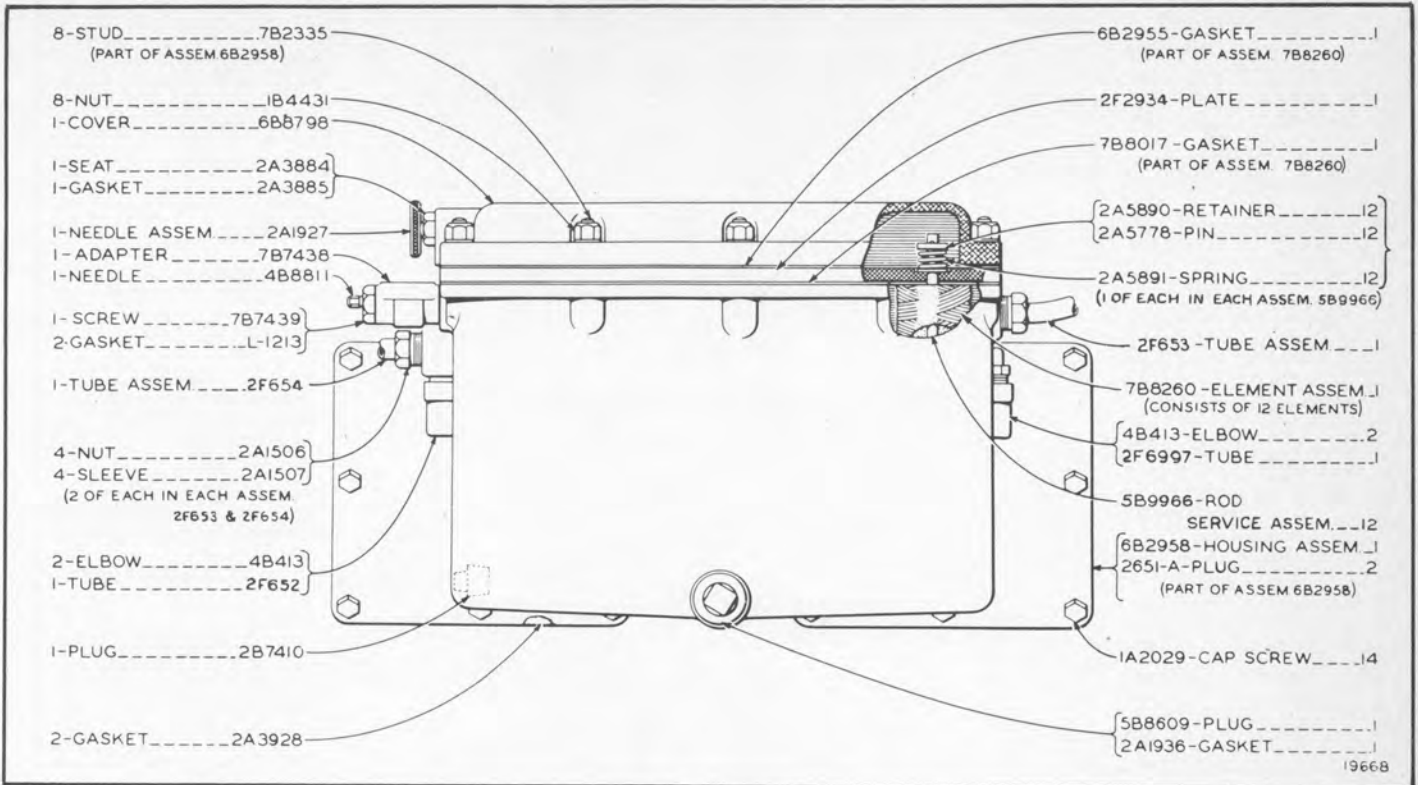

Fuel Filter

Serial No. 9J5214SP to 9J5272SP Inclusive

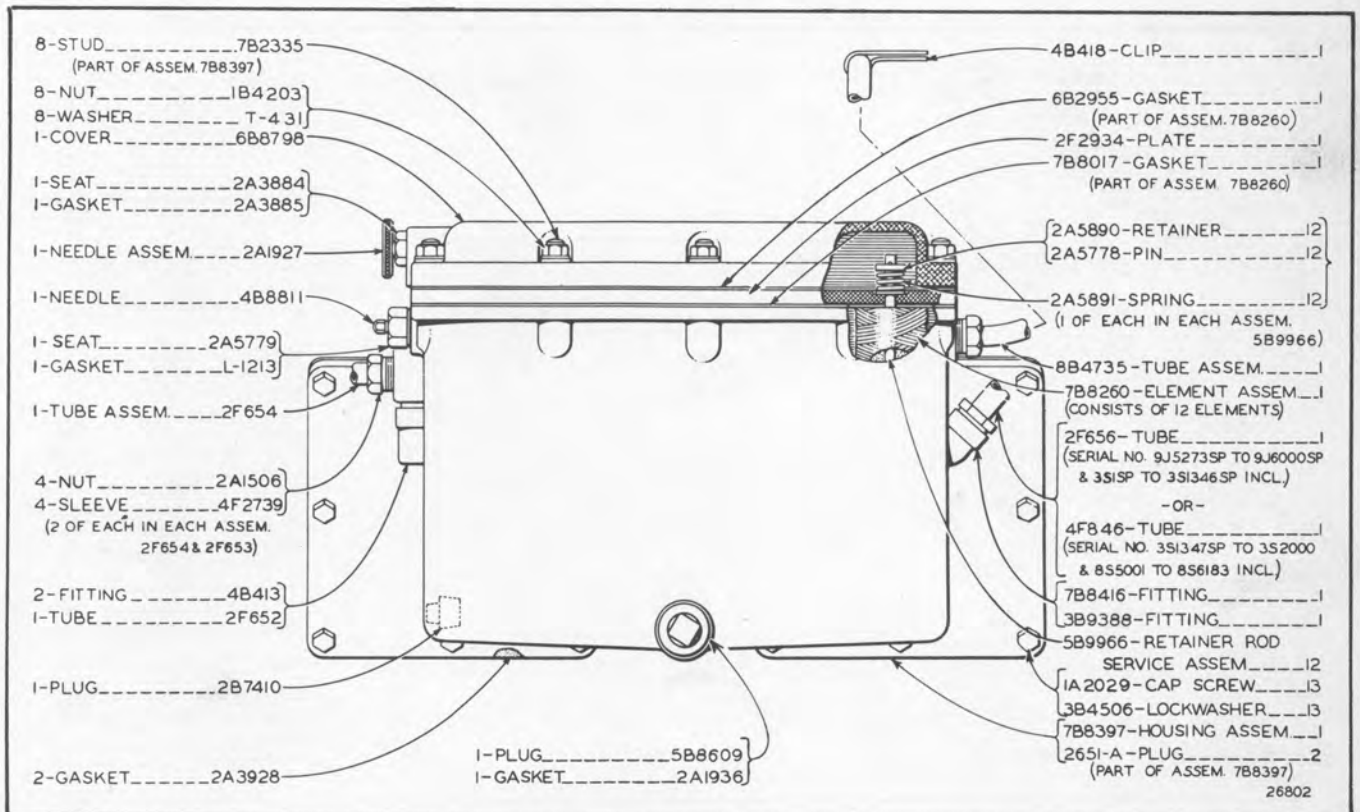

Fuel Filter

Serial No. 9J5273SP to 9J6000SP, 3S1SP to 3S2000 and 8S5001 to 8S6183 Inclusive

CATERPILLAR D17000 DIESEL ENGINE

Always give engine serial number when ordering parts

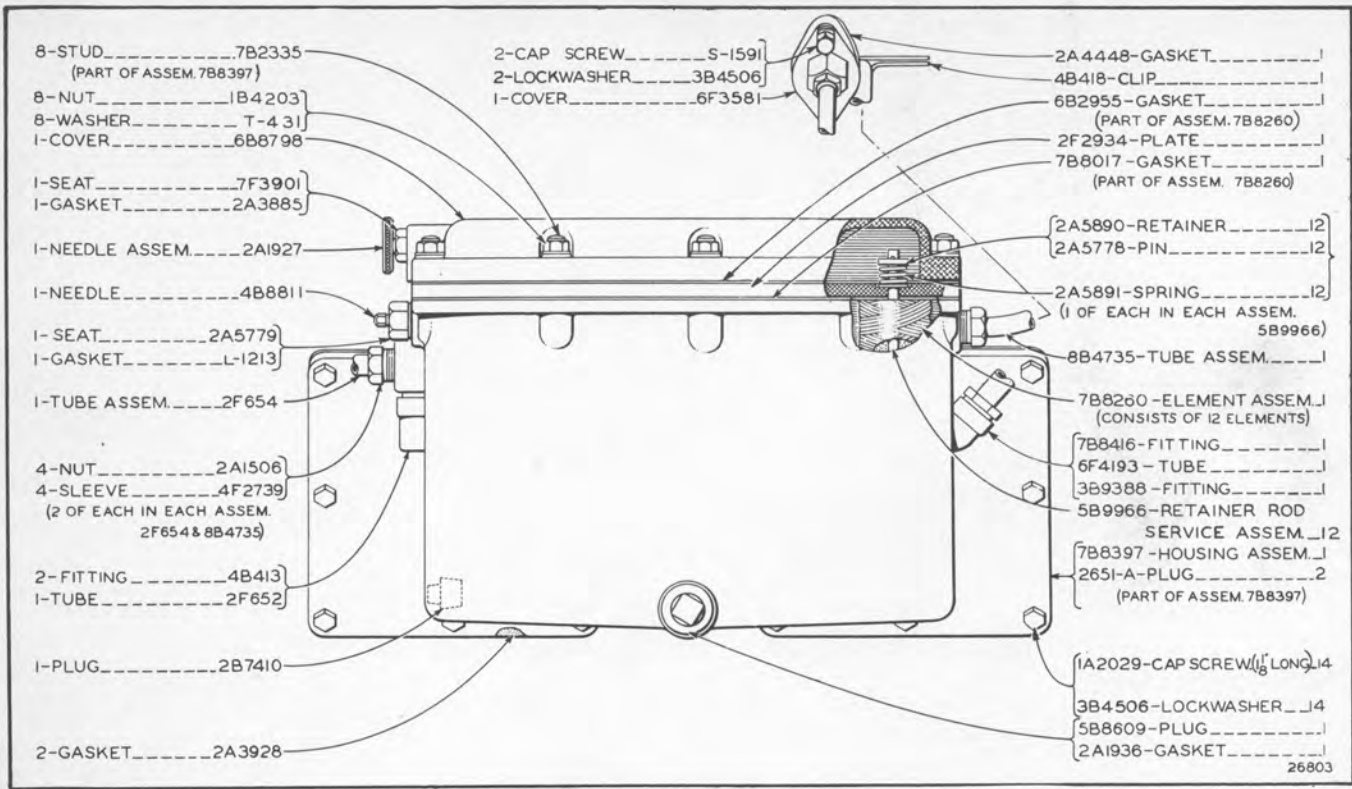

Fuel Filter

Serial No. 8S6184 to 8S6799 Inclusive

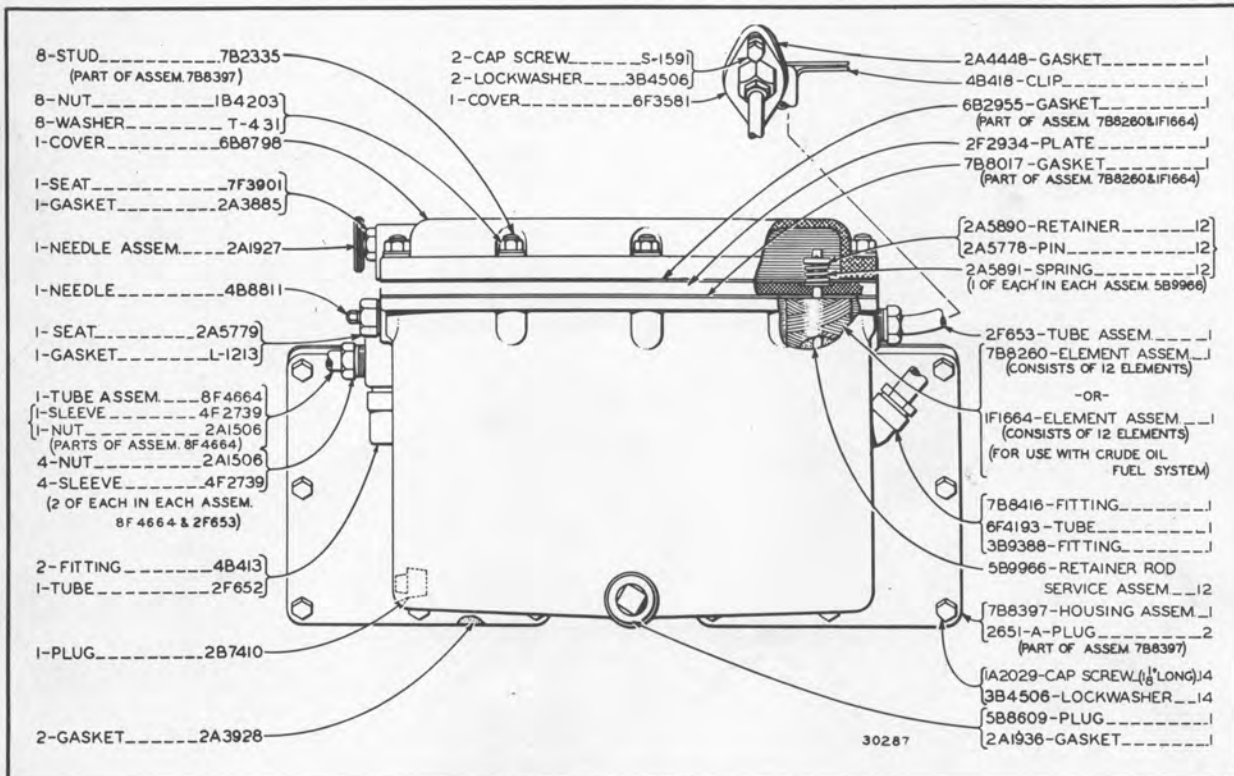

Fuel Filter

Effective with Serial No. 8S6800

CATERPILLAR D17000 DIESEL ENGINE

GEG-3861D

Always give engine serial number when ordering parts

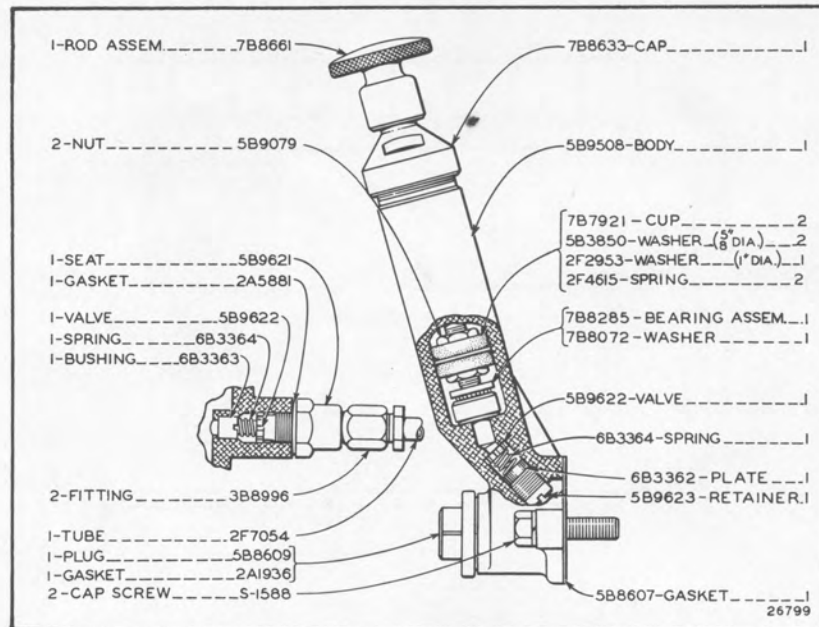

6B3120 Fuel Priming Pump Group

Only separate parts serviced
Serial No. 9J5144SP to 9J5213SP Inclusive

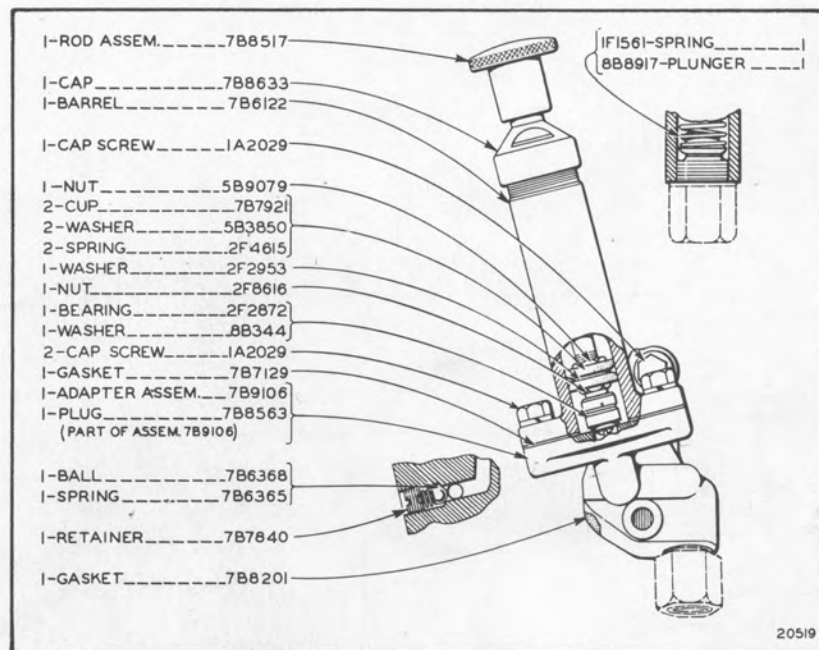

7B8565 Fuel Priming Pump Group

Serial No. 9J5214SP to 9J6000SP, 3S1SP to 3S2000 Inclusive and 8S5001-Up

CATERPILLAR D17000 DIESEL ENGINE

Always give engine serial number when ordering parts

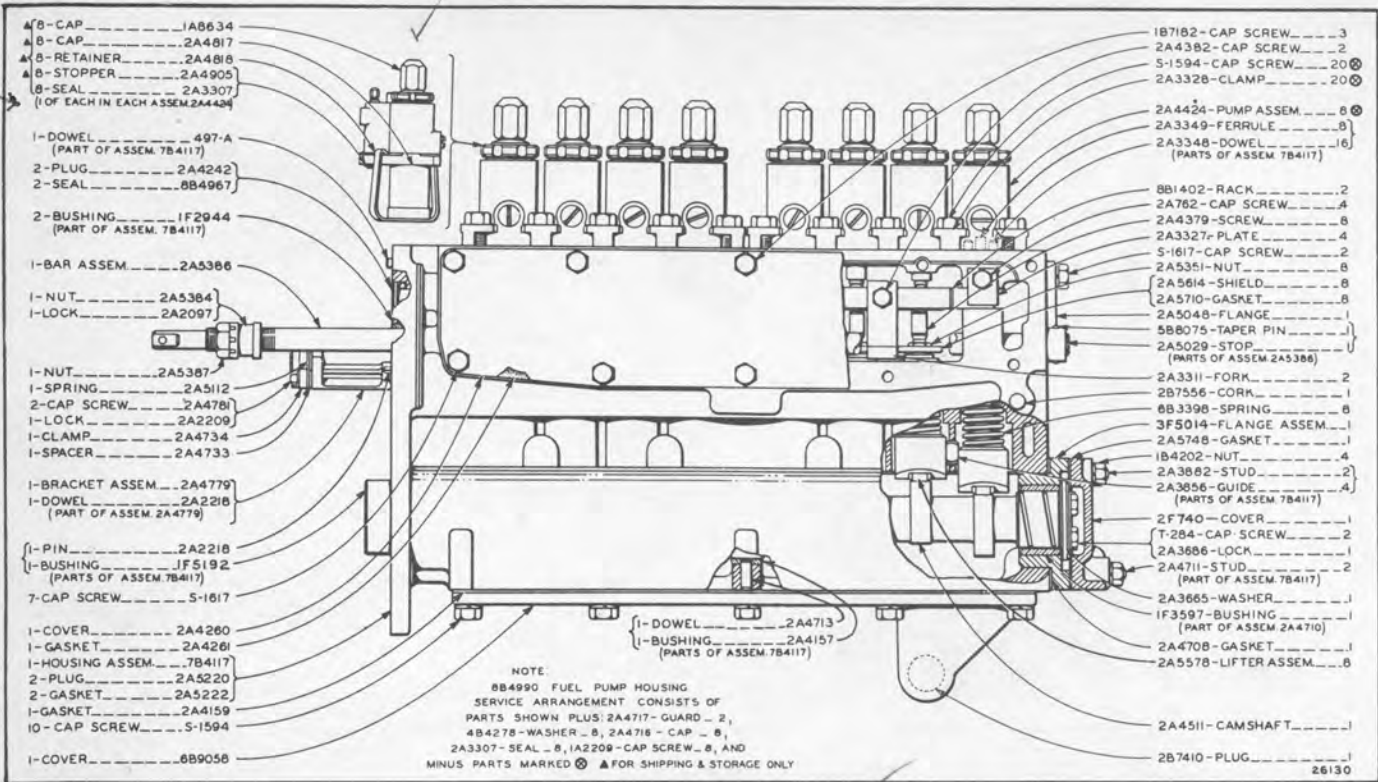

Fuel Pump Housing

Fuel Pump Housing Serial No. 8P735 to 8P1500 Inclusive

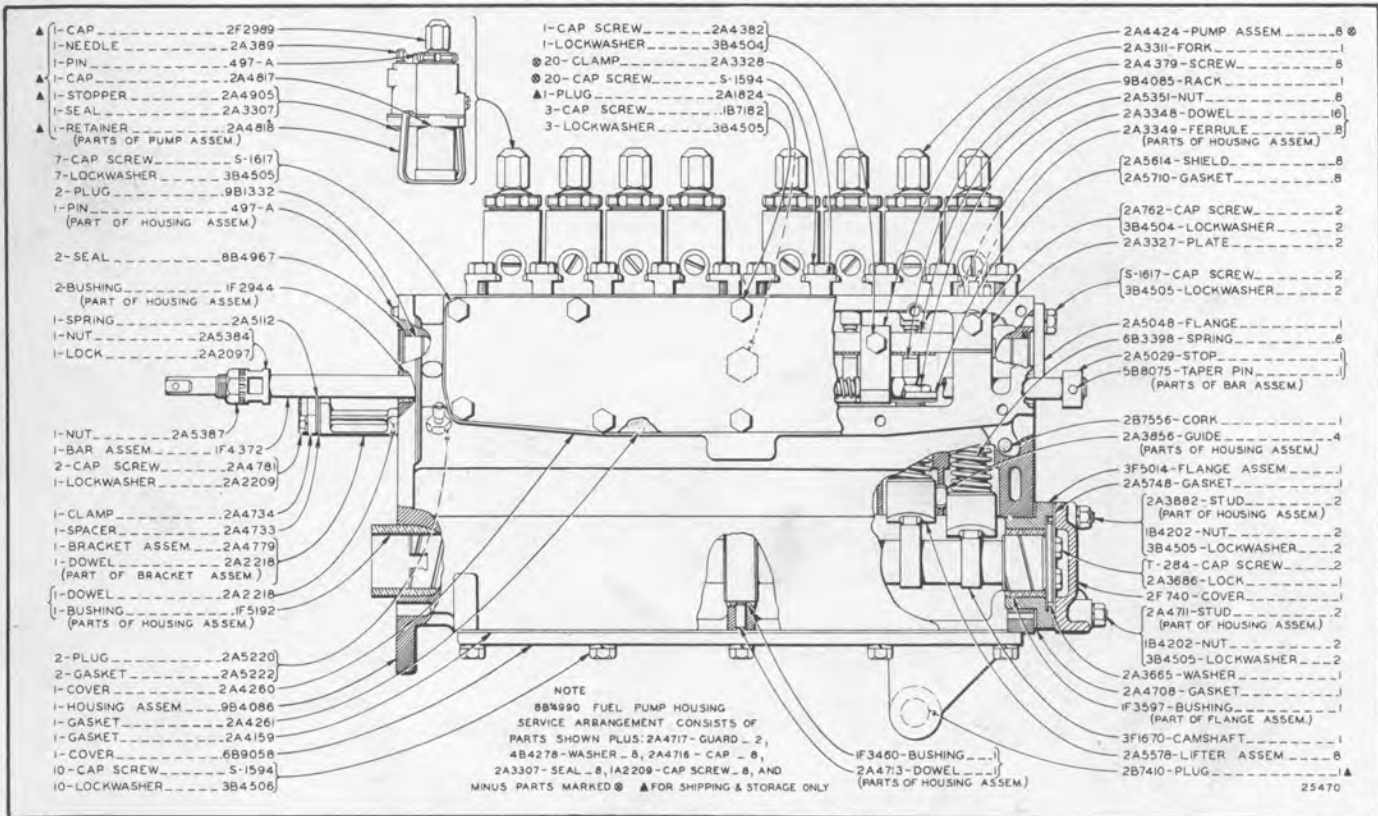

Fuel Pump Housing

Fuel Pump Housing Serial No. 8P1501-Up

CATERPILLAR D17000 DIESEL ENGINE

GEG-3861D

Always give engine serial number when ordering parts

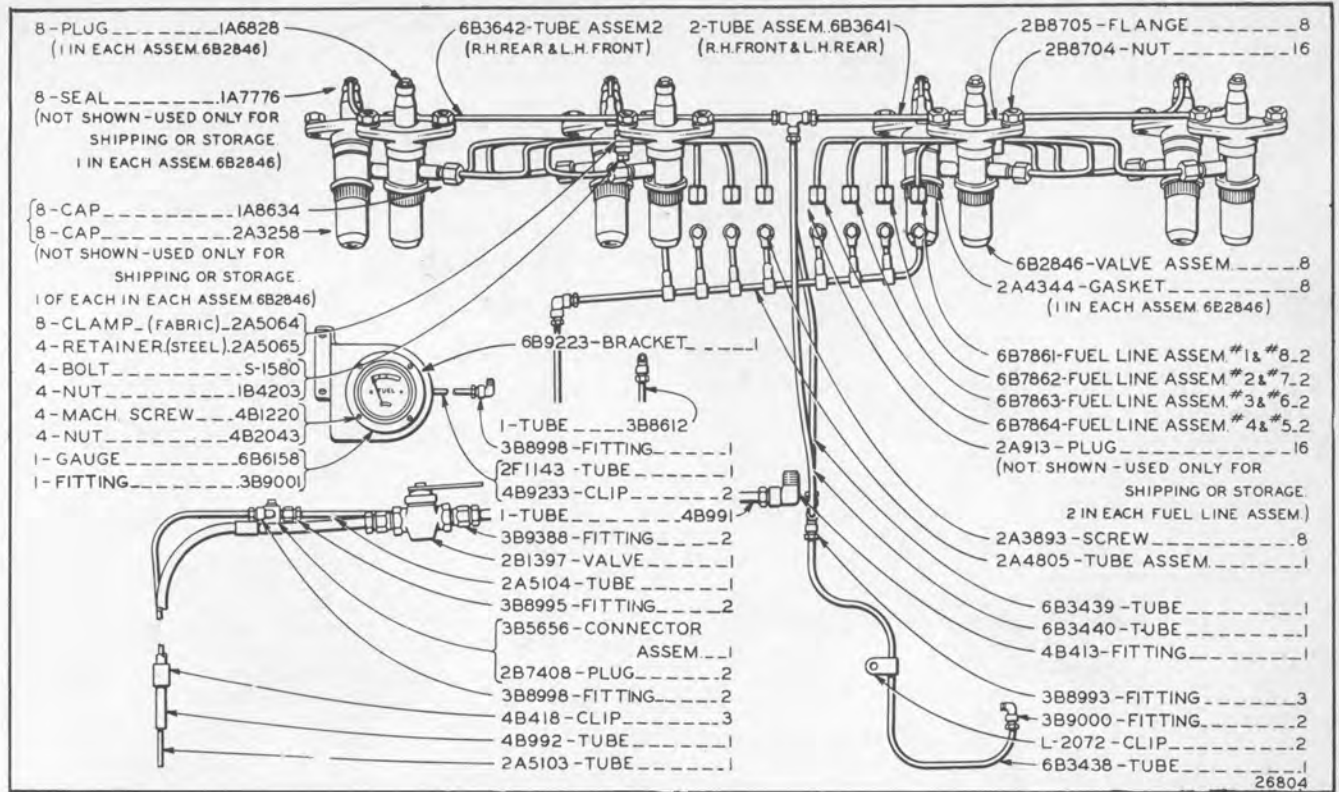

Fuel Injection Valves and Lines
Serial No. 9J5144SP to 9J5198SP Inclusive

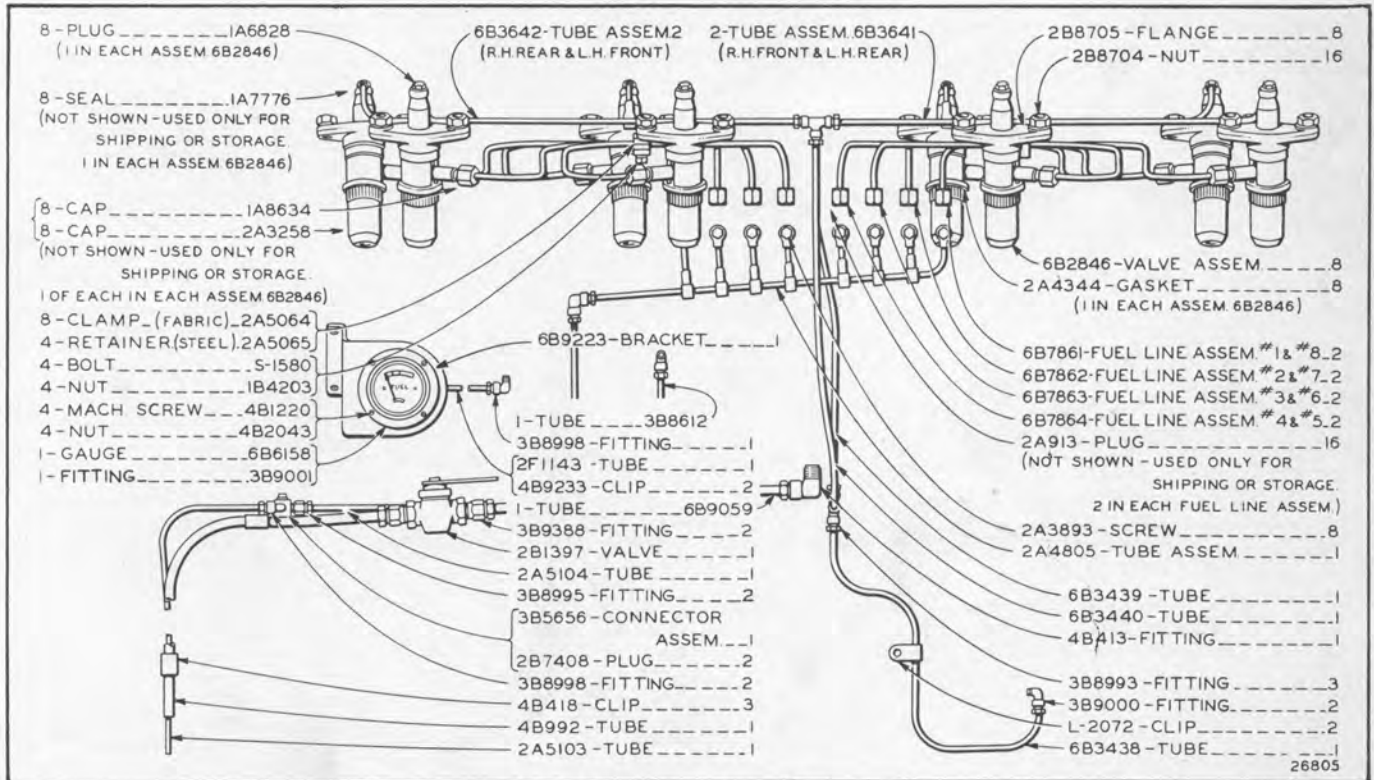

Fuel Injection Valves and Lines
Serial No. 9J5199SP to 9J5213SP Inclusive

CATERPILLAR D17000 DIESEL ENGINE

Always give engine serial number when ordering parts

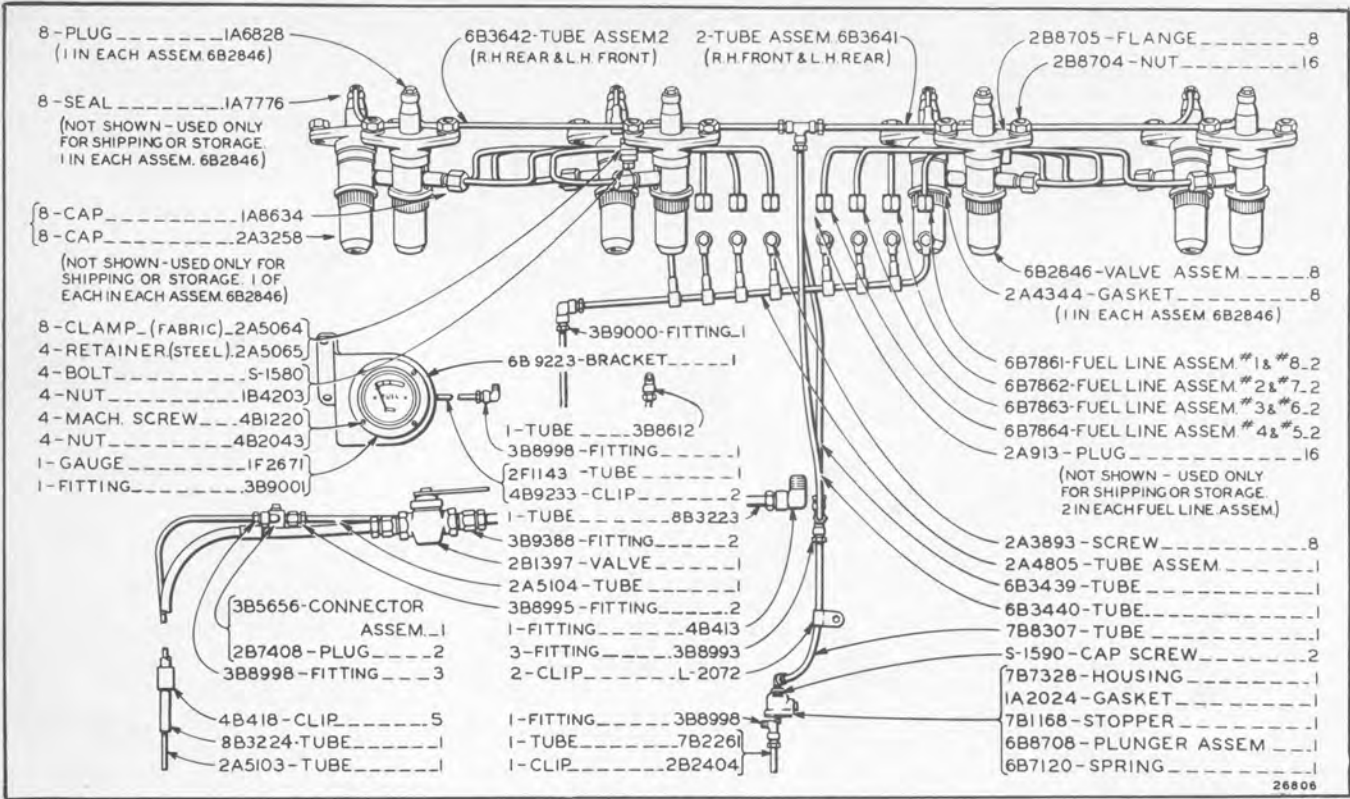

Fuel Injection Valves and Lines
Serial No. 9J5214SP to 9J5272SP Inclusive

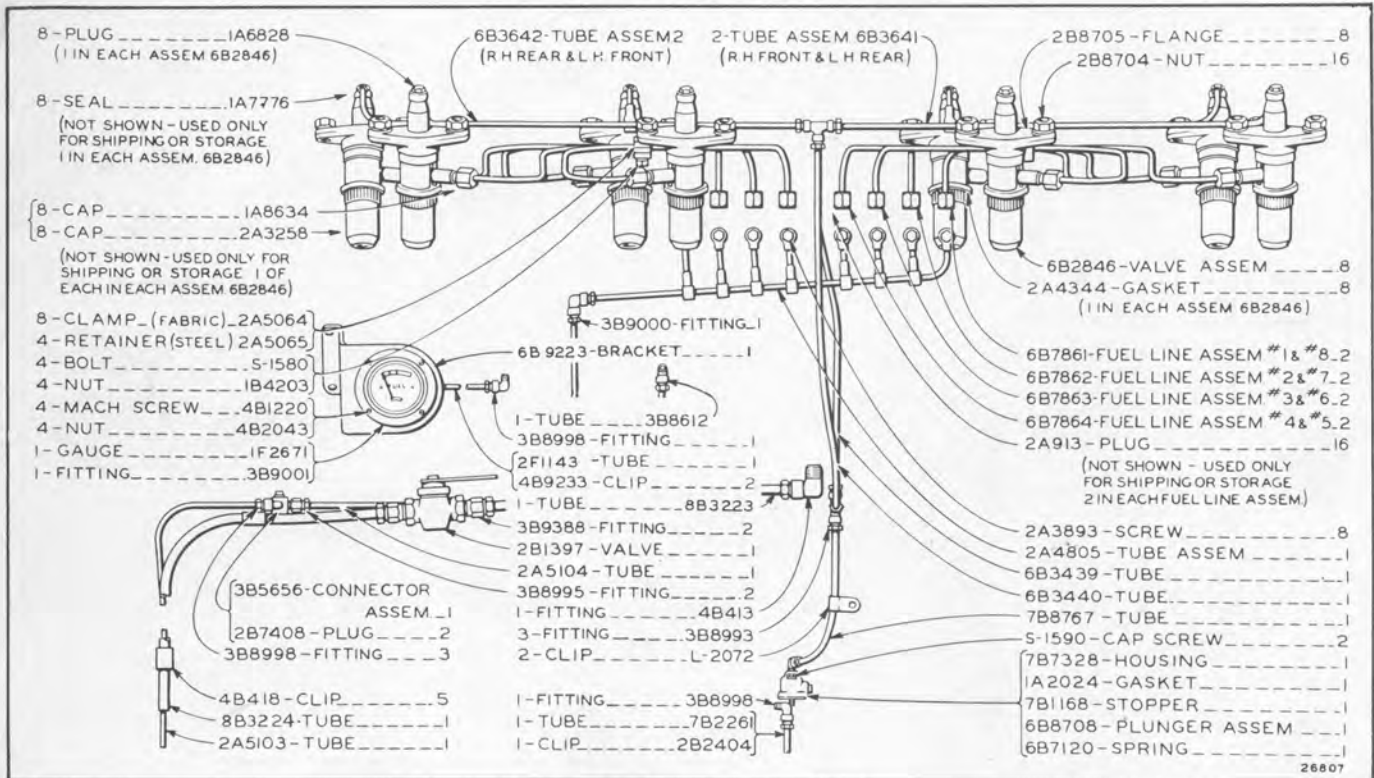

Fuel Injection Valves and Lines
Serial No. 9J5273SP to 9J5405SP Inclusive

CATERPILLAR D17000 DIESEL ENGINE

GEG-3861D

Always give engine serial number when ordering parts

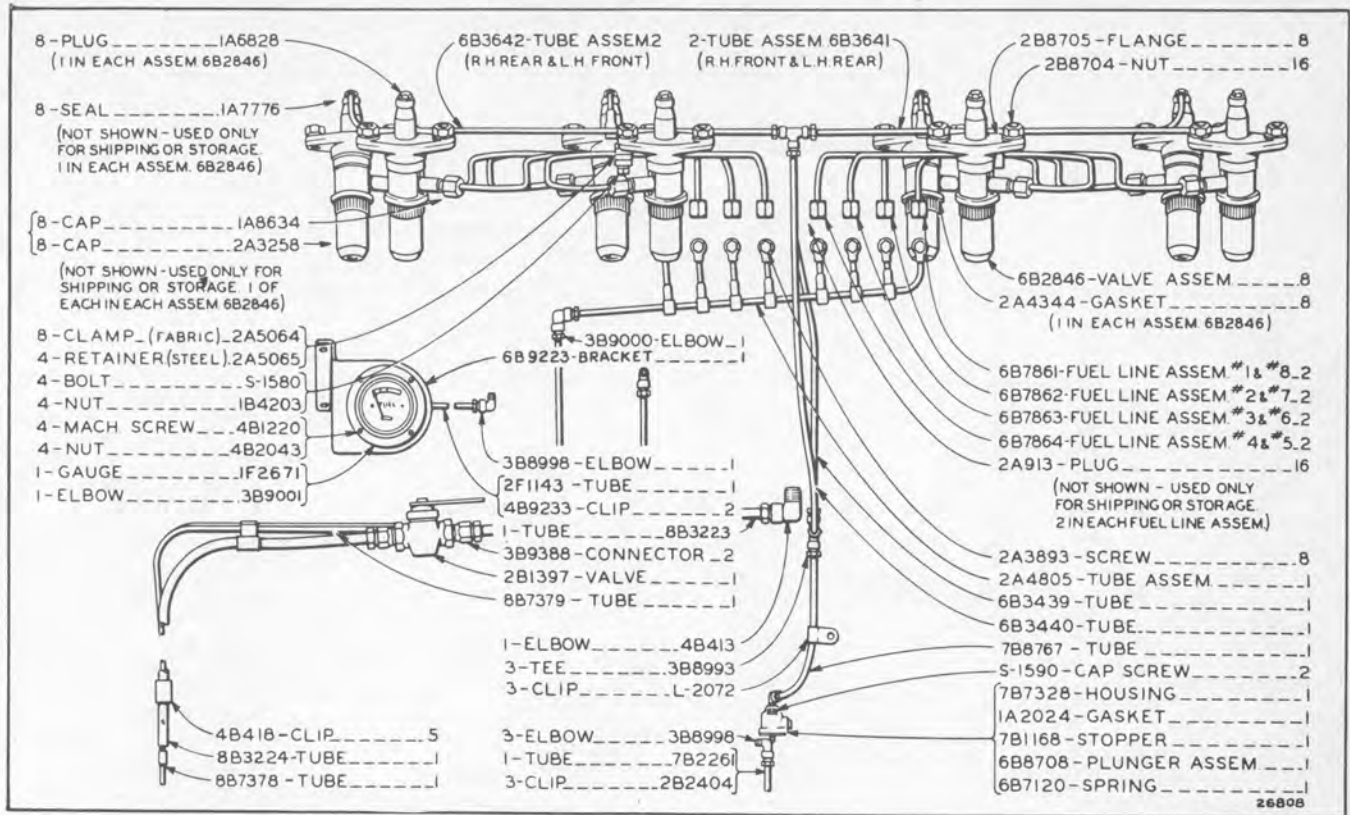

Fuel Injection Valves and Lines

Serial No. 9J5406SP to 9J6000SP and 3S1SP to 3S286SP Inclusive

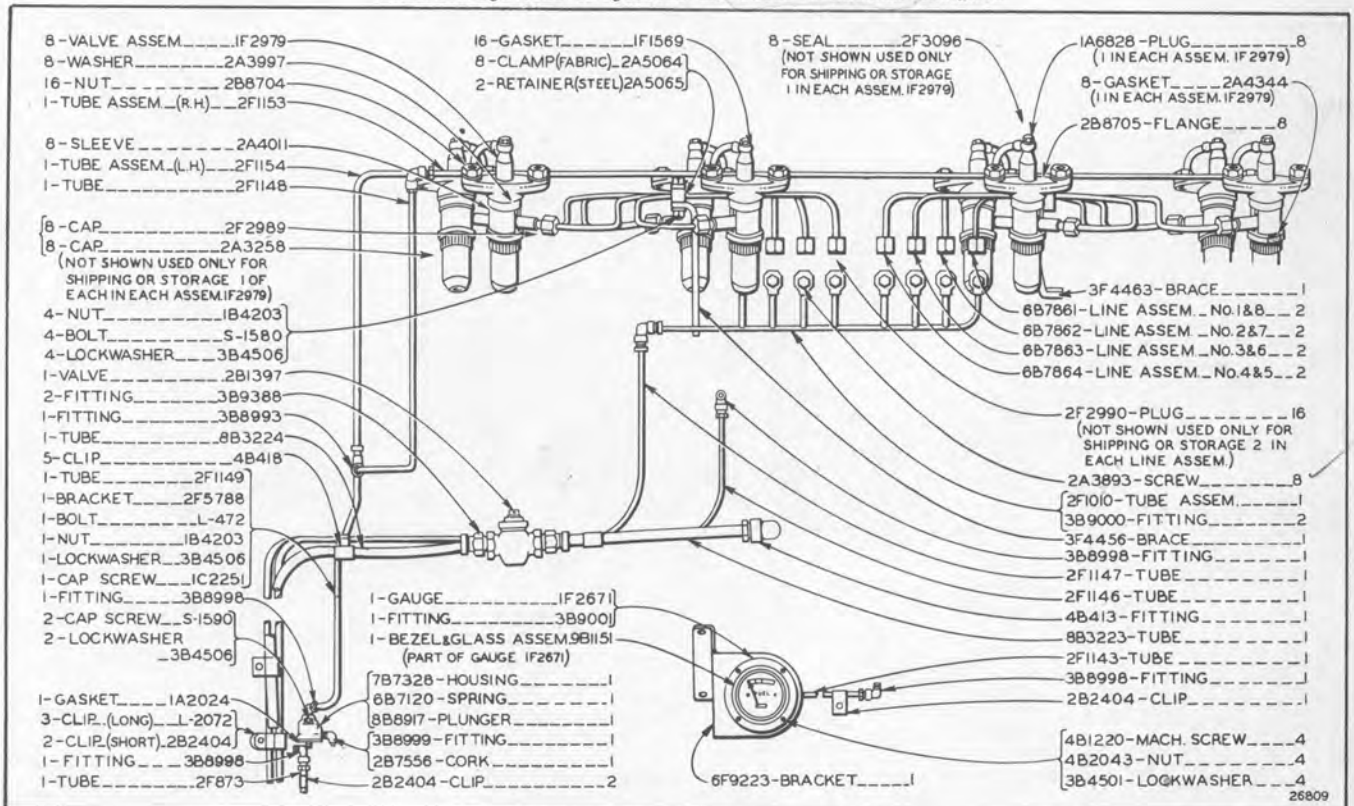

Fuel Injection Valves and Lines

Serial No. 3S287SP to 3S2000 Inclusive and 8S5001 to 8S6422 Inclusive

CATERPILLAR D17000 DIESEL ENGINE

Always give engine serial number when ordering parts

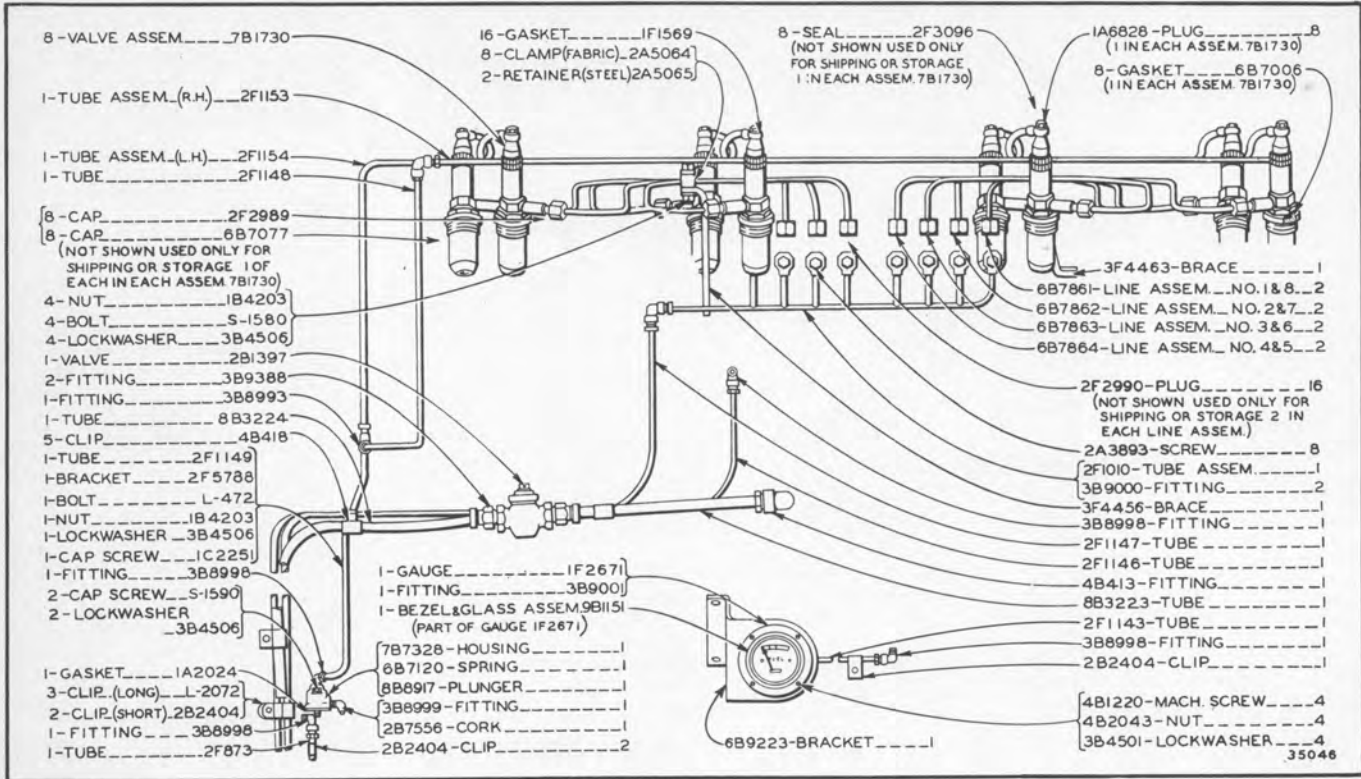

Fuel Injection Valves and Lines
 Effective with Serial No. 8S6423

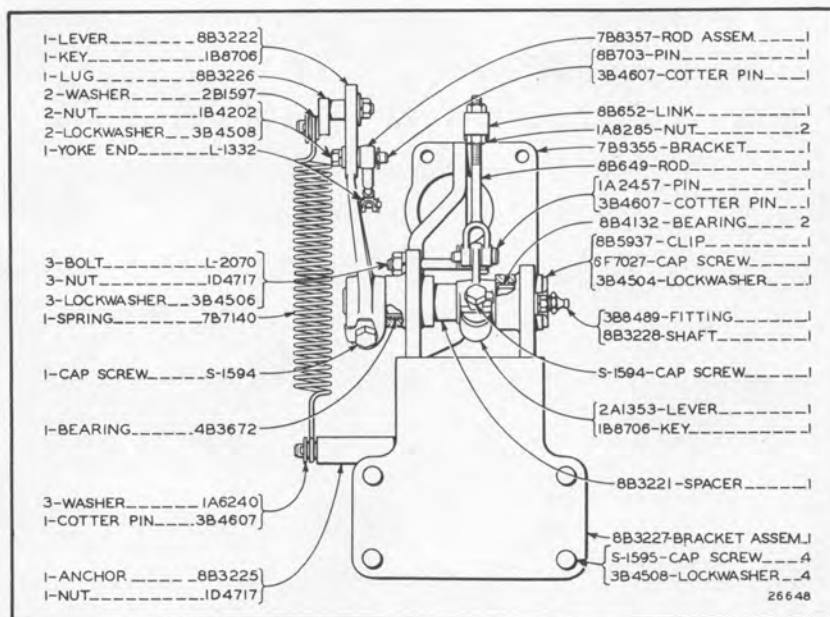

Fuel Pump and Governor Control Mechanism
 Serial No. 9J5144SP to 9J5306SP Inclusive

CATERPILLAR D17000 DIESEL ENGINE

GEG-3861D

Always give engine serial number when ordering parts

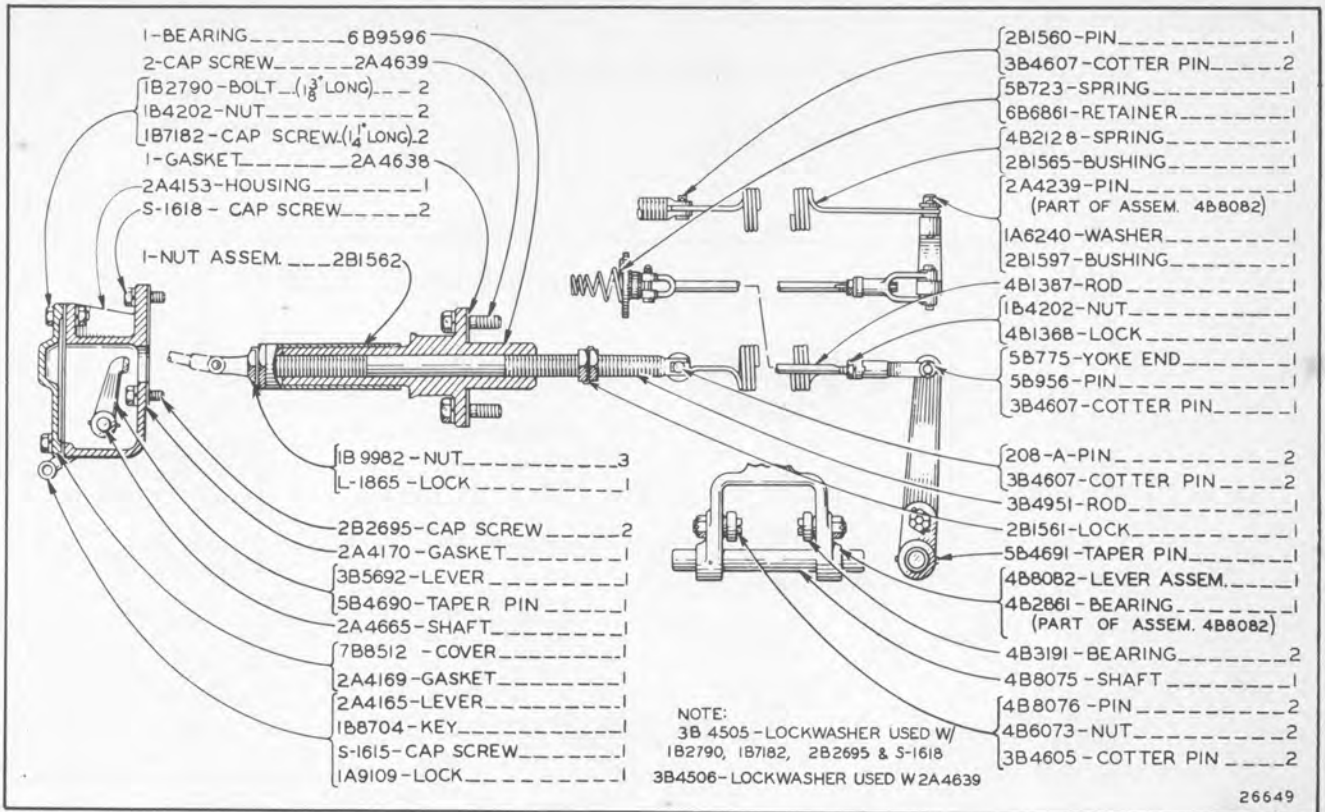

Fuel Pump and Governor Control Mechanism
 Serial No. 9J5144SP to 9J6000SP and 3S1SP to 3S182SP Inclusive

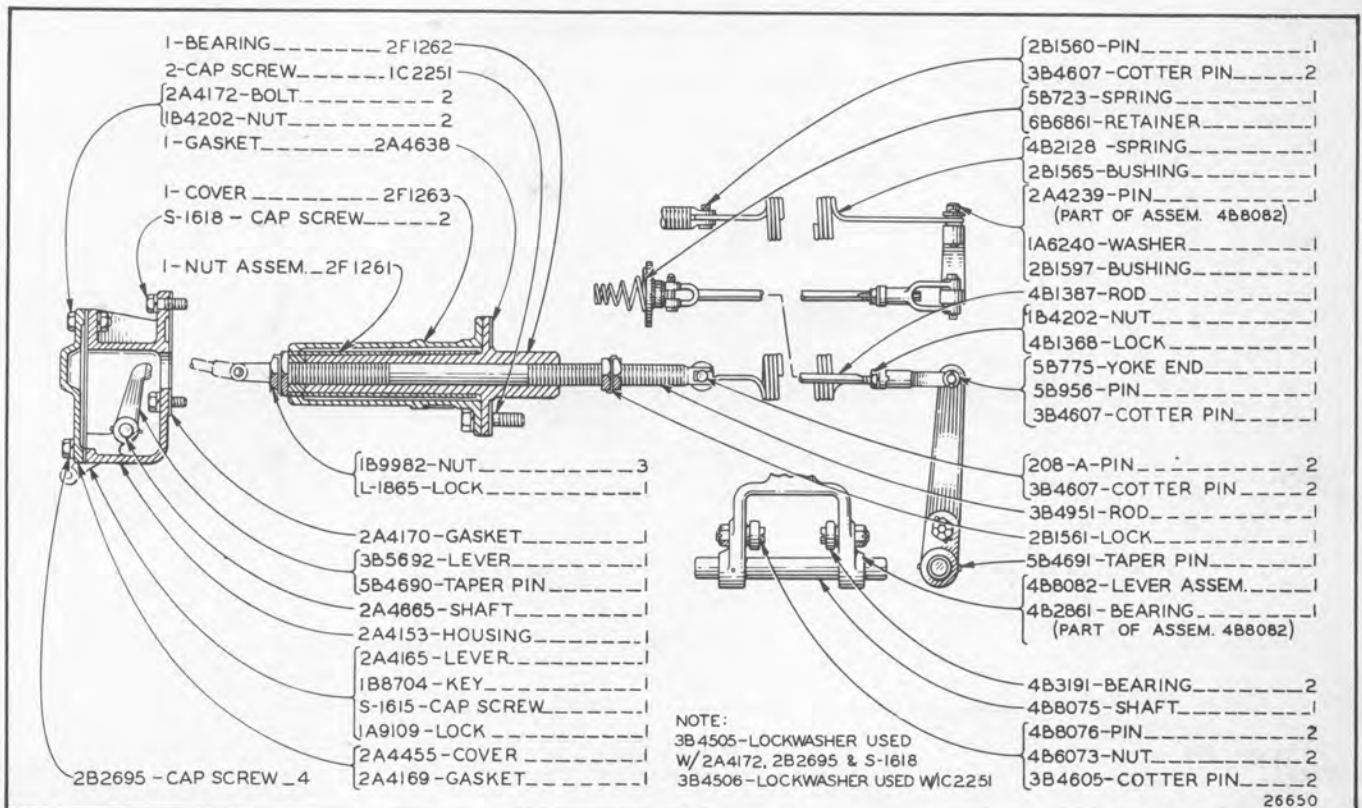

Fuel Pump and Governor Control Mechanism
 Serial No. 3S183SP to 3S2000 Inclusive and 8S5001-Up

CATERPILLAR D17000 DIESEL ENGINE

Always give engine serial number when ordering parts

8B3728 Safety Shut-off Arrangement

Consists of:

- 1 Water Temperature Shut-off..... Page 56
- 1 8B9898 Oil Pressure Shut-off Group..... Page 57

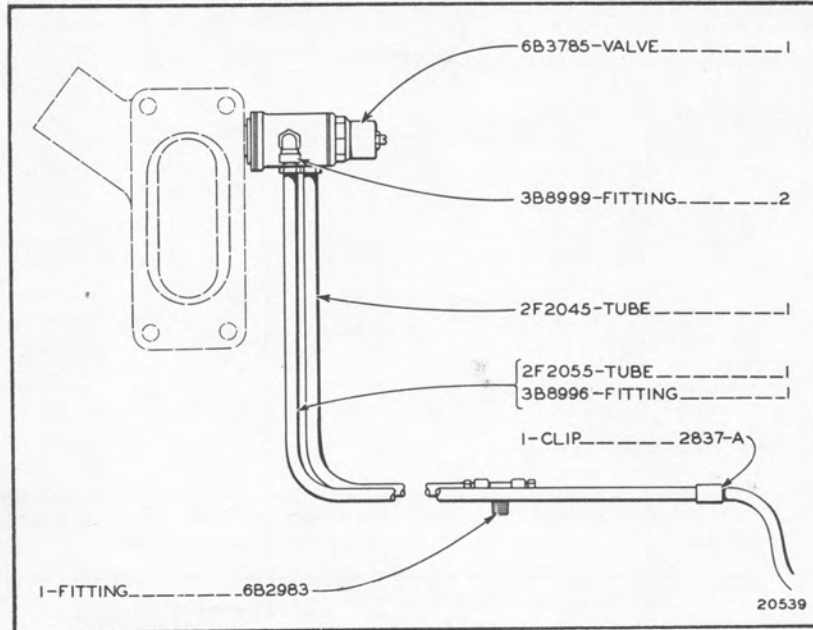

Water Temperature Shut-off Part of 8B3728 Safety Shut-off Arrangement

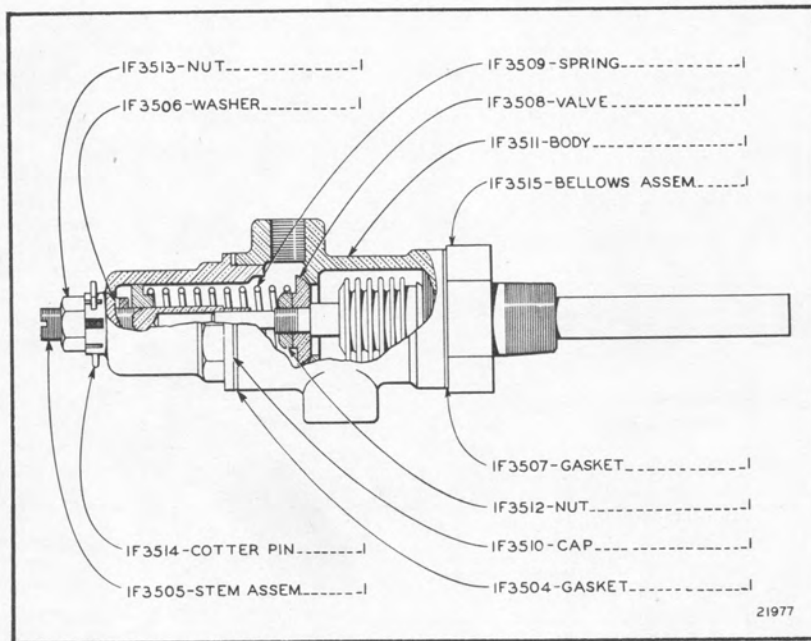

6B3785 Valve Part of Water Temperature Shut-off

CATERPILLAR D17000 DIESEL ENGINE

GEG-3861D

Always give engine serial number when ordering parts

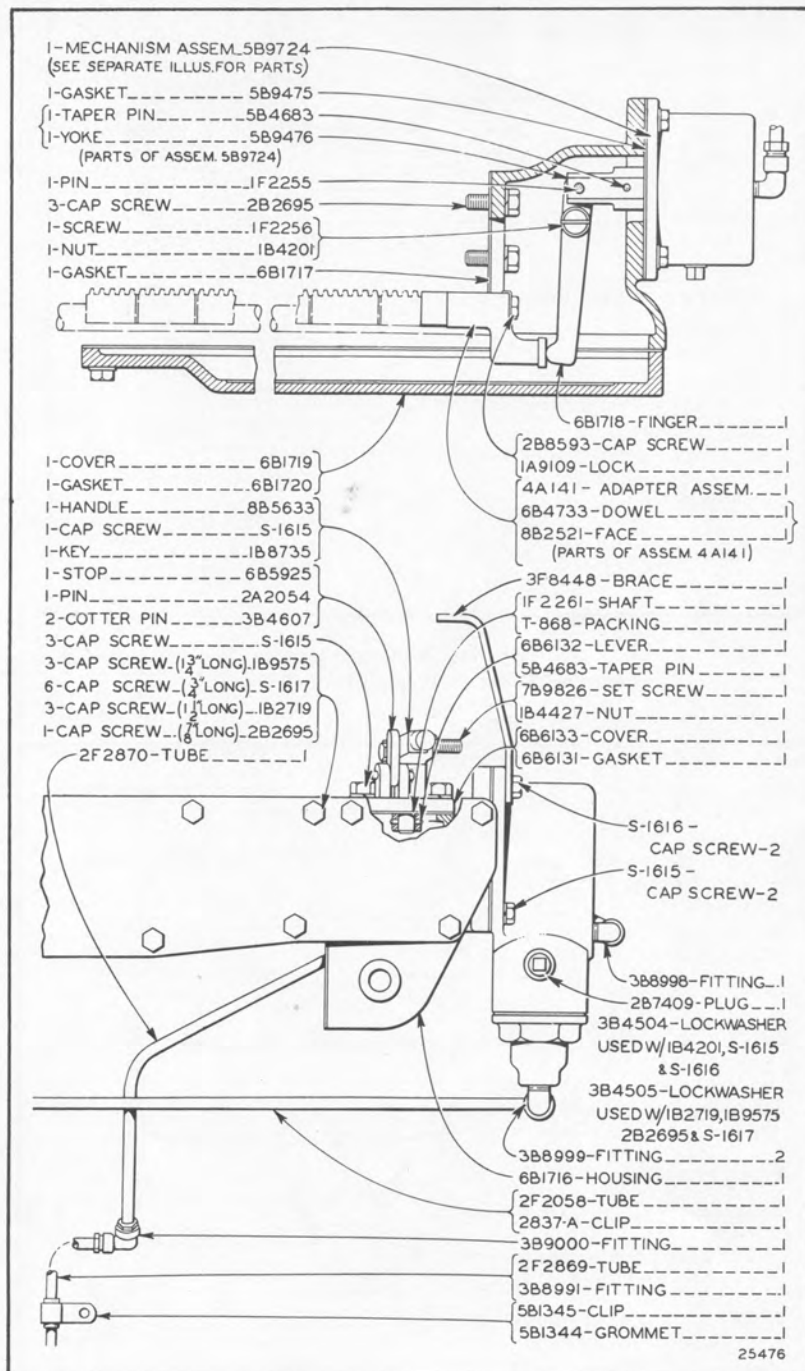

8B9898 Oil Pressure Shut-off Group
Part of 8B3728 Safety Shut-off Arrangement

CATERPILLAR D17000 DIESEL ENGINE

Always give engine serial number when ordering parts

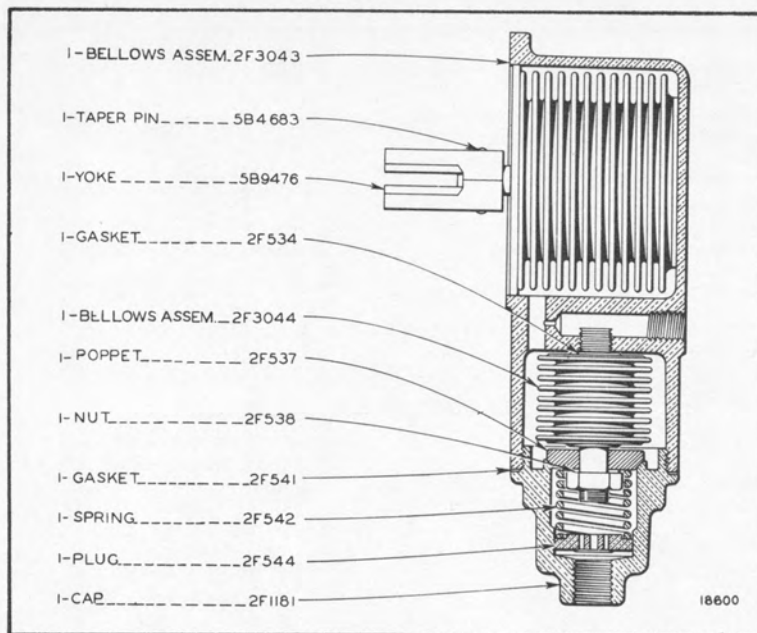

5B9724 Mechanism Assembly
 Part of 8B9898 Oil Pressure Shut-off Group

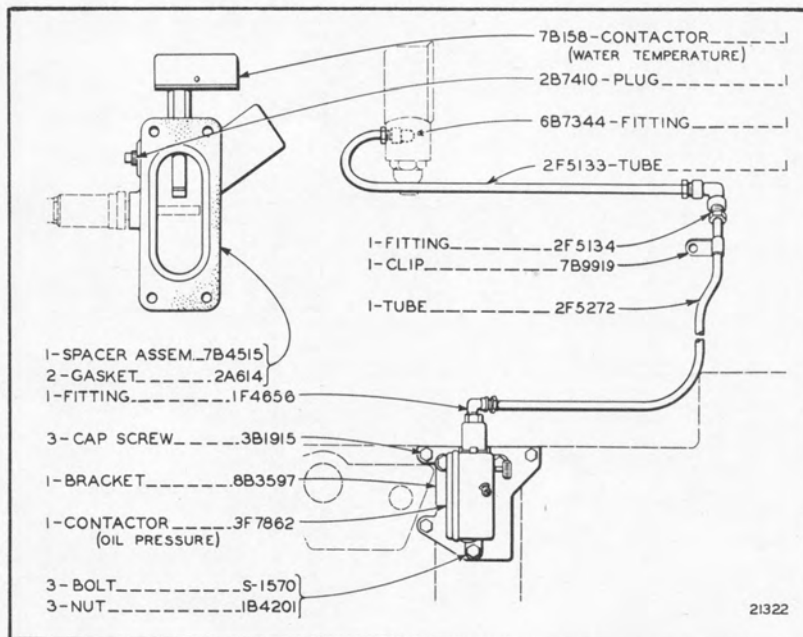

8B3600 Safety Alarm Group

CATERPILLAR D17000 DIESEL ENGINE

GEG-3861D

Always give engine serial number when ordering parts

Transfers and Nameplates

Quantity Used	Part Number	Description
1	1B1897	Plate—Serial Number On L.H. side of Cylinder Block—Rear
6	4B4159	Drive Screw
1	6B1919	Transfer—Lub. Oil Filter Instructions On Oil Filter Cover
1	6B2255	Transfer—Safety On dash or guards, when used
1	9B3425	Plate—Engine Name and Patent On L.H. side of Cylinder Block—Front
1	3F4136	Label—Certification On Oil Filter Body

CATERPILLAR D17000 DIESEL ENGINE

INDEX OF CATALOG NUMBERS

Catalog identifications in this index are arranged in order, reading from left to right, first alphabetically according to the prefix letter or letters, if used, and second numerically.

In this index all numbers with a letter prefix will precede those without prefixes.

The number of letters or digits does not affect placement in the table, thus A1999999 will precede A2, and ZZ9999999 will precede Cat. No. 1 (number without a prefix). Letters take precedence over numbers so that Cat. No. 26F1 will precede Cat. No. 261.

Cat. No.	Page	Cat. No.	Page	Cat. No.	Page	Cat. No.	Page	Cat. No.	Page
B344----	10, 44	T431-----	14, 37, 47, 48	1B4427--	57	1F1742--	32	1F5471--	45, 46
B702----	35, 36, 37	T495-----	9, 10, 11	1B4431--	46, 47	1F2015--	32	1F5965--	37, 38
L1002----	35	T68-----	10, 44	1B4439--	5	1F2017--	32	1F6887--	45, 46
L1006----	9, 10, 11, 42	T80-----	45, 46	1B4441--	14	1F2020--	32	1F929--	37, 38
L1026----	19, 29	T868-----	57	1B4442--	45, 46	1F2021--	32	1F967--	8
L1141----	22, 23	T924-----	6, 7, 12, 13, 14	1B4906--	29	1F2044--	32	2A1162--	11
L1143----	7, 40, 41	V114-----	18, 19	1B5174--	22, 23	1F2047--	32	2A1230--	15, 16, 17, 22
L1166----	15, 16, 17, 22	V196-----	12, 13	1B5355--	12	1F2048--	32	2A1278--	35, 36, 37
L1213----	46, 47, 48	1A1460--	30	1B5358--	12	1F2162--	32	2A1279--	35, 36, 37
L1332----	54	1A1633--	35, 36, 37	1B5696--	18, 19	1F2238--	40, 41	2A1341--	39
L1351----	11, 22, 23, 24, 44	1A1721--	14, 39	1B5932--	22, 23	1F2255--	57	2A1353--	35, 36, 37, 54
L1365----	19	1A1890--	20	1B6867--	29	1F2256--	57	2A1432--	18, 19
L1686----	29	1A1917--	30, 31	1B6894--	35, 36	1F2261--	57	2A1433--	18, 19
L1865----	55	1A1935--	15, 16, 17, 18	1B7182--	50, 55	1F2298--	42	2A1506--	45, 46, 47, 48
L2061----	19, 20, 21	1A1981--	40, 41, 42, 43	1B7482--	6, 7	1F2362--	45, 46	2A1507--	47
L2070----	8, 35, 36, 37, 54	1A2024--	52, 53, 54	1B7960--	19, 20	1F2671--	52, 53, 54	2A1553--	12, 13
L2072----	51, 52, 53, 54	1A2029--	5, 7, 8, 11, 12, 14, 15, 16, 17, 18, 19, 23, 24, 25, 26, 44, 46, 47, 48, 49	1B7961--	19, 20	1F2690--	24	2A1634--	24
L2119----	35, 36, 37	1A2036--	21	1B8082--	9, 10, 11	1F2697--	43	2A1635--	24
L2288----	44	1A2040--	19, 20, 21	1B8083--	9, 10, 11	1F2733--	44	2A1640--	24
L2332----	26	1A2041--	21	1B8088--	9, 10, 11	1F2874--	26	2A1719--	30, 31
L364----	9, 10, 11, 14, 23, 24, 39, 42	1A2209--	50	1B8701--	45, 46	1F2891--	23	2A1723--	44
L468----	6, 7, 9, 10, 11	1A2457--	35, 36, 37, 54	1B8702--	10, 40, 41, 44	1F2892--	23	2A1824--	50
L472----	8, 53, 54	1A2658--	37, 38	1B8703--	42, 43	1F2893--	23	2A1927--	46, 47, 48
L626----	45, 46	1A3011--	37, 38	1B8704--	45, 46, 55	1F2894--	23	2A1936--	46, 47, 48, 49
L654----	20, 21	1A3452--	6, 7, 22	1B8706--	35, 36, 37, 54	1F2896--	23	2A2054--	57
L702----	14	1A4672--	14, 22, 23	1B8707--	23, 24	1F2913--	38, 39	2A2097--	50
L765----	12	1A5518--	26	1B8709--	23, 24	1F2944--	50	2A2209--	50
L900----	29	1A5535--	6	1B8712--	9, 10, 11, 14, 23, 24	1F2979--	53	2A2218--	50
L905----	18, 19	1A5566--	37, 38	1B8719--	42	1F3129--	42, 43	2A3223--	12, 13
L906----	18, 19	1A5826--	39	1B8720--	14	1F3131--	24, 25	2A3258--	51, 52, 53
L907----	18	1A5919--	15, 16, 17, 19, 20, 21, 22	1B8726--	30, 31	1F3222--	22, 23	2A3307--	50
L912----	18, 19	1A6240--	54, 55	1B8730--	9, 10, 11	1F3254--	9, 10, 11	2A3311--	50
L935----	8	1A6813--	11	1B8733--	14	1F3255--	23	2A3327--	50
S1012----	37, 38	1A6828--	51, 52, 53, 54	1B8735--	57	1F3257--	43	2A3328--	50
S1570----	58	1A6864--	37, 38	1B8743--	39	1F3275--	43	2A3338--	16, 17
S1571----	12	1A744--	35, 36, 37	1B8825--	7	1F3276--	43	2A3348--	50
S1574----	18, 19	1A7776--	51, 52, 53	1B914--	12	1F3286--	42, 43	2A3349--	50
S1580----	8, 51, 52, 53, 54	1A7784--	35, 36, 37	1B9757--	57	1F3293--	43	2A3398--	14
S1582----	7, 8	1A8178--	6	1B9704--	35, 36, 37	1F3294--	43	2A3447--	35, 36, 37
S1585----	12, 13, 15, 16, 17, 18, 19, 22	1A8191--	6	1B9982--	55	1F3298--	22, 23	2A3448--	35, 36
S1588----	12, 13, 14, 19, 22, 23, 26, 29, 35, 36, 37, 39, 40, 41, 49	1A8285--	54	1C155--	30, 31	1F3302--	23	2A3630--	37, 38, 39
S1589----	18, 19	1A8409--	9, 10, 11	1C157--	14	1F3321--	23	2A3665--	50
S1590----	6, 7, 27, 28, 45, 52, 53, 54	1A8412--	9, 10, 11	1C2251--	18, 27, 28, 53, 54, 55	1F3323--	25	2A3686--	50
S1591----	9, 10, 11, 15, 16, 17, 26, 27, 28, 48	1A8420--	12	1D4327--	30, 31	1F3324--	25	2A37--	9, 10, 11, 42
S1593----	28	1A8634--	50, 51, 52, 53	1D4539--	42, 44	1F3325--	25	2A3710--	18, 19
S1594----	6, 7, 9, 10, 11, 14, 15, 16, 17, 18, 19, 22, 28, 37, 42, 50, 54	1A9109--	55, 57	1D4717--	19, 54	1F3326--	25	2A3746--	14
S1595----	6, 7, 12, 13, 54	1B1897--	59	1D4901--	5	1F3335--	25	2A38--	9, 10, 11, 42
S1615----	55, 57	1B2402--	22, 23	1F1231--	14	1F3369--	36, 38	2A3856--	50
S1616----	57	1B2718--	29	1F1232--	14	1F3374--	21	2A3882--	50
S1617----	50, 57	1B2719--	57	1F1273--	9, 10, 11	1F3460--	50	2A3884--	46, 47
S1618----	40, 41, 42, 44, 55	1B2790--	42, 43, 55	1F1283--	34	1F3504--	56	2A3885--	46, 47, 48
S1621----	30, 31	1B4108--	5	1F1365--	5	1F3505--	56	2A389--	50
S1748----	28	1B4111--	5	1F1514--	22, 23	1F3506--	56	2A3893--	51, 52, 53, 54
S2388----	6, 7, 22	1B4201--	12, 57, 58	1F1515--	22, 23	1F3507--	56	2A3923--	22
S509----	22	1B4202--	29, 50, 54, 55	1F1538--	21, 32	1F3508--	56	2A3927--	15, 16, 17
S519----	19, 20, 21	1B4203--	6, 7, 8, 9, 10, 11, 12, 13, 19, 22, 23, 24, 26, 28, 35, 36, 37, 44, 45, 47, 48, 51, 52, 53, 54	1F1543--	21, 32	1F3509--	56	2A3928--	15, 16, 17, 47, 48
T284----	50	1B4204--	35, 36, 37	1F1544--	21, 32	1F3510--	56	2A3960--	21
T349----	35, 36, 37	1B4205--	5, 6, 7, 12, 13, 30, 31, 35, 36, 37	1F1546--	21, 32	1F3511--	56	2A3961--	21
		1B4330--	29	1F1547--	21, 32	1F3512--	56	2A3962--	21
		1B4418--	26	1F1577--	49	1F3513--	56	2A3971--	30, 31
				1F1569--	53, 54	1F3514--	56	2A3973--	5
				1F1584--	21, 32	1F3515--	56	2A3974--	5
				1F1585--	21, 32	1F3539--	40, 41, 42, 43	2A3977--	32
				1F1586--	32	1F3542--	29	2A3978--	30, 31
				1F1610--	16	1F3577--	5	2A3982--	15, 16, 17, 22
				1F1664--	48	1F3597--	50	2A3991--	5
				1F1733--	44	1F3659--	35, 36	2A3993--	5
				1F1739--	13	1F3755--	23, 24	2A3997--	53
				1F1740--	32	1F3756--	23, 24	2A4004--	30
				1F1741--	32	1F3784--	40, 41	2A4007--	8
						1F4372--	50	2A4008--	8
						1F4656--	58	2A4011--	53
						1F5192--	50		

CATERPILLAR D17000 DIESEL ENGINE

GEG-3861D

INDEX TO CATALOG NUMBERS (Cont'd)

Cat. No.	Page	Cat. No.	Page	Cat. No.	Page	Cat. No.	Page	Cat. No.	Page
2A4453--	27	2A5578--	50	2F1181--	58	3B4506--	5, 6, 7, 8, 9,	2A4013--	30, 31
2A4455--	55	2A5614--	50	2F1261--	55		11, 12, 13, 14,	2A4014--	30, 31
2A4462--	18, 19	2A5622--	9, 10, 11	2F1262--	55		19, 22, 23, 24,	2A4015--	39
2A4465--	18, 19	2A5710--	50	2F1263--	55		25, 27, 28, 37,	2A4016--	39
2A4473--	35, 36, 37	2A5748--	40, 41, 50	2F2045--	56		42, 44, 46, 47,	2A4017--	39
2A4474--	37, 38	2A5778--	46, 47, 48	2F2055--	56		48, 50, 53, 54,	2A4018--	30, 31
2A4488--	14	2A5779--	46, 47, 48	2F2058--	57		55	2A4019--	30, 31
2A4492--	37, 38, 39	2A5881--	49	2F2088--	27, 28	3B4508--	5, 6, 7, 12, 13,	2A4027--	27, 28
2A4494--	12	2A5890--	46, 47, 48	2F2316--	29		19, 22, 28, 30,	2A4028--	27, 28
2A4511--	50	2A5891--	46, 47, 48	2F2318--	29		31, 36, 37, 54	2A4031--	14
2A4522--	15, 16, 17	2A5902--	26	2F2326--	19	3B4605--	55	2A4046--	14
2A4523--	8	2A5904--	26	2F2369--	34	3B4607--	18, 19, 54, 55,	2A4052--	14
2A4524--	8, 37	2A5933--	42, 43	2F2370--	34		57	2A4069--	30, 31
2A4565--	12	2A614--	6, 7, 58	2F2869--	57	3B4608--	45, 46	2A4110--	14
2A4566--	12	2A6285--	42	2F2870--	57	3B4609--	35, 36, 37	2A4115--	35, 36
2A4569--	12	2A666--	29	2F2872--	49	3B4611--	14	2A4119--	35, 36
2A4572--	6, 7, 8	2A762--	15, 16, 17, 50	2F2934--	46, 47, 48	3B4615--	12	2A4121--	35, 36
2A4578--	5	2A763--	14	2F2953--	49	3B4617--	13	2A4139--	6, 7
2A4582--	5	2A849--	14	2F2989--	50, 53, 54	3B4618--	23, 24, 34	2A4153--	55
2A4620--	19, 20, 21	2A913--	51, 52, 53	2F2990--	53, 54	3B4619--	5	2A4157--	50
2A4621--	14	2B1170--	29	2F3043--	49	3B4621--	20	2A4158--	19
2A4638--	55	2B1397--	51, 52, 53, 54	2F3044--	58	3B4622--	19, 21	2A4159--	50
2A4639--	18, 19, 55	2B1560--	55	2F3096--	53, 54	3B4628--	35, 36, 37	2A4165--	55
2A4665--	55	2B1561--	55	2F3365--	55	3B4951--	55	2A4169--	55
2A4707--	18	2B1562--	55	2F4272--	25	3B5406--	36	2A4170--	55
2A4708--	50	2B1565--	55	2F4567--	12	3B5420--	18, 19	2A4171--	12
2A4709--	18, 19	2B1597--	54, 55	2F4615--	49	3B5656--	51, 52	2A4172--	55
2A4710--	50	2B1786--	35, 36, 37	2F5133--	58	3B5692--	55	2A4173--	12
2A4711--	50	2B2404--	52, 53, 54	2F5134--	58	3B622--	35, 36, 37, 38	2A4179--	14
2A4713--	50	2B2414--	21, 32	2F5272--	58	3B623--	38, 39	2A4181--	14
2A4716--	50	2B2694--	45, 46	2F534--	58	3B6368--	21, 32	2A4186--	19, 20, 21
2A4717--	50	2B2695--	26, 28, 55, 57	2F537--	58	3B645--	12	2A4189--	19, 20, 21
2A4718--	10	2B2994--	19, 20, 21	2F538--	58	3B6494--	40, 41	2A4191--	37, 38, 39
2A4733--	50	2B3705--	37, 38	2F541--	58	3B6734--	23, 24	2A4203--	22
2A4734--	50	2B3708--	37, 38	2F542--	58	3B6912--	18, 19, 22,	2A4213--	6
2A4779--	50	2B3712--	18	2F544--	58		28, 42	2A4217--	14
2A4781--	50	2B4011--	34	2F5788--	53, 54	3B7302--	37	2A4218--	14
2A4805--	51, 52, 53	2B4602--	5, 43	2F647--	6, 7	3B7583--	9, 10	2A4223--	14
2A4817--	50	2B4705--	31	2F652--	46, 47, 48	3B7606--	10	2A4224--	14
2A4818--	50	2B4823--	5	2F653--	46, 47	3B7733--	40, 41	2A4225--	14
2A4905--	50	2B5721--	6	2F654--	47, 48	3B8485--	5	2A4237--	14
2A4918--	10	2B5721--	26	2F656--	47	3B8489--	19, 54	2A4239--	55
2A4965--	18, 19	2B5803--	6, 26	2F6997--	46, 47	3B8612--	51, 52	2A4242--	50
2A4996--	7	2B6040--	9, 10, 11, 14	2F7054--	49	3B8764--	39	2A4248--	14
2A5029--	50	2B6461--	18	2F740--	50	3B8893--	39	2A4253--	19, 20, 21
2A5048--	50	2B6463--	18, 19	2F7410--	46	3B8894--	39	2A4254--	21
2A5064--	51, 52, 53, 54	2B7109--	35, 36, 37	2F7603--	34	3B8984--	40, 41	2A4255--	14
2A5065--	51, 52, 53, 54	2B7111--	35, 36, 37	2F8518--	7, 13	3B8991--	27, 57	2A4256--	14
2A5103--	51, 52	2B7113--	35, 36, 37	2F8616--	49	3B8993--	27, 28, 51, 52,	2A4257--	14
2A5104--	51, 52	2B7114--	35, 36, 37	2F873--	53, 54		53, 54	2A4258--	19, 20, 21
2A5112--	50	2B7115--	35, 36, 37	2F971--	27, 28	3B8995--	6, 7, 27, 28,	2A4259--	14
2A5128--	27	2B7408--	7, 22, 40, 41,	2F973--	27, 28		51, 52	2A4260--	50
2A5129--	27		51, 52	208-A--	55	3B8996--	49, 56	2A4261--	50
2A5130--	27	2B7409--	14, 23, 24, 36,	21889--	31	3B8998--	19, 27, 28, 51,	2A4262--	5
2A5132--	27		37, 40, 41, 45,	2580-A--	34		52, 53, 54, 57	2A4264--	19, 20, 21
2A5133--	27		57	2651-A--	19, 20, 21,	3B8999--	53, 54, 56, 57	2A4265--	19, 20, 21
2A5134--	27	2B7410--	6, 7, 29, 47, 48,		46, 47, 48	3B9000--	51, 52, 53, 54,	2A4270--	35, 36, 37
2A5138--	27		50, 58	2837-A--	56, 57		57	2A4274--	30, 31
2A5139--	27	2B7411--	7, 28	287409--	35	3B9001--	28, 51, 52, 53,	2A4286--	9, 10
2A5140--	27	2B7556--	50, 53, 54	2986-A--	5		54	2A4287--	9, 10, 11, 19
2A5141--	27	2B7557--	22	3B1142--	35, 36, 37	3B9003--	27, 28	2A4291--	10
2A5142--	27	2B7559--	15, 16, 17	3B1143--	35, 36, 37	3B9259--	32	2A4292--	9, 10, 11
2A5156--	27	2B7560--	15, 16, 17, 22	3B1304--	45, 46	3B9388--	47, 48, 51, 52,	2A4310--	9, 10, 11
2A5220--	50	2B7767--	30, 31	3B1915--	45, 46, 58		53, 54	2A4344--	51, 52, 53
2A5222--	50	2B7863--	12, 13	3B2743--	6, 7	3B9983--	45, 46	2A4354--	6, 7
2A5257--	40	2B7868--	12, 13	3B2939--	18, 19, 22	3F1414--	23	2A4355--	6, 7
2A5266--	40	2B8293--	37, 38	3B2940--	18, 19	3F1670--	50	2A4356--	6
2A5272--	40, 41	2B8593--	57	3B3459--	5	3F2128--	31	2A4379--	50
2A5273--	40, 41, 42, 43	2B8704--	51, 52, 53	3B4427--	35, 36, 37, 38	3F2671--	13	2A4382--	50
2A5277--	40, 41, 42, 43	2B8705--	51, 52, 53	3B4428--	35, 36, 37	3F4136--	59	2A4390--	35, 36, 37
2A5279--	40, 41	2F1010--	53, 54	3B4429--	35, 36, 37	3F4456--	53, 54	2A4395--	35, 36, 37
2A5281--	40, 41, 42, 43	2F1037--	27, 28	3B4430--	35, 36, 37	3F4463--	53, 54	2A4396--	37
2A5285--	40, 41, 43	2F1048--	27	3B4431--	35, 36, 37	3F5014--	50	2A4414--	35, 36, 37
2A53--	9, 10, 11, 42	2F1075--	27, 28	3B4432--	35, 36, 37	3F7445--	36, 37	2A4415--	35, 36, 37
2A5320--	40	2F1089--	27, 28	3B4433--	35, 36, 37	3F7577--	34	2A4416--	35, 36, 37
2A5349--	22, 23	2F1143--	51, 52, 53, 54	3B4434--	35, 36, 37	3F7862--	58	2A4424--	50
2A5351--	50	2F1146--	53, 54	3B4499--	6	3F8448--	57	2A4425--	10
2A5384--	50	2F1147--	53, 54	3B4501--	53, 54	3F8526--	36, 37	2A4425--	10
2A5386--	50	2F1148--	53, 54	3B4504--	14, 50, 54, 57	3F898--	34	2A4445--	18, 19
2A5387--	50	2F1149--	53, 54	3B4505--	28, 29, 42, 43,	3269-A--	18, 19	2A4446--	18, 19
2A5554--	40, 41, 42, 43	2F1153--	53, 54		44, 46, 50, 55,	3322-A--	30, 31	2A4448--	6, 7, 8, 15, 16,
2A5561--	40, 41, 42, 43	2F1154--	53, 54		57	4A141--	57		17, 35, 36, 37,
									48

CATERPILLAR D17000 DIESEL ENGINE

INDEX TO CATALOG NUMBERS (Cont'd)

Cat. No.	Page	Cat. No.	Page	Cat. No.	Page	Cat. No.	Page	Cat. No.	Page
4B1220--	51, 52, 53, 54	5B1638--	26	5B956---	55	6B3785--	56	6F2690--	11
4B1227--	22, 23	5B1661--	26, 28	5B9596--	40	6B4011--	34	6F2691--	11
4B1242--	18, 19	5B17----	15, 16, 17, 19, 20	5B9621--	49	6B4203--	23	6F2693--	11
4B1253--	14			5B9622--	49	6B4553--	22	6F2694--	11
4B1327--	12	5B1756--	20, 21, 26	5B9623--	49	6B4637--	30	6F2695--	11
4B1368--	55	5B1866--	22, 23	5B9724--	57	6B4681--	30, 31	6F2696--	11
4B1387--	55	5B1921--	28	5B9858--	22	6B4688--	30	6F2698--	11
4B1596--	12	5B2256--	28	5B9934--	40, 41	6B4689--	30, 31	6F2796--	11
4B1921--	18, 19, 22	5B2270--	28	5B9935--	40	6B4691--	30	6F2919--	11
4B2043--	51, 52, 53, 54	5B2271--	28	5B9966--	46, 47, 48	6B4693--	30, 31	6F3003--	11
4B2090--	14	5B2383--	35	5F1853--	34	6B4733--	57	6F3032--	33
4B2128--	55	5B2455--	22, 44	5F2407--	11	6B4738--	30, 31	6F3193--	7
4B2176--	40, 41	5B2468--	22	5F2422--	11	6B4790--	8	6F3196--	7
4B2199--	40, 41	5B2574--	6, 7	5F286---	31, 33	6B4796--	8	6F3202--	7, 28
4B2202--	40, 41	5B2579--	23, 24	5F287---	31, 33	6B4810--	8	6F3203--	7
4B2224--	40, 41	5B2593--	22	5F288---	31, 33	6B4874--	27, 28	6F3205--	7
4B2853--	12	5B2594--	22	5F289---	31, 33	6B5009--	14	6F3206--	7
4B2854--	12	5B2681--	34	5F334---	17, 21	6B5010--	14	6F3208--	7
4B2861--	55	5B2686--	26	5F360---	33	6B5925--	57	6F3218--	7
4B2870--	6, 7	5B2766--	12	5F361---	33	6B6131--	57	6F3450--	28
4B3191--	55	5B2839--	10, 11	5F362---	33	6B6132--	57	6F3581--	48
4B3672--	54	5B2968--	12	5F363---	33	6B6133--	57	6F3598--	36
4B413---	46, 47, 48, 51, 52, 53, 54	5B3029--	26	5F367---	32	6B6158--	51	6F3682--	24
		5B3185--	26	5F368---	32	6B6222--	39	6F3683--	24
4B4159--	59	5B3190--	20, 21	5F443---	33	6B6224--	37	6F3684--	24
4B418---	47, 48, 51, 52, 53, 54	5B3255--	6	5F444---	33	6B6225--	37	6F3685--	24
		5B3256--	6	5F6245--	13	6B635---	22	6F3687--	25
4B4283--	5	5B368---	35, 36, 37, 38	5F6710--	13	6B6489--	7	6F3689--	25
4B4298--	23	5B3718--	35, 36, 37	5F6752--	13	6B6705--	42, 43	6F3788--	28
4B479---	22, 23, 26	5B3729--	18, 19, 22, 28	5F8024--	9, 11	6B6861--	55	6F3808--	7
4B4948--	37	5B3850--	49	5F8025--	9, 11	6B6863--	31	6F385---	42, 43
4B5098--	45, 46	5B3865--	11	5F8026--	9, 11	6B690---	7	6F3893--	28
4B5270--	12, 13	5B4233--	23, 24	5F8027--	9	6B70---	18, 19	6F3958--	37
4B5315--	34	5B4683--	57, 58	5F8028--	11	6B7006--	54	6F4121--	28
4B5387--	23, 24	5B4690--	55	6B1156--	30	6B7020--	39	6F4193--	48
4B5883--	7	5B4691--	35, 36, 37, 55	6B1716--	57	6B7021--	39	6F4398--	42
4B611---	19	5B4693--	9, 10	6B1717--	57	6B7077--	54	6F4400--	42, 43
4B616---	19	5B4698--	10	6B1718--	57	6B7109--	35, 36, 37	6F4401--	42
4B6768--	18	5B54----	15	6B1719--	57	6B7120--	45, 52, 53, 54	6F4404--	42
4B8073--	55	5B5450--	34	6B1720--	57	6B7344--	58	6F4405--	42
4B8075--	55	5B5946--	26	6B1914--	40, 41, 42, 43	6B7861--	51, 52, 53, 54	6F4585--	42
4B8076--	55	5B5947--	26	6B1917--	10	6B7862--	51, 52, 53, 54	6F4587--	42
4B8079--	14	5B5971--	26	6B1919--	59	6B7863--	51, 52, 53, 54	6F4696--	13
4B8082--	55	5B5972--	26	6B2017--	45, 46	6B7864--	51, 52, 53, 54	6F4730--	24
4B8083--	14	5B5973--	26	6B2174--	34	6B7919--	22, 23	6F4731--	24
4B8438--	35	5B5974--	26	6B2255--	59	6B7962--	53	6F4733--	24
4B8537--	35, 36	5B5975--	26	6B2291--	34	6B8039--	42	6F4734--	24
4B8811--	46, 47, 48	5B5976--	26	6B2329--	35, 36, 37	6B8094--	42	6F4735--	24
4B9046--	45, 46	5B5977--	26	6B2846--	51, 52, 53	6B8241--	42, 43	6F4736--	24
4B9047--	45, 46	5B5978--	26	6B2955--	46, 47, 48	6B8242--	42, 43	6F4737--	24
4B9049--	45, 46	5B5982--	26	6B2958--	46, 47	6B8505--	35, 36, 37	6F4770--	42
4B9050--	45, 46	5B5983--	26	6B2983--	56	6B8630--	9, 10	6F4843--	19
4B9054--	45, 46	5B5984--	26	6B3003--	14	6B8675--	40, 41	6F4922--	36, 37
4B9056--	45, 46	5B6479--	22	6B3063--	46	6B8708--	52, 53	6F5138--	34
4B912---	44	5B6587--	23	6B3108--	6, 7	6B8798--	46, 47, 48	6F5257--	39
4B9121--	45	5B6904--	40, 41, 42, 43	6B3182--	8	6B8825--	22	6F5264--	34
4B9233--	51, 52, 53	5B6905--	40, 41, 42, 43	6B3133--	8	6B8826--	22	6F5301--	28
4B9406--	6, 7	5B7149--	23	6B3258--	23	6B8921--	22	6F5993--	37
4B9656--	45	5B7150--	23	6B3303--	22	6B8922--	22	6F6113--	37
4B9687--	7	5B7165--	39	6B3304--	22, 23	6B8924--	22	6F6178--	39
4B9731--	7	5B721--	14	6B3314--	23	6B9058--	50	6F6180--	37
4B991---	51	5B7210--	26	6B3315--	23	6B9059--	51	6F6182--	37
4B992---	51	5B7211--	26	6B3324--	23, 24	6B9086--	45	6F6183--	37
4F1238--	14	5B7212--	26	6B3362--	49	6B9087--	45	6F7027--	54
4F2736--	26, 28	5B723--	55	6B3363--	49	6B9186--	45	6F7033--	12
4F2739--	45, 46, 47, 48	5B7267--	26	6B3364--	49	6B9223--	51, 52, 53, 54	6F8136--	7
4F5420--	39	5B7340--	24	6B3398--	50	6B9507--	45	6F8447--	37
4F7059--	6	5B7589--	27	6B3400--	24	6B9596--	55	6F9223--	53
4F7816--	30, 31	5B7652--	21	6B3404--	8	6F1280--	5	6F9446--	37
4F8127--	42, 43	5B767---	34	6B3425--	23	6F1821--	24	6F9447--	21
4F846---	47	5B775---	55	6B3438--	51	6F1822--	24	6F9467--	7
4F8482--	43	5B8075--	50	6B3439--	51, 52, 53	6F2030--	31, 33	6F9545--	7
4F9262--	31	5B8607--	44, 49	6B3440--	51, 52, 53	6F2031--	31, 33	6F9880--	28
4F9433--	11	5B8609--	46, 47, 48, 49	6B3445--	46	6F2032--	31	6F9902--	7
4F9535--	11	5B8721--	26	6B3464--	23	6F2033--	31, 33	7B1167--	45
4F9785--	28	5B9079--	49	6B3505--	22	6F2034--	33	7B1168--	52, 53
4F9865--	34	5B9419--	26	6B3513--	23	6F2035--	33	7B124--	22, 23
4F9866--	34	5B9475--	57	6B3514--	23	6F2036--	33	7B1361--	23
497-A---	50	5B9476--	57, 58	6B3592--	23	6F2037--	33	7B1362--	23, 24
5B1082--	18, 19	5B9504--	45, 46	6B3641--	51, 52, 53	6F2038--	33	7B1363--	23
5B1344--	57	5B9506--	23, 24	6B3642--	51, 52, 53	6F2039--	33	7B1553--	5, 31
5B1345--	57	5B9508--	49	6B3699--	22	6F2301--	11	7B1554--	5

CATERPILLAR D17000 DIESEL ENGINE

GEG-3861D

INDEX TO CATALOG NUMBERS (Cont'd)

Cat. No.	Page	Cat. No.	Page	Cat. No.	Page	Cat. No.	Page	Cat. No.	Page
7B158---	58	7B3950--	15, 16, 17	7B7328--	52, 53, 54	8B24----	45, 46	8F4664--	48
7B1730--	54	7B3951--	15, 16, 17	7B7438--	47	8B2521--	57	8F8521--	21
7B1756--	35, 36, 37	7B3952--	15, 16, 17	7B7439--	47	8B3221--	54	8F8523--	21
7B1820--	38	7B4033--	26	7B7769--	13	8B3222--	54	8F9271--	34
7B1844--	39	7B4117--	50	7B7840--	49	8B3223--	52, 53, 54	9B1140--	5
7B195---	24	7B4216--	16, 17	7B7921--	49	8B3224--	52, 53, 54	9B1151--	53
7B197---	24	7B4289--	44	7B8017--	46, 47, 48	8B3225--	54	9B1161--	54
7B198---	24	7B4309--	18, 19	7B8072--	49	8B3226--	54	9B1332--	50
7B2094--	45, 46	7B4310--	6, 7	7B8201--	49	8B3227--	54	9B1691--	12
7B2125--	23, 24	7B4357--	19	7B8260--	46, 47, 48	8B3228--	54	9B2232--	40, 41, 43
7B2126--	13, 18, 19	7B4429--	18, 19	7B8285--	49	8B344---	49	9B2317--	41
7B2184--	22, 23	7B4508--	15, 16	7B8307--	52	8B3597--	58	9B2318--	41
7B2261--	52, 53	7B4515--	58	7B8355--	54	8B375---	18, 19	9B2320--	41
7B2335--	46, 47, 48	7B4991--	29	7B8357--	54	8B3802--	6, 7	9B2321--	41
7B244---	35	7B5265--	6, 7	7B8397--	47, 48	8B4132--	54	9B2453--	5
7B248---	22, 23	7B5281--	10, 11	7B8416--	47, 48	8B4735--	47, 48	9B3129--	28
7B253---	22, 23	7B537---	31	7B8433--	15, 16, 17	8B4967--	50	9B3305--	7
7B254---	22, 23	7B5391--	13	7B8512--	55	8B4990--	50	9B3306--	7
7B255---	22	7B5415--	37	7B8517--	49	8B5633--	57	9B3346--	30, 31
7B2573--	43	7B5459--	44	7B8563--	49	8B5937--	54	9B3425--	59
7B2579--	43	7B557---	13	7B8633--	49	8B652---	54	9B3620--	5
7B261---	22, 23	7B558---	13	7B8661--	49	8B6828--	21, 22, 23	9B3621--	5
7B264---	22	7B5586--	44	7B8767--	52, 53	8B703---	54	9B3622--	5
7B280---	35, 36, 37	7B559---	13	7B9002--	43	8B7378--	53	9B3623--	5
7B2940--	29	7B560---	13	7B9106--	49	8B7379--	53	9B3624--	5
7B3033--	30	7B5703--	18, 19	7B9159--	16, 17	8B8619--	13	9B4085--	50
7B3034--	31	7B5742--	44	7B9241--	35, 36	8B8906--	35, 36	9B4086--	50
7B305---	44, 45	7B6122--	49	7B9826--	57	8B8917--	45, 49, 53, 54	9B8681--	13
7B3130--	23	7B6325--	30, 31	7B9919--	58	8B8983--	12	9B8686--	13
7B3131--	23	7B6326--	15, 16, 17	7F3498--	19	8B9727--	7	9B8692--	13
7B3190--	19	7B6365--	49	7F3901--	48	8B9728--	7	9B8714--	29
7B3244--	15, 16, 17	7B6368--	49	7F4163--	7	8B9740--	22, 23	9B8720--	12
7B3254--	35, 37, 38	7B6768--	15	7F4863--	44	8B9828--	6, 7	9B8786--	13
7B3542--	17	7B6787--	34	7F4948--	19	8F2133--	43	9B8806--	12, 13
7B3559--	15, 16, 17	7B7071--	6, 7	7F8783--	39	8F3634--	46	9B8816--	12
7B3560--	19	7B7072--	6, 7	8B1402--	50	8F4292--	43	9B8820--	12
7B3719--	6, 7	7B7087--	5	8B1615--	23	8F4294--	44	9B8831--	12
7B3784--	6, 7	7B7088--	5	8B1675--	15, 16	8F4296--	44	9F2755--	21
7B3829--	19	7B7129--	49	8B2278--	19	8F4581--	43	9025----	20, 21
7B3839--	6, 7	7B7140--	54	8B2283--	27, 28				

LOCOMOTIVE AND CAR EQUIPMENT DEPARTMENT

GENERAL  **ELECTRIC**

ERIE, PA.

GENERAL  ELECTRIC

PYLE-NATIONAL TYPE C-620-GN HEADLIGHT

Manufactured by The Pyle-National Company
Chicago, Illinois

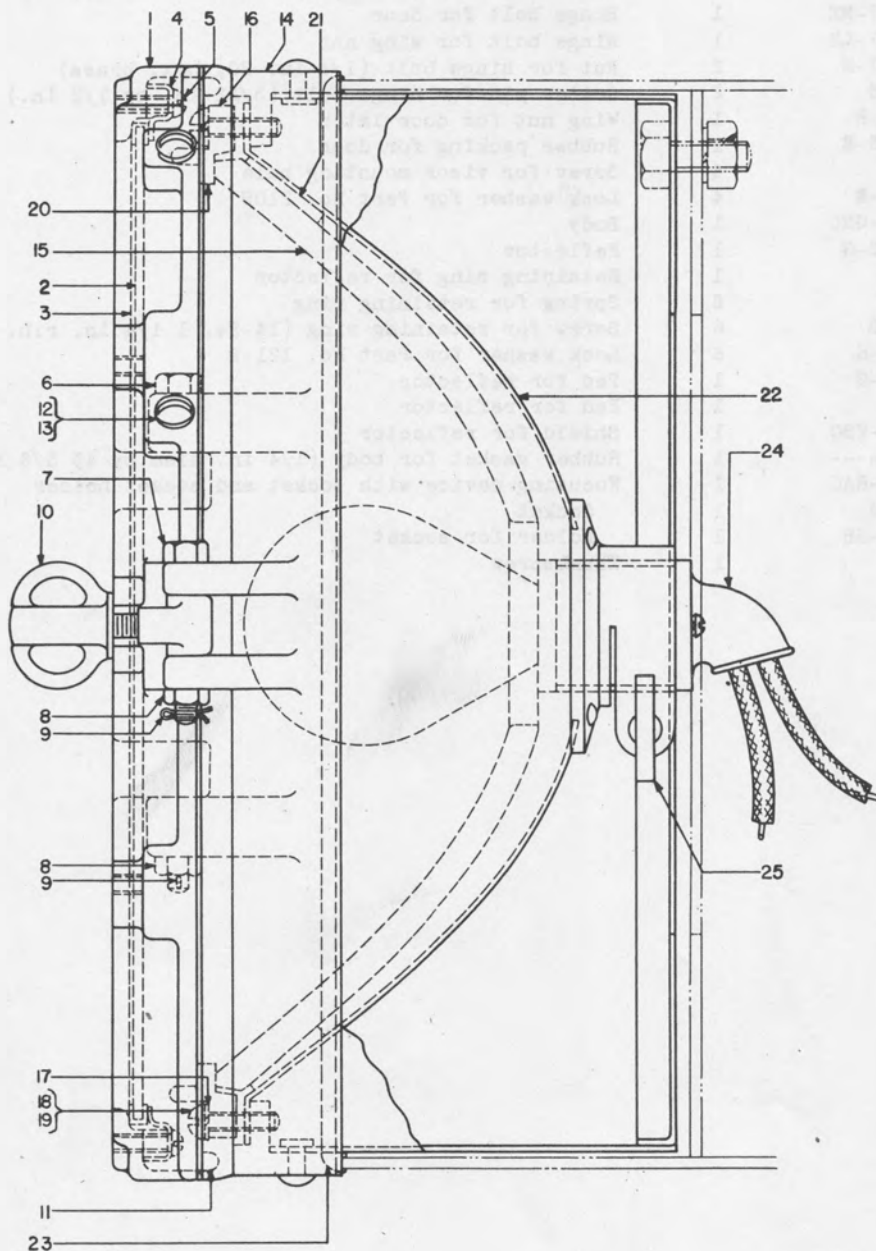

EXTRACT FROM THE PYLE-NATIONAL COMPANY'S PARTS LIST

GENERAL ELECTRIC

GEG-3870A

PYLE-NATIONAL TYPE C-620-GN HEADLIGHT

Ref. No.	Part No.	No. Re-quired	Description
1	1217-VR	1	Door
2	12042	1	Lens for door
3	6010	1	Gasket for lens
4	14118-D	6	Retaining clip for lens
5	1961	6	Screw for clip (14-24, 5/8 in. r.h. brass)
6	14017-MZ	1	Hinge bolt for door
7	14017-LZ	1	Hinge bolt for wing nut
8	14017-N	2	Nut for hinge bolt (1/4 in.-20, hex. brass)
9	COT-6	2	Cotter pin for hinge bolt (3/32 in. by 1/2 in.)
10	1843-R	1	Wing nut for door latch
11	RGS-5-E	1	Rubber packing for door
12	2109	4	Screw for visor mounting hole
13	1847-E	4	Lock washer for Part No. 2109
14	1201-GNC	1	Body
15	12012-G	1	Reflector
16	6003	1	Retaining ring for reflector
17	2619	6	Spring for retaining ring
18	121-B	6	Screw for retaining ring (14-24, 1 1/4 in. r.h. brass)
19	1847-E	6	Lock washer for Part No. 121-B
20	6012-G	1	Pad for reflector
21	6013	1	Pad for reflector
22	1224-VSC	1	Shield for reflector
23	-----	1	Rubber gasket for body (1/4 in. diam by 43 5/8 in. long)
24	1850-WAC	1	Focusing device with socket and socket holder
	LSH-5	1	Socket
	2019-SB	1	Holder for socket
25	557	1	Thumbscrew

THE UNITED STATES METALLIC PACKING COMPANY, PHILADELPHIA, PENNSYLVANIA.

KING OPERATING VALVE N°14

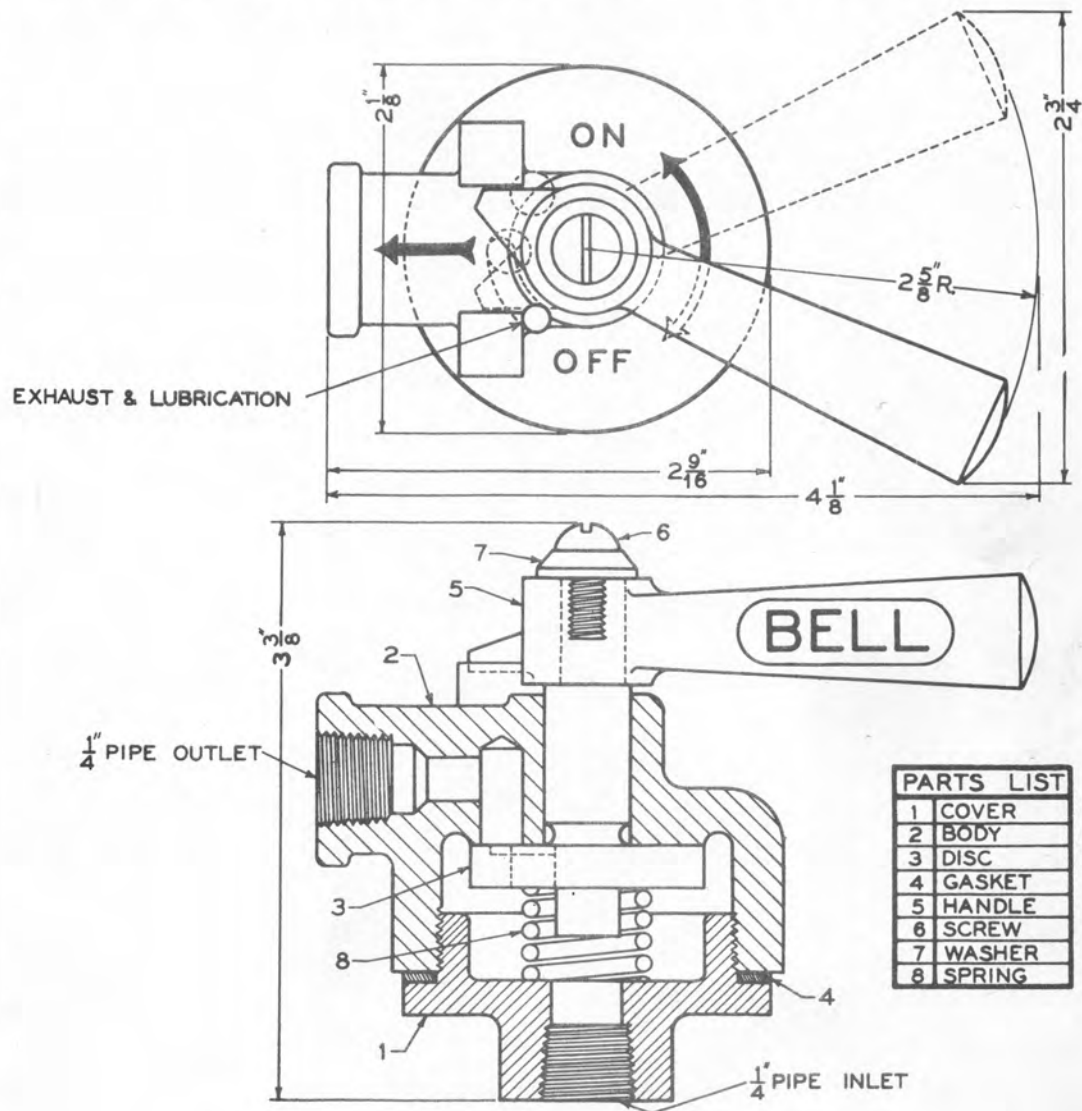

KING OPERATING VALVE N°14 IS IDEAL FOR BELL RINGER OPERATION; WHEN THE HANDLE OF THIS VALVE IS TURNED TO OFF POSITION, THE PRESSURE IN THE PIPE BETWEEN THE VALVE AND THE BELL RINGER EXHAUSTS TO THE ATMOSPHERE AND BELL STOPS RINGING.

THE UNITED STATES METALLIC PACKING COMPANY, PHILADELPHIA, PENNSYLVANIA.

KING OPERATING VALVE No 29

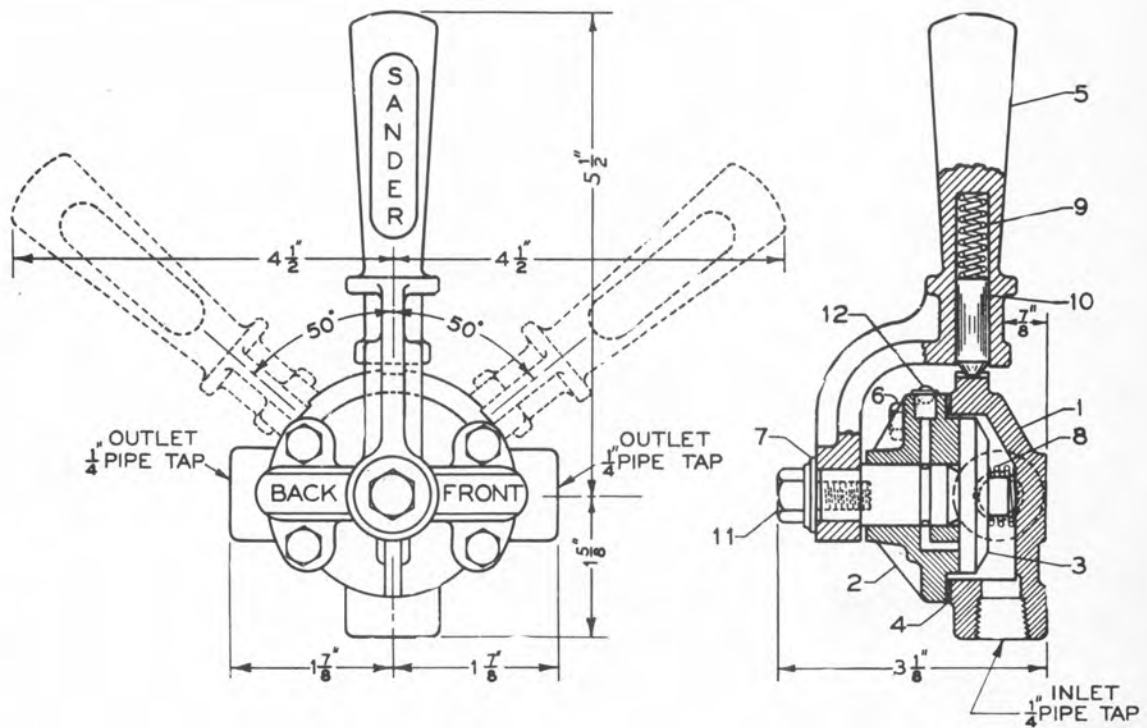

PARTS LIST

1	COVER	7	WASHER
2	BODY	8	VALVE SPRING
3	DISC	9	INDEX SPRING
4	GASKET	10	INDEX PLUNGER
5	HANDLE	11	HANDLE SCREW
6	BODY SCREW	12	OILER

KING OPERATING VALVE No 29 IS A DUPLEX VALVE HAVING ONE INLET AND TWO OUTLETS. IT IS USED PRINCIPALLY TO OPERATE FRONT AND BACK PNEUMATIC TRACK SANDERS. THIS VALVE REQUIRES NO PACKING AND THE FLAT SEAT WILL REMAIN TIGHT OVER A LONG PERIOD.



RENEWAL PARTS

GEG-3885C
Supersedes GEG-3885B

406-C ENGINE HEATER

Manufactured by
Perfection Stove Company, Inc.
Cleveland, Ohio

*Perfection Industries Inc
7609 Platt Ave
Cleveland 4, Ohio*

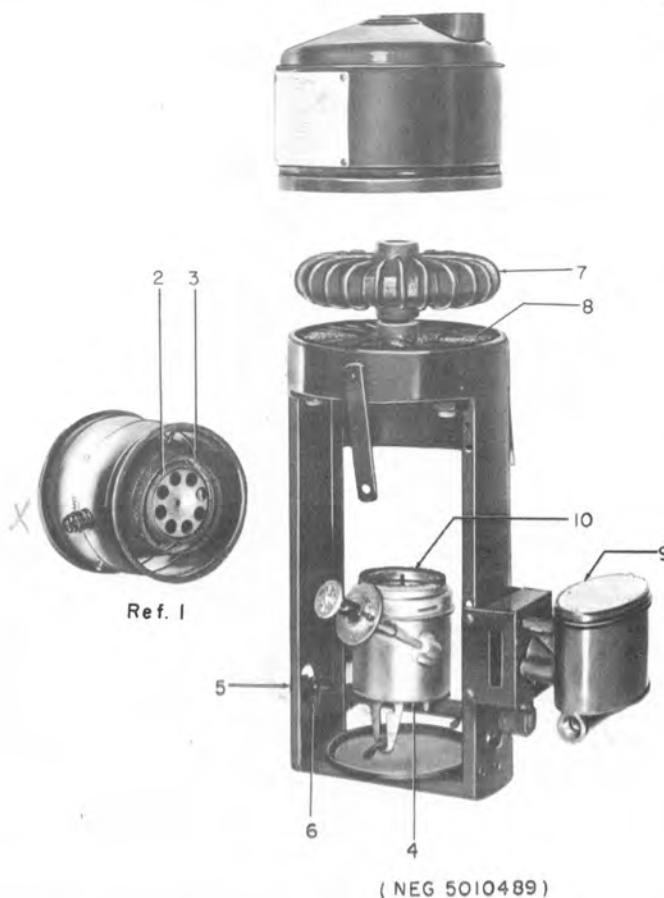

Ref. No.	New Part No.	Old Part No.	Description
1	A-12306	592X1	Burner drum, complete ✓ 11/13/59 ordered 2,
2	V-10126	920	Inner combustion tube for burner drum
3	V-10112	926	Outer combustion tube for burner drum
4	A-12608G1	909	Puritan burner wick tube
5	A-3125G2	643A2	Feed pipe cap
6	V-9569-1	374	Feed pipe holder
	A-12602-1	4538	Unit assembled, complete with fittings
7	V-10077	4537	Upper unit
8	V-10076	4535	Lower unit
9	V-9770G1	455C1	Constant level valve
10	V-9635	331-X	Perfection wick

When ordering renewal parts, give quantity, catalog number, description of each item required, and complete nameplate reading.

GENERAL  ELECTRIC

9-56(300)

Data subject to change without notice.

PRINTED
IN
U.S.A.

RENEWAL PARTS

STANDARD AIR-PUSH WINDOW WIPER

Manufactured by
C. A. Sprague Devices, Michigan City, Indiana

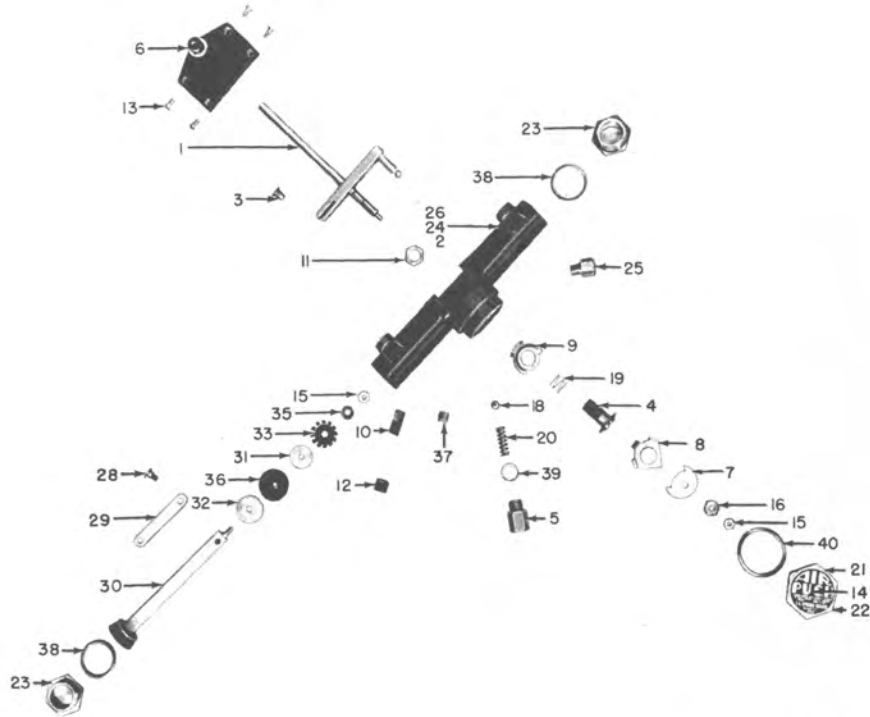

(PHOTO C-417)

DETAIL NO.	DESCRIPTION	PART NO.	NO. REQ.
1	Transmission arm	GCB	1
2	Wiper motor assembly	M-98	1
3	Transmission arm screw	C-521	1
4	Main bearing	C-402	1
5	Reverser ball housing	C-602	1
6	Outer bearing plate	C-210	1
7	Timer (specify angle)	C-750	1
8	Timer reverser	C-752	1

NOTE: Standard repair kit can be furnished if desired.

When ordering renewal parts, give quantity, catalog number, description of each item required, and complete nameplate reading.

GENERAL  ELECTRIC

STANDARD AIR-PUSH WINDOW WIPER

DETAIL NO.	DESCRIPTION	PART NO.	NO. REQ.
9	Timer valve	C-753	1
10	Exhaust nut felt washer	C-253	1
11	Bearing nut	C-524	2
12	Exhaust nut 1/4" compression	C-525	1
13	No. 6-32 flat hd. x 3/8"	C-523	4
14	No. 2-56 rd. hd. x 1/8"	C-522	1
15	Timer lock nut 10-32 hex	C-526	1
16	Timer nut	C-751	1
18	Reverser ball	C-401	1
19	Valve spring	C-303	1
20	Reverser ball spring	C-304	1
21	Nameplate	C-900	1
22	Air chamber cap	C-1000	1
23	Cylinder end cap	C-651	2
24	Motor body	Std. BWINS	1
25	Intake fitting	C-569	1
26	Exhaust fitting	C-570	1
28	Connecting link screw	C-520	1
29	Connecting link	C-352	1
30	Connecting rod	C-153	1
31	Piston inner plate	C-209	2
32	Piston outer plate	C-217	2
33	Piston spreader plate	C-305	2
35	No. 10 flat washer	C-519	2
36	Piston cup	C-254	2
37	1/8" pipe plug	C-701	1
38	Cylinder end cap gasket	C-453	2
39	Reverser ball gasket	C-451	1
40	Air chamber gasket	C-452	1
	Wiper arm assembly, regular (state length)	D-203-1	1
	1/4" x 20 hex nut	195-13H	1
	1/4 x 20 sq. hd. set screw x 3/4"	202-13SQ-3/4	1
	Wiper arm bearing pin	C-556	1
	Wiper arm assembly, adjustable (state length)	GC8	1
	Wiper blade, heavy duty (state length)	C-1100	1

LOCOMOTIVE AND CAR EQUIPMENT DEPARTMENT

GENERAL  **ELECTRIC**

ERIE, PA.

RENEWAL PARTS



CAB HEATERS

KYSOR MODEL VCRB

Cat. No. 8826963AA (14 Volt Service)
Cat. No. 8826963AN (37½ Volt Service)

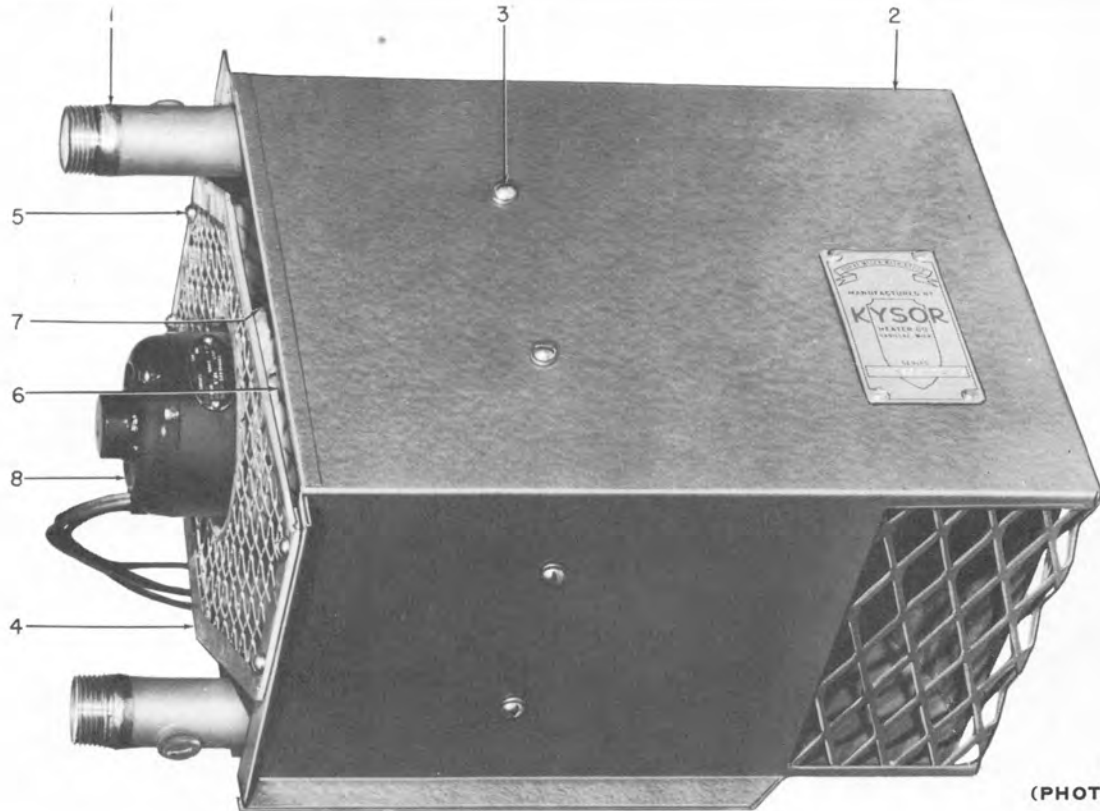

(PHOTO 5016931)

Ref. No.	No. Req'd. for Catalog No.		†Vendor's Cat. No.	Description
	8826963AA	8826963AN		
1	1	1	C3173-1	Core and tank assembly with connections
2	1	1	D3172	Jacket assembly with screen
3	1	1	C1270-1	Fan shroud casting
	8	8	-----	Bolt for shroud and jacket, 1/4 in. -20, 3/8 in., rd. hd.
4	8	8	-----	Lock washer, 1/4 in.
	1	1	B2238-1	Fan
	1	1	B1276	Guard for fan
5	4	4	-----	Screw for guard and jacket, 10-24, 3/8 in., rd. hd.
	4	4	-----	Lock washer, No. 10

† Kysor Heater Company.

When ordering renewal parts, give quantity, catalog number, description of each item required, and complete nameplate reading.



CAB HEATERS

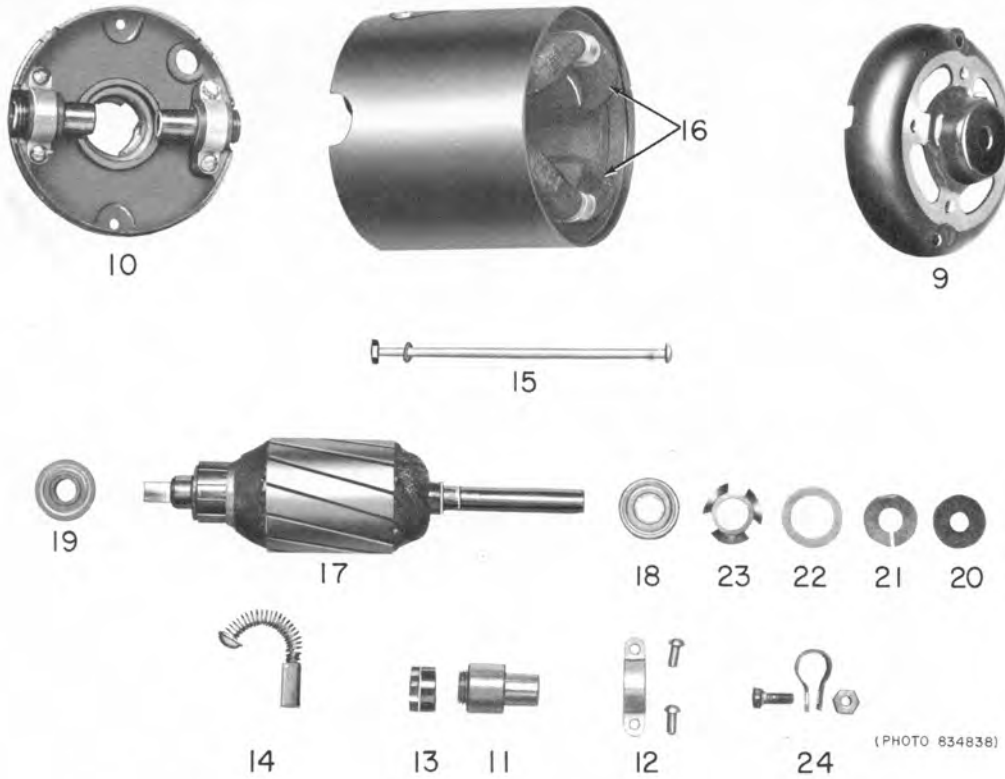

(PHOTO 834838)

Ref. no. 8, electric motor for heater

Ref. No.	No. Req'd. for Catalog No.		†Vendor's Cat. No.	Description
	8826963AA	8826963AN		
6	1	1	B2389	Motor mounting bracket casting
7	2	2	-----	Bolt for bracket and shroud, 5/16 in. -18, 3/4 in., hex. hd.
	2	2	-----	Lock washer, 5/16 in.
8	1	1	B1801	Motor mounting band
	2	2	-----	Bolt for band and bracket, 1/4 in. -20, 1 in., rd. hd.
9	2	2	-----	Lock washer, 1/4 in.
	1	1	B1767	Rubber mounting ring for motor
8	1	-	C3860	Electric motor, G-E Model 5BN56LA15 (14 volt service)
8	-	1	C5328	Electric motor, G-E Model 5BN56LA21 (37 1/2 volt service)
9	1	-	B3863	End shield, pulley end
9	-	1	B9722	End shield, pulley end
10	1	-	B3362	End shield with brush holders, opposite pulley end
10	-	1	B9716	End shield with brush holders, opposite pulley end
11	2	2	B3307	Brush holder with insulator
12	2	2	B3308	Strap with screws, for brush holder
13	2	2	B3306	Cap for carbon brush
14	2	-	B3292	Carbon brush
14	-	2	B9711	Carbon brush
15	2	-	B3364	Thru bolt with nut, for end shields
15	-	2	B9710	Thru bolt with nut, for end shields
16	1	-	B3379	Set of field coils
16	-	1	B9708	Set of field coils
17	1	-	B3363	Armature
17	-	1	B9709	Armature
18	1	1	B3365	Ball bearing, pulley end
19	1	-	B3325	Ball bearing, opposite pulley end

† Kysor Heater Company.

CAB HEATERS

GEG-3971D

Ref. No.	No. Req'd. for Catalog No.		†Vendor's Cat. No.	Description
	8826963AA	8826963AN		
19	-	1	B9715	Ball bearing, opposite pulley end
	-	2	B9717	Bearing sleeve, either end
20	1	-	B3326	Felt washer for end shield, pulley end
20	-	1	B9721	Felt washer for end shield, pulley end
21	1	-	B3327	Retainer for felt washer, pulley end
21	-	1	B9720	Retainer for felt washer, pulley end
22	2	-	B3328	Spacing washer, pulley end
22	-	2	B9719	Spacing washer, pulley end
23	1	-	B3329	Spring washer for ball bearing, pulley end
23	-	1	B9718	Spring washer for ball bearing, pulley end
24	2	2	B3305	Connection clip with screw and nut

† Kysor Heater Company.

WHEN YOU NEED SERVICE

IF YOU NEED TO REPAIR, recondition, or rebuild any electric apparatus, a G-E service shop near you is available day and night, seven days a week, for work in the shops or on your premises. Latest factory methods and genuine G-E renewal parts are used to maintain the original performance of your G-E equipment. For full information about these services, contact the nearest service shop or sales office listed below:

APPARATUS SERVICE SHOPS

*Denotes Aircraft Service Shops

Albany, N. Y. 1097 Central Ave.
Allentown, Pa. 668 E. Highland St.
Appleton, Wis. Midway Industrial Area
County Trunk, "P" P.O. Box 83
Atlanta—Chamblee, Ga. 4639 Peachtree
Indus. Blvd.
*Arkansas City, Kan. P.O. Box 526
Baltimore 30, Md. 920 E. Fort Ave.
Boston—Medford 55, Mass. 3960 Mystic
Valley Pkwy.
Buffalo 11, N. Y. 318 Urban St.
Charleston 28, W. Va. 306 MacCorkle Ave., S.E.
Charlotte, N. C. 2328 Thrift Road
Chicago 32, Ill. 4360 W. 47th St.
Cincinnati 2, Ohio 444 W. Third St.
*Cincinnati 3, Ohio 956 E. Court St.
Cleveland 4, Ohio 4966 Woodland Ave.
Columbus 23, Ohio 2128 Eakin Rd.
Corpus Christi, Texas 115 Busse St.
*Dallas, Texas 1135-1215 S. Lamar St.
Dallas 19, Texas 3202 Manor Way
Davenport—Bettendorf, Ia. 1039 State St.
Decatur, Ill. 2225 E. Logan St.
Denver 5, Colo. 3353 Larimer St.
Detroit 2, Mich. 5950 Third Ave.
Ft. Wayne, Ind. 606 W. Superior St.
Houston 20, Texas 5534 Harvey Wilson Drive
Indianapolis 22, Ind. 1740 W. Vermont St.
Johnstown, Pa. 841 Oak St.
Kansas City 20, Mo. 3525 Gardner Ave.
Los Angeles 1, Calif. 6900 Stanford Ave.
Louisville, Ky. 2014 New Main St.
Midland, Tex. 3404 Bankhead Hwy.
Milwaukee 3, Wis. 940 W. St. Paul Ave.
Minneapolis 12, Minn. 2025 49th Ave., N.
New Orleans, La. 2815 N. Robertson St.
New York—N. Bergen, N. J. 6001 Tonnelle St.
Oakland, Calif. 1525 Peralta St.
*Ontario, Calif. Ont. Int'l Airport
Philadelphia 24, Pa. 1040 E. Erie Ave.
Pittsburgh 6, Pa. 6519 Penn Ave.
Portland 10, Oregon 2727 N.W. 29th Ave.
Richmond 24, Va. 1403 Ingram Ave.
Roanoke, Va. 115 Albermarle St.
Sacramento, Calif. 99 N. 17th St.
St. Louis 10, Mo. 1115 East Road
Salt Lake City 4, Utah 301 S. Seventh West St.
San Francisco 3, Calif. 1098 Harrison St.
Seattle 4, Wash. 3422 First Ave., S.
*Seattle 4, Wash. 3422 First Ave., S.
Southington, Conn. 53 Railroad Ave.
Spokane 3, Wash. S. 155 Sherman St.
Tampa 1, Fla. P.O. Box 1245,
Naval Indus. Res. Shipyard
Toledo 4, Ohio 1 So. St. Clair St.
Wheeling, W. Va. 2050 National Rd.
York, Pa. 54 N. Harrison St.
Youngstown 7, Ohio 272 E. Indianola Ave.

APPARATUS SALES OFFICES

Abilene, Texas 442 Cedar St.
Akron 8, Ohio 335 S. Main St.
Albany 3, N. Y. 8 Colvin Ave.
Albuquerque, N. Mex. 323 Third St., S.W.
Alexandria, La. 720 Murray St.
Allentown, Pa. 1132 Hamilton St.
Amarillo, Texas Amarillo Bldg.
Appleton, Wis. 510 W. College Ave.
Atlanta 3, Ga. P.O. Box 4659
1860 Peachtree Rd., N.W.
Augusta, Ga. Masonic Bldg.
Augusta, Me. 152 State St.
Baltimore 1, Md. 111 Park Ave.
Bangor, Maine P.O. Box 778, 77 Central St.
Baton Rouge 6, La. 3170 Florida Blvd.
Battle Creek, Mich. 25 W. Michigan Ave.
Beaumont, Texas P.O. Box 2870
1385 Calder Ave.
Billings, Mont. Rm. 816, 303 No. Broadway
Binghamton, N. Y. P.O. Box 931
19 Chenango St.

Birmingham 3, Ala. P.O. Box 2602
1804 Seventh Ave., N.
Bismarck, N. Dak. 418 Rosser Ave.
Bluefield, W. Va. P.O. Box 447, 704 Bland St.
Appalachian Bldg.
Boise, Idaho 1524 Idaho St.
Boston 1, Mass. 140 Federal St.
Buffalo 2, N. Y. 625 Delaware Ave.
Butte, Mont. P.O. Box 836, 103 N. Wyoming St.
Canton 2, Ohio 700 Tuscarawas St., W.
Cedar Rapids, Iowa 210 Second St., S.E.
Charleston 28, W. Va. P.O. Box 2313
306 MacCorkle Ave., S.E.
Charlotte 1, N. C. P.O. Box 1969
112 S. Tryon St.
Chattanooga 2, Tenn. 832 Georgia Ave.
Chicago 80, Ill. P.O. Box 5970A, 840 S. Canal St.
Cincinnati 2, Ohio 2621 Victory Pkwy.
Cleveland 4, Ohio 4966 Woodland Ave.
Columbia 1, S.C., P.O. Box 1434, 1420 Lady St.
Columbus 15, Ohio 40 S. Third St.
Corpus Christi, Texas 205 N. Chaparral
Dallas 2, Texas 1801 N. Lamar St.
Davenport—Bettendorf, Ia. P.O. Box 630
1039 State St.
Dayton 2, Ohio 11 W. Monument Bldg.
Dayton 9, Ohio Avia. & Def.,
2600 Far Hills Ave.
Denver 2, Colo. P.O. Box 2331
650 Seventeenth St.
Des Moines 9, Iowa 505 W. Fifth Ave.
Detroit 2, Mich. 700 Antoinette St.
Duluth 2, Minn. 14 W. Superior St.
Elmira, N. Y. P.O. Box 971
Main and Woodlawn Aves.
El Paso, Texas 215 No. Stanton
Erie 2, Pa. 1001 State St.
Eugene, Ore. 1170 Pearl St.
Evansville 19, Ind. P.O. Box 157
123 N.W. Fourth St.
Fairmont, W. Va. P.O. Box 1626
310 Jacobs Bldg.
Fergus Falls, Minn. P.O. Box 197
108 N. Court Ave.
Flint 3, Mich. 653 S. Saginaw St.
Fort Wayne 6, Ind. 3606 So. Calhoun St.
Fort Worth 2, Tex. 408 W. Seventh St.
Fort Worth, Tex. P.O. Box 9218, Avia. & Def.,
6200 Camp Bowie Blvd.
Fresno 1, Calif. 407 Patterson Bldg.
Tulare and Fulton St.
Grand Rapids 2, Mich. 425 Cherry St., S.E.
Greensboro, N. C. P.O. Box 1162
301 S. Elm St.
Greenville, S. C. P.O. Box 1408
108 W. Washington St.
Gulfport, Miss. 207 Jo-Fran Bldg.
Hagerstown, Md. P.O. Box 477
Professional Arts Bldg.
Hartford 5, Conn. 764 Asylum St.
Houston 1, Texas 1312 Live Oak St.
Indianapolis 4, Ind. 110 N. Illinois St.
Jackson, Mich. 120 W. Michigan Ave.
Jackson 1, Miss. 203 W. Capitol St.
Jacksonville 2, Fla. Station G—Box 48
700 E. Union St.
Johnstown, Pa. 841 Oak St.
Joplin, Mo. P.O. Box 948, 220 1/2 W. Fourth St.
Kalamazoo 3, Mich. P.O. Box 447
114 Parkway Ave.
Kansas City 6, Mo. 106 W. Fourteenth St.
Knoxville 16, Tenn. 1301 Hannah Ave.
Lake Charles, La. P.O. Box 5212
422 Seventh St.
Lansing 8, Mich. 814 Michigan National Tower
Lexington, Ky. First National Bank Bldg.
Lincoln 8, Nebr. Sharpe Bldg., 206 S. 13th St.
Little Rock, Ark. 103 W. Capitol Ave.
Los Angeles 54, Calif. 212 N. Vignes St.
Louisville 2, Ky. 455 S. Fourth St.
Lubbock, Texas P.O. Box 1464
3302 Avenue "A"
Macon, Ga. P.O. Box 1506, 682 Cherry St.
Madison 3, Wis. 16 N. Carroll St.

Manchester, N. H. 875 Elm St.
Medford, Ore., P.O. Box 1349, 107 E. Main St.
Memphis 3, Tenn. 8 N. Third St.
Miami 32, Fla. P.O. Box 5062
25 S.E. Second Ave.
Midwest City, Okla. P.O. Box 5867
Avia. & Def., 207 Post Off. Bldg.
Milwaukee 3, Wis. 940 W. St. Paul Ave.
Minneapolis 3, Minn. 12 S. Sixth St.
Mobile Ala. 704 Government St.
Nashville 3, Tenn. 234 Third Ave., N.
Newark 2, N. J. 744 Broad St.
New Haven 6, Conn. 129 Church St.
New Orleans 12, La. 837 Gravier St.
New York 22, N. Y. 570 Lexington Ave.
New York Avia. & Def., Fed. Bldg.,
International Airport, Jamaica 30, N. Y.
Niagara Falls, N. Y. 44 Fall St.
Norfolk 10, Va. 229 W. Bute St.
Oakland 12, Calif. P.O. Box 1106
409 Thirteenth St.
Oklahoma City 2, Okla. 119 N. Robinson St.
Omaha 2, Nebr. 409 S. Seventeenth St.
Pasco, Wash. P.O. Box 971, 824 W. Lewis St.
Peoria 2, Ill. 309 Jefferson Bldg.
Philadelphia 2, Pa. 3 Penn Center Plaza
Phoenix, Ariz. P.O. Box 4037, 220 Luhrs Tower
Pittsburgh 22, Pa. The Oliver Bldg., Mellon Sq.
Portland 7, Ore. P.O. Box 909
920 S.W. Sixth Ave.
Providence 3, R. I. Industrial Trust Bldg.
Raleigh, N. C. P.O. Box 2507
16 W. Martin St.
Reading, Pa. 31 N. Sixth St.
Richmond 17, Va. P.O. Box 2188
700 E. Franklin St.
Riverside, Calif. 3570 Ninth St.
Roanoke 16, Va. P.O. Box 871
920 S. Jefferson St.
Rochester 4, N. Y. 89 E. Ave.
Rockford, Ill. 110 S. First St.
Rutland, Vt. 38 1/2 Center St.
Sacramento 14, Calif. 626 Forum Bldg.
Saginaw, Mich. Second National Bank Bldg.
St. Louis 1, Mo. 818 Olive St.
Salt Lake City 10, Utah P.O. Box 779
200 S. Main St.
San Antonio 5, Texas 434 So. Main Ave.
San Diego 1, Calif. P.O. Box 1222
1240 Seventh Ave.
San Francisco 6, Calif. 235 Montgomery St.
San Jose 10, Calif. 460 Park Ave.
Savannah, Ga. 40 East Bay St.
Seattle 4, Wash. P.O. Box 1858
710 Second Ave.
Seattle 8, Wash. Avia. & Def., 220 Dawson St.
Shreveport, La. 206 Beck Bldg.
Sioux City 13, Iowa 572 Orpheum Electric Bldg.
South Bend 1, Ind. 112 W. Jefferson Blvd.
Spokane 4, Wash. S. 162 Post St.
Springfield, Ill. 607 E. Adams St.
Springfield 3, Mass. 1387 Main St.
Stockton, Calif. 11 So. San Joaquin St.
Syracuse 6, N. Y. P.O. Box 1021
3532 James St.
Tacoma 1, Wash. P.O. Box 1485
1202 Washington Bldg.
Tampa 6, Fla. P.O. Box 3092, 1206 North A St.
Toledo 4, Ohio 420 Madison Ave.
Trenton 8, N. J. 214 E. Hanover St.
Tucson, Ariz. P.O. Box 710, 650 N. Sixth Ave.
Tulsa 3, Okla. 320 S. Boston Ave.
Utica 2, N. Y. 258 Genesee St.
Washington 5, D. C. 777-14th St., N.W.
Waterloo, Iowa 206 W. 4th St.
Wenatchee, Wash. P.O. Box 676
328 N. Wenatchee Ave.
Wheeling, W. Va. 40 Fourteenth St.
Wichita 2, Kan. 200 E. First St.
Williamston, N. C., P.O. Box 748, 115 E. Main St.
Worcester 5, Mass. 288 Grove St.
York, Pa. 56 N. Harrison St.
Youngstown 5, Ohio 272 E. Indianola Ave.

Hawaii: American Factors, Ltd., P. O. Box 3230, Honolulu 1 Canada: Canadian General Electric Company, Ltd., Toronto

LOCOMOTIVE AND CAR EQUIPMENT DEPARTMENT, GENERAL ELECTRIC COMPANY, ERIE, PA.

GENERAL ELECTRIC

TYPE B BRAKE CYLINDER (6 IN. BY 8 IN.)

Manufactured by
The New York Air Brake Company
New York, New York

and
Westinghouse Air Brake Company
Pittsburgh, Pa.

Ref. No.	N.Y.A.B. PC. No.	W.A.B. PC. No.	Description
	N-5390	519820	TYPE B, 6 IN. BY 8 IN. BRAKE CYLINDER

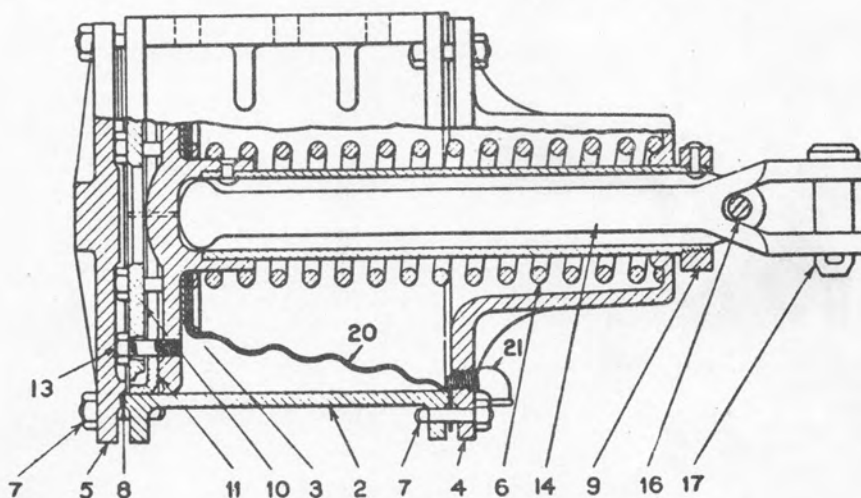

2	BC-1062	8613	Cylinder body
3	BC-3066	1235	Piston and rod (includes Ref.No. 13)
4	BC-20622-C	87959	Non-pressure head for cylinder with protector (includes Ref.No. 21)
4	BC-2064	1234	Non-pressure head for cylinder without protector
5	BC-2065	8614	Pressure head
6	BC-73	1239 -	Release spring
7	BC-819-A	4889	Bolt and nut for cylinder head (10 required)
8	BC-871	1243	Gasket for cylinder
9	BC-611	1019	Holder for push rod
10	BC-4061	1238 -	Follower for piston
11	BC-4066	68577	Pecking for piston
13	BC-880	27345	Stud and nut for follower (3 required)
14	BC-5156-C	9686	Push rod with pin (includes Ref.No. 17)
	QT-32	33310	Pipe plug (1/2 in.)
16	BC-639-C	7144	Push rod holder pin with cotter pin
17	BC-859-C	6616	Push rod pin with cotter pin
20	N-1847	87073 -	Protector
21	PF-98	84819	Street ell

RENEWAL PARTS



FIG. 1280A OIL FILTER

Wm. W. Nugent and Company, Inc.

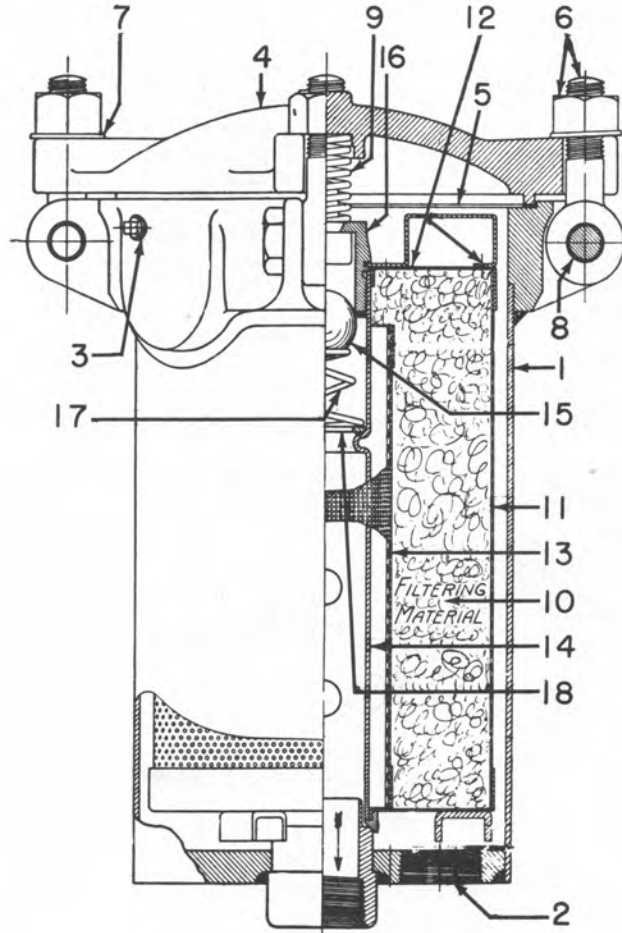

(NEG. A109490)

Ref. No.	No. Req'd. for Filter Size			†Vendor's Part No.	Description
	4L	4R	4S		
1	1	-	-	1280CV-4L	Shell for filter
1	-	1	-	1280CV-4R	Shell for filter
1	-	-	1	1280CV-4S	Shell for filter
2	1	1	1	1116BAC	Drain plug for shell, 1/2 in. I.P.S.

† Wm. W. Nugent and Company, Inc. Orders for parts should specify both size and serial number of filter.

When ordering renewal parts, give quantity, catalog number, description of each item required, and complete nameplate reading.

GENERAL ELECTRIC

FIG. 1280A OIL FILTER

Ref. No.	No. Req'd. for Filter Size			†Vendor's Part No.	Description
	4L	4R	4S		
3	1	1	1	1116ZB	Vent plug for shell, 1/4 in. I. P. S.
4	1	1	1	1116GO	Cover for filter
5	1	1	1	1116E	Gasket for cover
6	4	4	4	1116GZ	Eyebolt with nut, for cover
7	4	4	4	1116AV	Washer for nut
8	4	4	4	1116BAU	Hinge pin for eyebolt
9	1	1	1	1116FF	Shock spring (under cover)
10	1	-	-	1280F-4L	Repackable cotton recharge
10	-	1	-	1280F-4R	Repackable cotton recharge
10	-	-	1	1280F-4S	Repackable cotton recharge
11	1	-	-	1280C-4L	Cage for filtering unit
11	-	1	-	1280C-4R	Cage for filtering unit
11	-	-	1	1280C-4S	Cage for filtering unit
12	1	1	1	1280E	Cover for filtering cage
13	1	-	-	1280D-4L	Strainer tube
13	-	1	-	1280D-4R	Strainer tube
13	-	-	1	1280D-4S	Strainer tube
14	1	1	1	1280K	Center outlet tube
15	1	1	1	1116EB	Relief ball
16	1	1	1	1280H	Seat for relief ball
17	1	1	1	1280P	Relief spring
18	1	1	1	1280W	Washer for relief spring
	1	1	1	1280AY	∅ By-pass plug
	1	1	1	1280BT	"Throw-away" recharge

† Wm. W. Nugent and Company, Inc. Orders for parts should specify both size and serial number of filter.

∅ By-pass plug, Part No. 1280AY, is used in place of Ref. Nos. 15 to 18, incl., on filters NOT equipped with by-pass relief valves.

address → ~~470-412 North Hermitage Ave.~~
~~Chgo, Ill no good~~

M+J #1 Has Nugent Filter size 4L - No 1280A
 Serial no. F45F

LOCOMOTIVE AND CAR EQUIPMENT DEPARTMENT

GENERAL  ELECTRIC

ERIE, PA.

RENEWAL PARTS

SCREW SOCKET RECEPTACLE

Type Numbers

MRFA - 1

MRFHA - 1

Manufactured by Pyle-National Company
1334 North Kostner Avenue, Chicago 51, Illinois

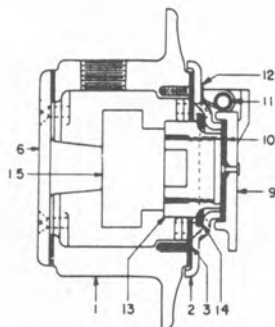
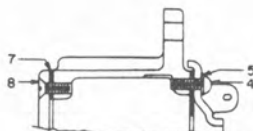

Ref. No.	No. Req. for Type		Cat.No.	Description
	MRFA-1	MRFHA-1		
1	1	1	MRF-1-A	Base (1/2 in.)
2	1		MR-14	Housing
2		1	MR-17	Housing
3	1		MR-4	Gasket between base and housing
3		1	MR-23	Gasket between base and housing
4	4	4	-----	Screw fastening housing to base (10-24, 5/8 in. round head, brass)
5	4	4	-----	Lock washer (No. 10)
6	1	1	MR-13	Back cover for base
7	1	1	MR-15	Gasket between back cover and base
8	4	4	-----	Screw fastening back cover to base (10-24, 9/16 in. flat head, brass)
9	1		MR-3	Front cover, for housing
9		1	MR-18	Front cover, for housing
10	1		MR-5	Gasket for cover
11	1	1	MR-7	Hinge pin for cover
12	1	1	MR-6	Spring for hinge pin and cover
13	1		MR-8	Insulation ring
14	1		MR-16	Gasket between insulation ring and housing
15	1		LCL-4-W	Receptacle for base
15		1	LCL-4	Receptacle for base

When ordering renewal parts, give quantity, catalog number, description of each item required, and complete nameplate reading.

GENERAL  ELECTRIC

WHEN YOU NEED SERVICE

IF YOU NEED TO REPAIR, recondition, or rebuild any electric apparatus, a G-E service shop near you is available day and night, seven days a week, for work in the shops or on your premises. Latest factory methods and genuine G-E renewal parts are used to maintain the original performance of your G-E equipment. For full information about these services, contact the nearest service shop or sales office listed below:

APPARATUS SERVICE SHOPS

Allentown, Pa. 668 E. Highland St.
 Appleton, Wisc. Midway Industrial Area,
 County Trunk, "P" P.O. Box 83
 Atlanta—Chamblee, Ga. 4639 Peachtree
 Indus. Blvd.
 Baltimore 30, Md. 920 E. Fort Ave.
 Boston—Medford 55, Mass. Mystic Valley Pkwy.
 Buffalo 11, N. Y. 318 Urban St.
 Charleston 28, W. Va. 306 MacCorkle Ave., S.E.
 Charlotte, N. C. 2328 Thrift Road
 Chicago 32, Ill. 4360 W. 47th St.
 Cincinnati 2, Ohio 444 W. Third St.
 Cleveland 4, Ohio 4966 Woodland Ave.
 Columbus 23, Ohio 2128 Eakin Rd.
 Corpus Christi, Texas 115 Busse St.
 Dallas 19, Texas 3202 Manor Way
 Davenport—Bettendorf, Ia. 1039 State St.
 Decatur, Ill. 2225 E. Logan St.
 Denver 5, Colo. 3353 Larimer St.
 Detroit 2, Mich. 5950 Third Ave.
 Houston 20, Texas. 5534 Harvey Wilson Drive
 Indianapolis 22, Ind. 1740 W. Vermont St.
 Johnstown, Pa. 841 Oak St.
 Kansas City 20, Mo. 3525 Gardner Ave.
 Los Angeles 1, Calif. 6900 Stanford Ave.
 Louisville, Ky. 2014 New Main St.
 Midland, Tex. 3404 Bankhead Hwy.
 Milwaukee 3, Wisc. 940 W. St. Paul Ave.
 Minneapolis 12, Minn. 2025 49th Ave., N.
 New Orleans, La. 2815 N. Robertson St.
 New York—N. Bergen, N.J. 6001 Tonnelie Ave.
 Oakland, Calif. 1525 Peralta St.
 Philadelphia 24, Pa. 1040 E. Erie Ave.
 Pittsburgh 6, Pa. 6519 Penn Ave.
 Portland 10, Oregon 2727 N.W. 29th Ave.
 Richmond 24, Va. 1403 Ingram Ave.
 Roanoke, Va. 115 Albermarle St.
 Sacramento, Calif. 99 N. 17th St.
 St. Louis 10, Mo. 1115 East Road
 Salt Lake City 4, Utah. 301 S. Seventh West St.
 San Francisco 3, Calif. 1098 Harrison St.
 Seattle 4, Wash. 3422 First Ave., S.
 Southington, Conn. 53 Railroad Ave.
 Spokane 3, Wash. S. 155 Sherman St.
 Tampa 1, Fla. P.O. Box 1245,
 Naval Indus. Res. Shipyard
 Toledo 4, Ohio. 1 So. St. Clair St.
 Wheeling, W. Va. 2050 National Rd.
 York, Pa. 54 N. Harrison St.
 Youngstown 7, Ohio 272 E. Indianola Ave.

APPARATUS SALES OFFICES

Abilene, Texas. 442 Cedar St.
 Akron 8, Ohio. 335 S. Main St.
 Albany 7, N. Y. 90 State St.
 Albuquerque, N. Mex. 323 Third St., S.W.
 Alexandria, La. 720 Murray St.
 Allentown, Pa. 1132 Hamilton St.
 Amarillo, Texas. Amarillo Bldg.
 Appleton, Wisc. 531 W. College Ave.
 Atlanta 3, Ga. P.O. Box 4659
 1860 Peachtree Rd., N.W.
 Augusta, Ga. Masonic Bldg.
 Augusta, Me. 152 State St.
 Baltimore 1, Md. 111 Park Ave.
 Bangor, Maine. P.O. Box 778, 77 Central St.
 Baton Rouge 6, La. 3170 Florida Blvd.
 Battle Creek, Mich. 25 W. Michigan Ave.
 Beaumont, Texas. P.O. Box 2870
 1385 Calder Ave.
 Billings, Mont. Rm. 816, 303 No. Broadway
 Binghamton, N. Y. P.O. Box 931
 19 Chenango St.
 Birmingham 3, Ala. P.O. Box 2602
 1804 Seventh Ave., N.
 Bismarck, N. Dak. 418 Rosser Ave.
 Bluefield, W. Va. P.O. Box 447, 704 Bland St.
 Appalachian Bldg.
 Boise, Idaho. 1524 Idaho St.

Boston 1, Mass. 140 Federal St.
 Buffalo 3, N. Y. 535 Washington St.
 Butte, Mont. P.O. Box 836, 103 N. Wyoming St.
 Canton 2, Ohio. 700 Tuscarawas St., W.
 Cedar Rapids, Iowa 210 Second St., S.E.
 Charleston 28, W. Va. P.O. Box 2313
 306 MacCorkle Ave., S.E.
 Charlotte 1, N. C. P.O. Box 1969
 112 S. Tryon St.
 Chattanooga 2, Tenn. 832 Georgia Ave.
 Chicago 80, Ill. P.O. Box 5970A, 840 S. Canal St.
 Cincinnati 2, Ohio 215 W. Third St.
 Cleveland 4, Ohio 4966 Woodland Ave.
 Columbia 1, S.C., P.O. Box 1434, 1420 Lady St.
 Columbus 15, Ohio 40 S. Third St.
 Corpus Christi, Texas 205 N. Chaparral
 Dallas 2, Texas. 1801 N. Lamar St.
 Davenport—Bettendorf, Ia. P.O. Box 630
 1039 State St.
 Dayton 2, Ohio 11 W. Monument Bldg.
 Dayton 9, Ohio. Avia. & Def.,
 2600 Far Hills Ave.
 Denver 2, Colo. P.O. Box 2331
 650 Seventeenth St.
 Des Moines 9, Iowa 505 W. Fifth Ave.
 Detroit 2, Mich. 700 Antoinette St.
 Duluth 2, Minn. 14 W. Superior St.
 Elmira, N. Y. P.O. Box 971
 Main and Woodlawn Aves.
 El Paso, Texas. 215 No. Stanton
 Erie, Pa. 1001 State St.
 Eugene, Ore. 1170 Pearl St.
 Evansville 19, Ind. P.O. Box 157
 123 N.W. Fourth St.
 Fairmont, W. Va. P.O. Box 1626
 310 Jacobs Bldg.
 Fergus Falls, Minn. P.O. Box 197
 108 N. Court Ave.
 Flint 3, Mich. 653 S. Saginaw St.
 Fort Wayne 6, Ind. 3606 So. Calhoun St.
 Fort Worth 2, Tex. 408 W. Seventh St.
 Fort Worth, Tex. P.O. Box 9218, Avia. & Def.,
 6200 Camp Bowie Blvd.
 Fresno 1, Calif. 407 Patterson Bldg.
 Tulare and Fulton St.
 Grand Rapids 2, Mich. 425 Cherry St., S.E.
 Greensboro, N. C. P.O. Box 1162
 301 S. Elm St.
 Greenville, S. C. P.O. Box 1408
 108 W. Washington St.
 Gulfport, Miss. 207 Jo-Fran Bldg.
 Hagerstown, Md. P.O. Box 477
 Professional Arts Bldg.
 Hartford 5, Conn. 764 Asylum Ave.
 Houston 1, Texas. 1312 Live Oak St.
 Indianapolis 4, Ind. 110 N. Illinois St.
 Jackson, Mich. 120 W. Michigan Ave.
 Jackson 1, Miss. 203 W. Capitol St.
 Jacksonville 2, Fla. Station G—Box 48
 700 E. Union St.
 Jamestown, N. Y. P.O. Box 548, 2 Second St.
 Johnstown, Pa. 841 Oak St.
 Joplin, Mo. P.O. Box 948, 220 1/2 W. Fourth St.
 Kalamazoo 3, Mich. P.O. Box 447
 114 Parkway Ave.
 Kansas City 6, Mo. 106 W. Fourteenth St.
 Knoxville 16, Tenn. 1301 Hannah Ave.
 Lake Charles, La. P.O. Box 5212
 422 Seventh St.
 Lansing 8, Mich. 306 Michigan National Tower
 Lexington, Ky. First National Bank Bldg.
 Lincoln 8, Nebr. Sharpe Bldg., 206 S. 13th St.
 Little Rock, Ark. 103 W. Capitol Ave.
 Los Angeles 54, Calif. 212 N. Vignes St.
 Louisville 2, Ky. 455 S. Fourth St.
 Lubbock, Texas. P.O. Box 1464
 3302 Avenue "A"
 Macon, Ga. P.O. Box 1506, 682 Cherry St.
 Madison 3, Wisc. 16 N. Carroll St.
 Manchester, N. H. 875 Elm St.
 Medford, Ore. P.O. Box 1349, 107 E. Main St.

Memphis 3, Tenn. 8 N. Third St.
 Miami 32, Fla. P.O. Box 5062
 25 S.E. Second Ave.
 Midwest City, Okla. P.O. Box 5867
 Avia. & Def., 207 Post Off. Bldg.
 Milwaukee 3, Wisc. 940 W. St. Paul Ave.
 Minneapolis 3, Minn. 12 S. Sixth St.
 Mobile 13, Ala. P.O. Box 973, 54 St. Joseph St.
 Nashville 3, Tenn. 234 Third Ave., N.
 Newark 2, N. J. 744 Broad St.
 New Haven 6, Conn. 129 Church St.
 New Orleans 12, La. 837 Gravier St.
 New York 22, N. Y. 570 Lexington Ave.
 Avia. & Def., Fed. Bldg.,
 International Airport, Jamaica 30, N. Y.
 Niagara Falls, N. Y. 253 Second St.
 Norfolk 10, Va. 229 W. Bute St.
 Oakland 12, Calif. P.O. Box 1106
 409 Thirteenth St.
 Oklahoma City 2, Okla. 119 N. Robinson St.
 Omaha 2, Nebr. 409 S. Seventeenth St.
 Pasco, Wash. P.O. Box 971, 824 W. Lewis St.
 Peoria 2, Ill. 309 Jefferson Bldg.
 Philadelphia 2, Pa. 3 Penn Center Plaza
 Phoenix, Ariz. P.O. Box 4037, 303 Luhrs Tower
 Pittsburgh 22, Pa. The Oliver Bldg., Mellon Sq.
 Portland 7, Ore. P.O. Box 909
 920 S.W. Sixth Ave.
 Providence 3, R. I. Industrial Trust Bldg.
 Raleigh, N. C. P.O. Box 2507
 16 W. Martin St.
 Reading, Pa. 31 N. Sixth St.
 Richmond 17, Va. P.O. Box 2188
 700 E. Franklin St.
 Riverside, Calif. 3570 Ninth St.
 Roanoke 16, Va. P.O. Box 871
 920 S. Jefferson St.
 Rochester 4, N. Y. 89 E. Ave.
 Rockford, Ill. 110 S. First St.
 Rutland, Vt. 38 1/2 Center St.
 Sacramento 14, Calif. 626 Forum Bldg.
 Saginaw, Mich. Second National Bank Bldg.
 St. Louis 1, Mo. 818 Olive St.
 Salt Lake City 10, Utah. P.O. Box 779
 200 S. Main St.
 San Antonio 5, Texas. 434 So. Main Ave.
 San Diego 1, Calif. P.O. Box 1222
 1240 Seventh Ave.
 San Francisco 6, Calif. 235 Montgomery St.
 San Jose 10, Calif. 460 Park Ave.
 Savannah, Ga. P.O. Box 682, 4 E. Bryan St.
 Seattle 4, Wash. P.O. Box 1858
 710 Second Ave.
 Seattle 8, Wash. Avia. & Def., 220 Dawson St.
 Shreveport, La. 206 Beck Bldg.
 Sioux City 13, Iowa. 572 Orpheum Electric Bldg.
 South Bend 1, Ind. 112 W. Jefferson Blvd.
 Spokane 4, Wash. S. 162 Post St.
 Springfield, Ill. 607 E. Adams St.
 Springfield 3, Mass. 1387 Main St.
 Stockton, Calif. 11 So. San Joaquin St.
 Syracuse 6, N. Y. P.O. Box 1021
 3532 James St.
 Tacoma 1, Wash. P.O. Box 1485
 1202 Washington Bldg.
 Tampa 6, Fla. P.O. Box 3092, 1206 North A St.
 Toledo 4, Ohio. 420 Madison Ave.
 Trenton 8, N. J. 214 E. Hanover St.
 Tucson, Ariz. P.O. Box 710, 650 N. Sixth Ave.
 Tulsa 3, Okla. 320 S. Boston Ave.
 Utica 2, N. Y. 258 Genesee St.
 Washington 5, D. C. 777-14th St., N.W.
 Waterloo, Iowa. 206 W. 4th St.
 Wenatchee, Wash. P.O. Box 676
 328 N. Wenatchee Ave.
 Wheeling, W. Va. 40 Fourteenth St.
 Wichita 2, Kan. 200 E. First St.
 Williamston, N. C., P.O. Box 748, 115 E. Main St.
 Worcester 5, Mass. 288 Grove St.
 York, Pa. 56 N. Harrison St.
 Youngstown 5, Ohio. 272 E. Indianola Ave.

Hawaii: American Factors, Ltd., P. O. Box 3230, Honolulu 1 Canada: Canadian General Electric Company, Ltd., Toronto

LOCOMOTIVE AND CAR EQUIPMENT DEPARTMENT, GENERAL ELECTRIC COMPANY, ERIE, PA.



INSTRUCTIONS

GEI-37789C

OPERATION AND MAINTENANCE AIR-COOLED AIR COMPRESSOR

TYPE ADS (ALL MODELS)

GARDNER-DENVER

Fig. 1. (A-125091)

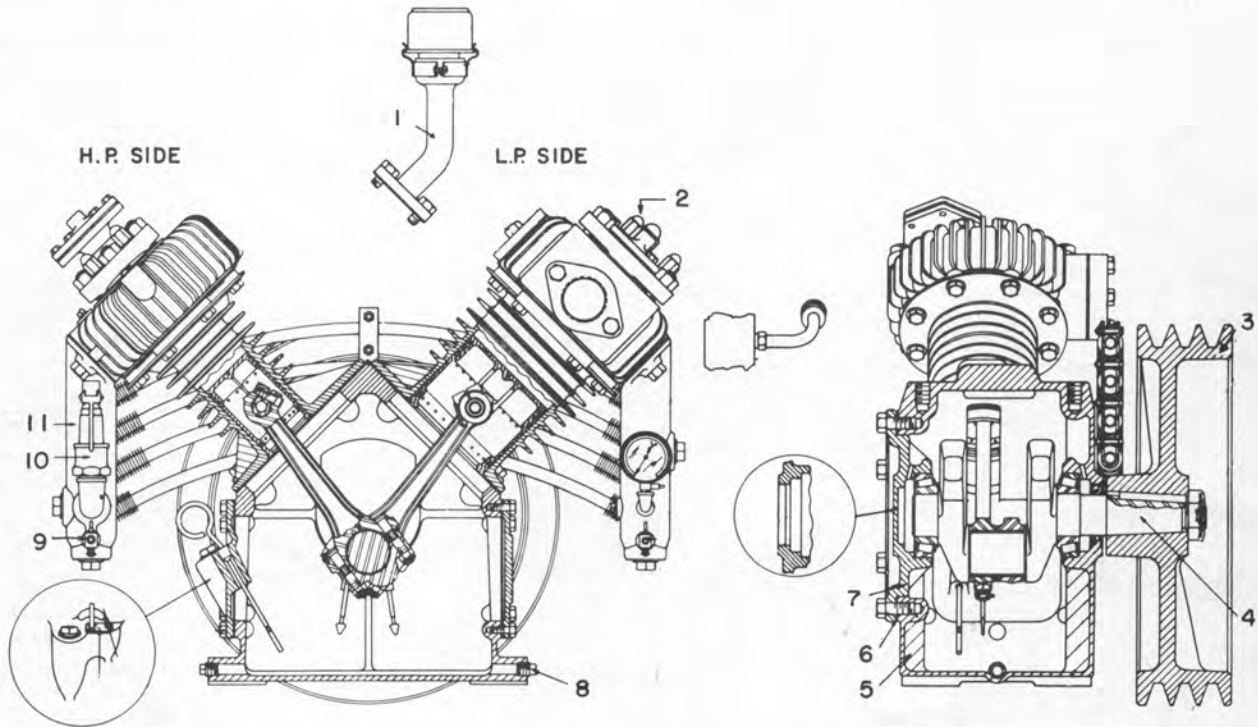

1 Oil filter
2 Clamp screw nut
3 Sheave

4 Crankshaft
5 Crankcase
6 Shims
7 Bearing end plate
8 Crankcase oil drain plug

9 Draincock
10 Safety valve
11 Inter-cooler header

Fig. 1. Sectional views of air compressor

INSPECTION AND LUBRICATION

Daily

1. Check oil level in crankcase and maintain between high and low marks on bayonet gage.
2. Operate safety valve by hand to make sure it functions.
3. Drain condensate from intercooler.

Every 200 Operating Hours

1. Remove intake filter and crankcase breather from compressor, wash in suitable solvent, dry, dip in clean crankcase oil, drain, and install on compressor.
2. Drain crankcase while oil is warm, flush with flushing oil (not kerosene or gasoline), clean with lint-free rags, and refill with new lubricant. See Table I. Crankcase capacity is 7 quarts.

These instructions do not purport to cover all details or variations in equipment nor to provide for every possible contingency to be met in connection with installation, operation or maintenance. Should further information be desired or should particular problems arise which are not covered sufficiently for the purchaser's purposes, the matter should be referred to the General Electric Company.

TABLE I
LUBE-OIL SPECIFICATIONS

Approximate "SAE" Number	Summer Temp. SAE-30 or SAE-40	Where 2-104B or MIL-0-2104 "Heavy-Duty Lubri- cants" are used, SAE-20 and SAE-40 are not avail- able, and in this case, use SAE-30 for summer and SAE-10 for winter.
	20 F Min. SAE-20	
	Below 20 F SAE-10W	
Viscosity Index	60 Minimum	
Pour Point	15 F Below Min. Starting Temp.	
Flash Point, Min. (For SAE-30 or 40)	400 F	SAE-10 or 20 may be slightly lower.
Fire Point, Min. (For SAE-30 or 40)	450 F	SAE-10 or 20 may be slightly lower.
Corrosion Resistance		The oil must be non-corrosive to copper-lead or steel backed babbitt-lined bearings at 230 F.
Carbon Residue, Max.	0.25%	
Ash Content, Mas.	0.004%	Many locomotive operators use the same oil for com- pressor and main diesel engine at least during mod- erate weather. Since most "Heavy-Duty Diesel- Engine Oils" are compounded with detergents and inhibitors, the ash content may safely run higher than shown due to the metallic soap in the additives.
Film Strength		Film strength should be enhanced by the addition of a moderate to extreme pressure additive to assist in preventing seizure between sliding or rotating metal parts.

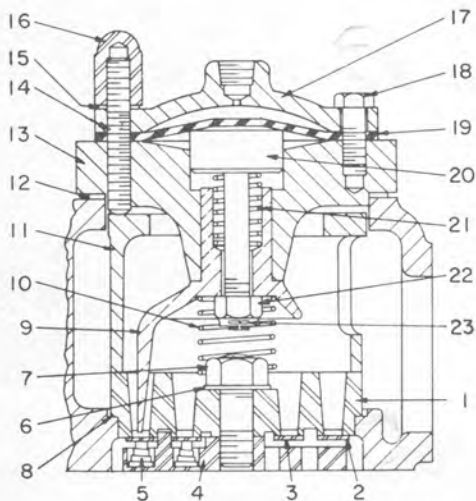

- | | |
|----------------------------------|----------------------------------|
| 1 Seat | 15 Valve clamp screw gasket |
| 2 Valve (outer) | 16 Valve clamp screw nut |
| 3 Valve (inner) | 17 Unloader diaphragm cap |
| 4 Valve bumper | 18 Unloader diaphragm cap screw |
| 5 Spring | 19 Unloader diaphragm |
| 6 Bumper washer | 20 Upper unloader plunger |
| 7 Bumper nut | 21 Upper unloader plunger spring |
| 8 Valve seat gasket | 22 Upper unloader nut |
| 9 Lower unloader plunger | 23 Upper unloader cotter pin |
| 10 Lower unloader plunger spring | |
| 11 Valve clamp | |
| 12 Valve cover plate gasket | |
| 13 Valve cover plate | |
| 14 Valve clamp screw | |

Fig. 2. L. P. suction unloading valve

Fig. 2 (E-1520)

Every Two Months

Check and maintain valves.

Every Three Months

1. Test compressor for capacity by orifice test. Repair compressor when capacity is less than 80 percent of a new or reconditioned compressor. See TESTING ON LOCOMOTIVE or TESTING ON BENCH.

2. Install test gage in intercooler. Normal pressure is 42 to 43 pounds at 140-pounds discharge pressure.

Annually

Test intercooler safety gage. Proper setting is 60 pounds.

In general a highly refined turbine quality oil, with or without additives, obtained from any reputable and reliable oil company will give satisfactory service in a compressor, exhaustor or expressor, provided oil is maintained between the high and low marks on oil-level gage, and the correct viscosity (or SAE number) and pour point are used as shown for various seasonal temperatures.

VALVES

Refer to Figs. 2-7.

1. Seat and bumper - remove carbon and dirt and replace damaged parts.

2. Valve disks - replace if warped, chipped, cracked, or excessively worn at point of contact with seat, valve springs or unloading finger.

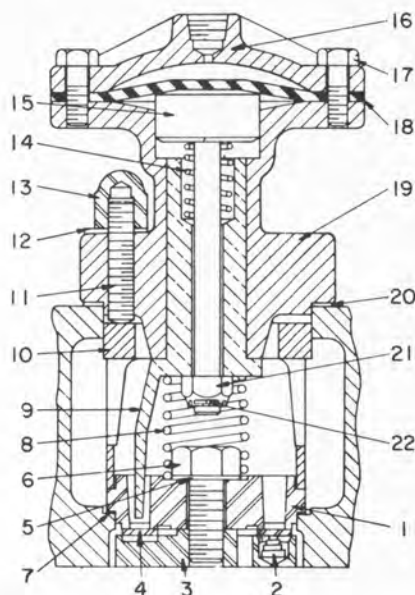

- | | |
|--------------------------|----------------------------------|
| 1 Seat | 15 Upper unloader plunger |
| 2 Spring | 16 Diaphragm cap |
| 3 Valve bumper | 17 Diaphragm cap screw |
| 4 Valve | 18 Unloader diaphragm |
| 5 Bumper washer | 19 Valve cover plate |
| 6 Bumper nut | 20 Valve cover plate gasket |
| 7 Seat gasket | 21 Upper unloader plunger nut |
| 8 Lower unloader spring | 22 Upper unloader plunger cotter |
| 9 Lower unloader plunger | |
| 10 Valve clamp | |
| 11 Valve clamp screw | |
| 12 Clamp screw gasket | |
| 13 Clamp screw nut | |
| 14 Upper unloader spring | |

Fig. 3. H. P. suction unloading valve

- | |
|------------------------|
| 1 Bumper |
| 2 Valve |
| 3 Valve seat with stud |
| 4 Valve spring |
| 5 Bumper washer |
| 6 Bumper nut |
| 7 Seat gasket |
| 8 Valve clamp |
| 9 Clamp screw |
| 10 Screw gasket |
| 11 Clamp nut |
| 12 Cover plate |
| 13 Plate gasket |

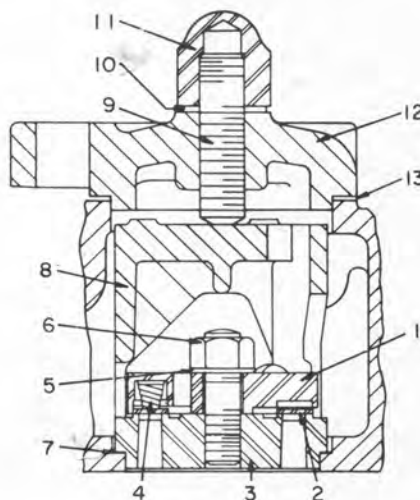
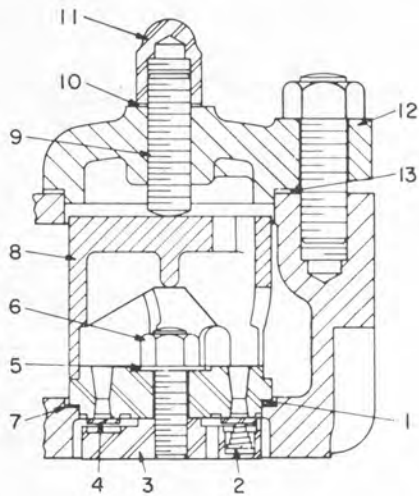

Fig. 4. H. P. discharge valve

Fig. 3 (E-1521)

Fig. 4 (E-6604)



- | | |
|--------------------|----------------------|
| 1 Valve assembly | 8 Valve clamp |
| 2 Seat | 9 Clamp screw |
| 3 Spring | 10 Clamp gasket |
| 4 Bumper with stud | 11 Clamp nut |
| 5 Valve | 12 Valve cover plate |
| 6 Bumper washer | 13 Plate gasket |
| 7 Bumper nut | |

Fig. 5. H. P. suction valve, plain

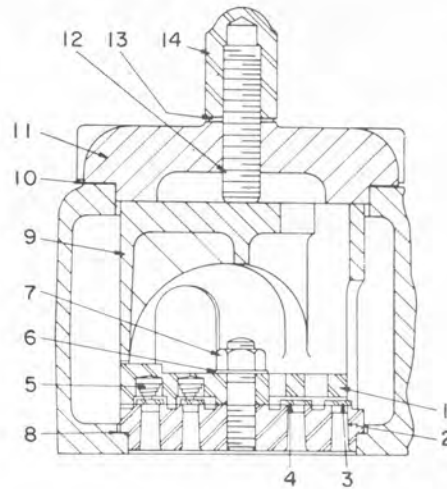

- | | |
|------------------------|-----------------|
| 1 Bumper | 8 Seat gasket |
| 2 Valve seat with stud | 9 Valve clamp |
| 3 Valve (outer) | 10 Plate gasket |
| 4 Valve (inner) | 11 Cover plate |
| 5 Spring | 12 Clamp screw |
| 6 Bumper washer | 13 Screw gasket |
| 7 Bumper nut | 14 Nut |

Fig. 7. L. P. discharge valve

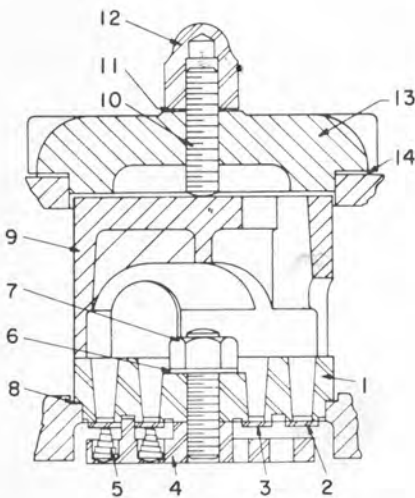

- | | |
|-------------------|---------------------|
| 1 Seat | 8 Valve seat gasket |
| 2 Valve (outer) | 9 Valve clamp |
| 3 Valve (inner) | 10 Clamp screw |
| 4 Bumper and stud | 11 Clamp packing |
| 5 Spring | 12 Clamp nut |
| 6 Stud washer | 13 Cover plate |
| 7 Nut | 14 Plate gasket |

Fig. 6. L. P. suction valve, plain

3. Valve springs - replace if rusted, or if springs have lost tension.

4. Diaphragm - replace if cracked.

Valve troubles are diagnosed with the compressor running and with an accurate gage installed in the intercooler as follows:

- a. If the intercooler pressure is abnormally high only when pumping, inspect the HP suction valve.
- b. If the intercooler pressure climbs slowly when unloaded, check the HP discharge valve or HP suction unloading mechanism.
- c. If the intercooler pressure is abnormally low when pumping and drops to zero pressure in less than 3 minutes when unloaded, inspect the LP discharge valves.
- d. If the intercooler pressure is abnormally low when pumping, but drops only a few pounds after being unloaded 3 minutes, inspect the LP suction valves.

The location of the specific LP discharge or LP suction valves at fault will usually be indicated by a weak or erratic suction sound, abnormal blowback from air filter, or an excessively hot LP discharge-valve cover plate.

Fig. 5 (E-6605)

Fig. 7 (E-6607)

Fig. 6 (E-6606)

Before removing a valve assembly, remove clamp screw nuts and back off clamp screws. Remove the cover and clamp and lift out the valve assembly.

If valves contain carbon, dismantle, soak in kerosene, and clean by scraping and brushing. Dry all parts and reassemble.

Test valve action with a screw driver inserted through the air ports. Each plate valve must lift and close freely. Replace seat gasket if damaged.

After inspecting or reconditioning compressor valves, return each to its original compartment. When replacing cover plates, back out adjusting screws sufficiently, so they will not engage when tightening cover plates on gaskets. Pull down adjusting screws on clamp and lock with clamp screw nuts.

BEARING ADJUSTMENT

Both tapered-roller main bearings are adjusted simultaneously, by removing shims from beneath the end plate to obtain proper end clearance.

To reduce crankpin bearing clearance, remove shim which is on one side of connecting rod only. Install replacement bearings so the small projection on the bearing fits the corresponding recess in the rod.

OVERHAULING

Replace the following if abnormally worn; crankpin bearing inserts, valve disks and springs, diaphragm, oil seals, gaskets and piston rings. See Table II, "minimum clearance and condemning limits."

TESTING ON LOCOMOTIVE

1. Connect an orifice holder (Fig. 8) with 0.125-inch diameter orifice, in the main-reservoir drain cock.
2. Start and run the compressor until it is at normal working temperature.
3. Close the outlet valve from the reservoirs and open the drain cock.

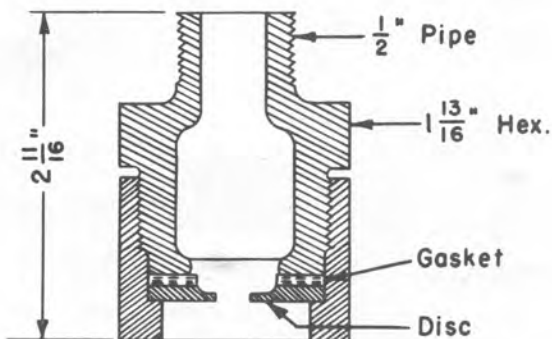
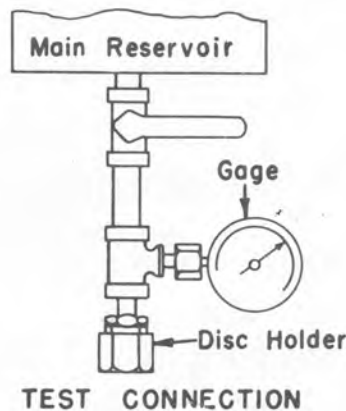
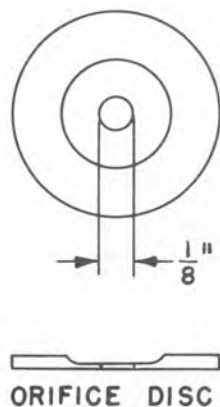
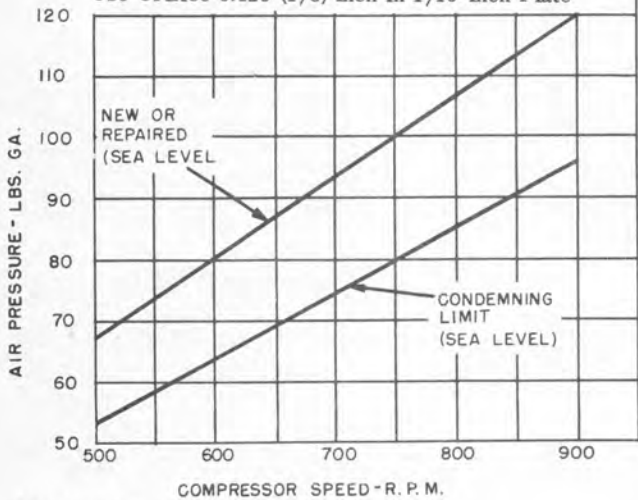

Fig. 8 (A-123955)

Fig. 8. Method of testing compressor on locomotive

GEI-37789C Air Compressor

Gardner-Denver Co., Quincy, Ill.
 Passing and Condemning Limits
 5 1/2 & 3 x 4 "ADS" Two-Stage Compressor
 Curve is for Sea Level Only
 Reduce Curve 1% per 260-ft Altitude *DC. 530 FT. ABOVE.*
 Use Orifice 0.125 (1/8) Inch in 1/16-Inch Plate



MADE FROM GARDNER-DENVER SHEET C-186-B

Fig. 9. Passing and condemning limits

4. After running the compressor for 2 minutes at a low compressor speed (Fig. 9), take a pressure reading. Record the compressor speed along

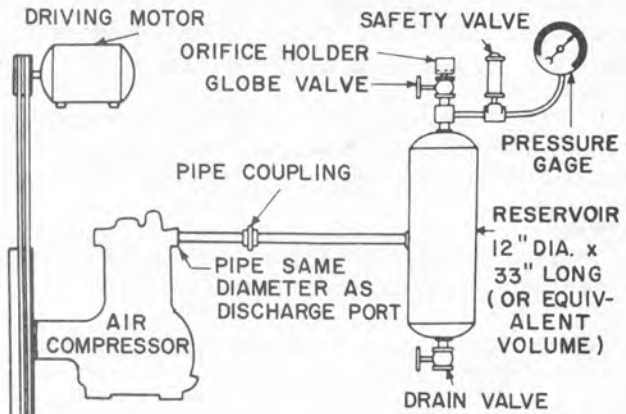

Fig. 10. Connections for orifice test on air compressor

with the corresponding pressure. Use an accurate air gage and speed recorder.

5. Take and record at least one more speed-pressure reading at a high compressor speed.

6. After running the compressor 15 minutes with the drain cock open, repeat steps 4 and 5.

**TABLE II
 MINIMUM CLEARANCE AND CONDEMNING LIMITS
 (ALL DIMENSIONS ARE IN INCHES)**

LP Ring to Groove	Min. Clearance	0.0010
	Limit	0.0100
HP Ring to Groove	Min. Clearance	0.0010
	Limit	0.0100
LP Ring Gap	Min. Clearance	0.0060
	Limit	0.0180
HP Ring Gap	Min. Clearance	0.0030
	Limit	0.0180
LP Piston to Cylinder	Min. Clearance	0.0040
	Limit	0.0120
HP Piston to Cylinder	Min. Clearance	0.0015
	Limit	0.0070
Conn. Rod Bearing to Crankpin	Min. Clearance	0.0010
	Limit	0.0050
Conn. Rod Bearing - Side Clearance	Min. Clearance	0.0100
	Limit	0.0180
Piston Pin to Bushing	Min. Clearance	0.0003
	Limit	0.0030
Valve Disks	Normal Thickness	0.0580
		0.0650
	Limit	0.0450
Main Bearing End Clearance	Minimum	0.0010
(Factory Setting)	Maximum	0.0030
Minimum Clearance Before Permitting Adjustment	Limit	0.0060

Fig. 9 (A-125096)
 Fig. 10 (A118796B)

Compare all speed-pressure readings with those on Fig. 9. If points fall below the CONDEMNING-LIMIT CURVE, overhaul the compressor.

7. When the above test is made on an overhauled compressor, the test readings should fall on, or above, the NEW or REPAIRED CURVE; otherwise correct the compressor.

8. The curves (Fig. 9) are for sea-level conditions. If tests are given at higher altitudes, plot

the appropriate CONDEMNING-LIMIT CURVE from data given in Table III.

TESTING ON BENCH

Set up equipment (Fig. 10) and follow same procedure for testing as given under TESTING ON LOCOMOTIVE. Select a motor which can deliver 10 hp to the compressor at full load.

**TABLE III
CONDEMNING-LIMIT VALUES**

Caterpillar D17000 Engine RPM	Cummins NHBIS-600 Engine RPM	Compressor RPM	ELEVATION IN FEET ABOVE SEA LEVEL <i>DL. 830 FT.</i>								
			Sea Level	1000	2000	3000	4000	5000	6000	7000	8000
			MIN. GAGE PRESSURE IN POUNDS TO BE MAINTAINED								
583	1190	500	53	51	49	47	45	43	41	39	36
643	1310	550	59	56	54	52	50	47	45	42	40
700	1430	600	64	61	59	56	54	51	49	46	44
759	1550	650	69	66	63	61	58	55	53	50	47
818	1670	700	74	71	68	65	63	60	57	55	51
875	1785	750	80	77	73	70	67	64	61	58	54
933	1900	800	85	82	78	75	71	68	65	61	58
992	2020	850	91	87	84	80	76	73	69	65	62
1050	2140	900	96	92	88	84	81	77	73	69	65

LOCOMOTIVE AND CAR EQUIPMENT DEPARTMENT

GENERAL  **ELECTRIC**

ERIE, PA.

REF. NO.	NAME OF PART	NO. REQ'D. PER COMP.	MODELS ADS-9000 THRU ADS-9005	MODELS ADS-9006 ADS-9007 ADS-9008	MODELS ADS-9009 THRU ADS-9014
	POWER END		SYMBOL	SYMBOL	SYMBOL
1	Crankcase Assembly	1	ACR-1A	ACR-1A	ACR-1A
4000	Crankcase Oil Drain Plug	2	64AA4	64AA4	64AA4
5652	Crankcase Oil Flange	1	22-AUX-27	22-AUX-27	22-AUX-27
4366	Crankcase Oil Flange Gasket	1	25C626	25C626	25C626
4365	Crankcase Oil Flange Screw	2	75AA1	75AA1	75AA1
4033	Cyl. & Brg. End Plate to Crankcase Screw or Stud	6	75A18	75A18	79A22
	Cyl. & Brg. End Plate to Crankcase Screw Washer	8	95H7	95H7	95H7
	Cyl. & Brg. End Plate to Crankcase Screw Nut	14	50B7	50B7	50B7
4119	Cyl. to Crankcase Screw or Stud	8	75A18	75A18	79A22
4	Crankshaft Assembly	1	VAB-569	VAB-569	1-ACR-4A
4263	Crankshaft Drive Key	1	35B81	35B81	35B81
4329	Crankshaft Drive Nut	1	VAB-381	VAB-381	VAB-381
4377	Crankshaft Drive Nut Screw	4	76F45	76F45	76F45
4013	Main Bearing	2	12C29	12C29	12C29
6	Bearing End Plate (Drive End)	1	VAB-6	5-VAB-6	5-VAB-6
4325	Bearing End Plate Oil Seal	1	60G23	60G23	60G23
4227	Bearing End Plate Shim (Set)	1	77B22	77B22	77B22
5658	Bearing Blind End Plug	1	66B2	None	None
6279	Bearing Blind End Plug Drive Screw	2	75K2	None	None
	Bearing End Plate Plug	2	None	None	64AA6
	Bearing End Plate Gasket	1	None	None	25C1997

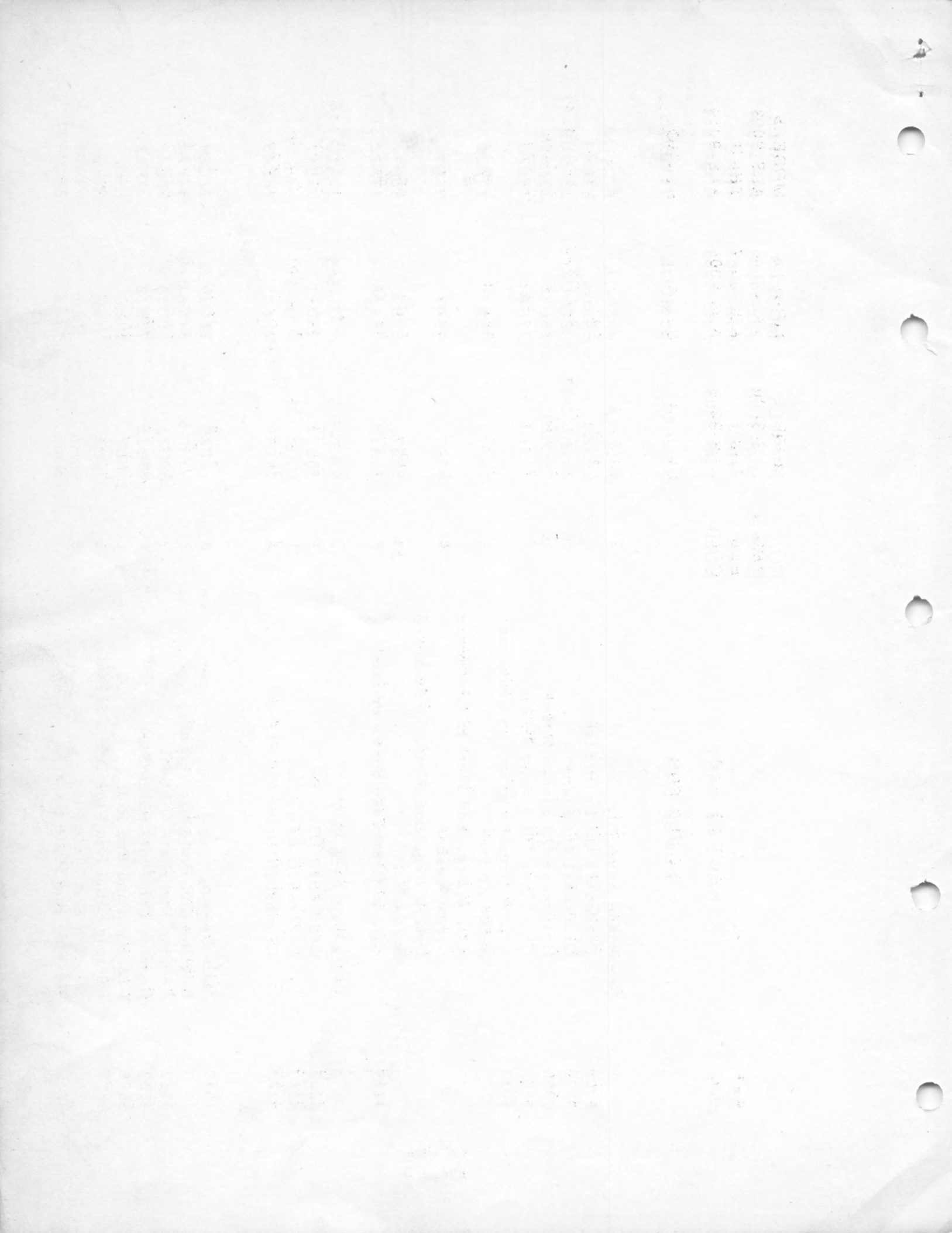

REF. NO.	NAME OF PART POWER END (Cont'd.)	NO. REQ'D. PER COMP.	MODELS ADS-9000 THRU ADS-9005	MODELS ADS-9006 ADS-9007 ADS-9008	MODELS ADS-9009 THRU ADS-9014
			SYMBOL	SYMBOL	SYMBOL
3	Connecting Rod Assembly	2	1-VAB-508	1-VAB-508	1-VAB-508
177	Piston Pin Clamp Screw	2	VAB-655	VAB-655	VAB-655
	Piston Pin Clamp Screw Wire	2	97A1	97A1	97A1
18-U	Crankpin Bearing (Upper Half) *	2	12T3	12T3	12T3
18-I	Crankpin Bearing (Lower Half) *	2	12U3	12U3	12U3
33	Cap to Rod Bolt	4	VAB-254	VAB-254	VAB-254
5632	Cap to Rod Bolt Nut	4	50E5	50E5	50E5
573	Cap to Rod Bolt Cotter	4	62E5	62E5	62E5
35	Conn. Rod Splash Pin	2	1-VAB-102	1-VAB-102	1-VAB-102
8-A	Handhole Plate (Plain)	1	AAL-9	AAL-9	AAL-9
8	Handhole Plate (Oil Gauge)	1	3-AAL-8	3-AAL-8	3-AAL-8
508	Handhole Plate Gasket	2	25C627	25C627	25C627
4031	Handhole Plate Screw	12	75A130	75A130	75A130
	Handhole Plate Plug	1	64A6	64A6	64A6
152	Oil Level Gauge Rod	1	ACR-557	ACR-557	ACR-557
4364	Oil Filler (Short Type)	1	ADS-32	ADS-32	ADS-32
4366	Oil Filler Gasket	1	25C626	25C626	25C626
4365	Oil Filler Screw	2	75AA1	75AA1	75AA1
4367	Crankcase Breather	1	5C8	5C8	5C8
5691	Crankcase Breather Holder	1	ADS-654	ADS-654	ADS-654
	Crankcase Breather Holder Screw	1	75G24	75G24	75G24
	Crankcase Breather Holder Screw Washer	1	95B13	95B13	95B13
	Crankcase Breather Holder Screw Nut	1	50K1	50K1	50K1

* Available in regular size and .030" undersize only, symbols 12T24 and 12U24.

When ordering a Sheave for Models ADS-9000 thru 9003, 9008, 9011 & 9014, order 11-ADR-99;
for Models ADS-9004 thru 9007, 9009, 9010, 9012 & 9013, order 3-ADS-99.

REF. NO.	NAME OF PART	NO. REQ'D. PER COMP.	MODELS ADS-9000 THRU ADS-9011	MODELS ADS-9012 ADS-9013 ADS-9014
LOW PRESSURE CYLINDER PISTON & AIR FILTER				
			SYMBOL	SYMBOL
2-LP 4080	LP Air Cylinder	1	ACS-2	ACS-2
	LP Air Cylinder to Crankcase Gasket	1	25C619	25C619
15-LP	LP Piston with Bushings *	1	1-ACS-576	3-ACS-15A
19-LP	LP Piston Bushing	2	12F54	12F54
9-LP	LP Piston Pin	1	62F32	62F32
16-LP	LP Piston Ring (Compression) *	3	65V14	65V14
16-ALP	LP Piston Ring (Oil Reg.) *	1	65S21	65S21
7-LP	Cylinder Head & Studs Assembly	1	ACS-505	ACS-505
523-LP	Valve Cover Plate Stud	8	79A67	79A67
524	Valve Cover Plate Stud Nut	8	50B7	50B7
502-LP	Head to Cylinder Gasket	1	25C1179	25C1179
4011	Head to Cylinder Screw	8	75A12	75A12
69	Suction Flange	1	ACR-69	ACR-69
516	Suction Flange Gasket	1	25C622	25C622
515	Suction Flange Screw	2	75A18	75A18
5659	Discharge Blank Flange	1	24-AUX-27	24-AUX-27
5660	Discharge Blank Flange Gasket	1	25C622	25C622
5661	Discharge Blank Flange Screw	2	75A18	75A18
4337	Suction Air Filter	1	5A97	5A97

* Available in Regular size and .010", .020" & .030" oversize.

REF. NO.	NAME OF PART	NO. REQ'D. PER COMP.	MODELS ADS-9000 THRU ADS-9011	MODELS ADS-9012 ADS-9013 ADS-9014
	LOW PRESSURE SUCTION UNLOADING VALVE		SYMBOL	SYMBOL
	LPS Unloading Valve Complete	1	3-ACS-526 *	ADS-164C
698	LPS Valve Assembly	1	1-AAD-506	ADS-164B
202-LP	LPS Valve Seat	1	3-YB-14	3-YB-14
200-LP	LPS Valve (Inner)	1	90E2	90E2
201-LP	LPS Valve (Outer)	1	90E1	90E1
188	LPS Valve Spring	6	78F4	78F4
134-LP	LPS Valve Bumper with Stud, Washer & Nut **	1	3-YB-128X	ADS-164A
204-LP	LPS Valve Bumper Stud**	1	79C22	79C25
5093	LPS Valve Bumper Washer **	1	95H5	95H5
5092	LPS Valve Bumper Nut **	1	50AH5	50AH5
4218-LP	LPS Valve Seat Gasket	1	25L5	25L5
217-LP	Lower Unloader Plunger	1	ABD-217	ABD-217
220-LP	Lower Unloader Plunger Spring	1	78A51	78A51
467-LP	Upper Unloader Plunger ***	1	ACS-467	ACS-467
5575	Upper Unloader Plunger Spring	1	78A126	78A126
5250	Upper Unloader Plunger Cotter	1	62E3	62E3
6271	Upper Unloader Plunger Nut	1	50E4	50E4
187-LPS	Suction Valve Clamp	1	ACS-194	ACS-194
189-LPS	Suction Valve Clamp Screw	3	76GG4	76GG4
5628	Suct. Valve Clamp Screw Gasket	3	25F15	25F15
526-LPS	Suct. Valve Clamp Screw Nut	3	50Q18	50Q18
185-LP	Suct. Valve Cover Plate	1	1-ABD-185	1-ABD-185
525-LPS	Suct. Valve Cover Plate Gasket	1	25R23	25R23
315	Unloader Diaphragm	1	2-AAB-215	2-AAB-215
274	Unloader Diaphragm Cap	1	WBY-274	WBY-274
530-LP	Unloader Diaphragm Cap Screw	3	75A130	75A130
	Unloader Diaphragm Cap Plug	1	64AA5	64AA5

* Complete Valve Assembly ACS-526 no longer furnished. The 3-ACS-526 Assembly must be ordered for repairs.

** Stud, Washer and Nut furnished with Bumper but they may be ordered separately.

*** The ABD-467 Upper Unloader Plunger is no longer furnished for repair. When a new Upper Unloader Plunger is required for Model ADS-9000, the ACS-467 must be ordered along with the 50E4 Nut and 62E3 Cotter.

REF. NO.	NAME OF PART	NO. REQ'D. PER COMP.	MODELS ADS-9000 THRU ADS-9011	MODELS ADS-9012 ADS-9013 ADS-9014
	LOW PRESSURE DISCHARGE VALVE		SYMBOL	SYMBOL
700-LP 203	LP Discharge Valve Assembly Valve Seat with Stud, Washer & Nut *	1	1-AAD-507	3-YB-127M
205-LP 5092	Valve Seat Stud *	1	3-YB-127X	3-YB-127X
5093	Valve Seat Stud *	1	79C25	79C25
200-LP	Valve Seat Nut *	1	50C5	50C5
201-LP	Valve Seat Washer *	1	95H5	95H5
188	Valve (Inner)	1	90E2	90E2
128-LP	Valve (Outer)	1	90E1	90E1
4218-LP	Valve Spring	6	78F4	78F4
	Valve Bumper	1	4-YB-128	ADS-128
	Valve Seat Gasket	1	25L5	25L5
187-LPD	Valve Clamp	1	AAD-194	3-AAD-194
189-LPD	Valve Clamp Screw	1	76GG2	76GG2
5094-LPD	Valve Clamp Screw Gasket	1	25F13	25F13
526-LPD	Valve Clamp Screw Nut	1	50Q17	50Q17
11-LP	Valve Cover	1	AAD-11	AAD-11
525-LPD	Valve Cover Gasket	1	25R23	25R23

* Stud, Washer and Nut furnished with Seat but they may be ordered separately.

REF. NO.	NAME OF PART	NO. REQ'D. PER COMP.	MODELS ADS-9000 THRU ADS-9014
HIGH PRESSURE CYLINDER & PISTON			SYMBOL
2-HP	HP Air Cylinder *	1	5-ADS-2
4080	HP Cylinder to Crankcase Gasket	1	25C619
15-HP	HP Piston with Bushings **	1	1-ADS-576
19-HP	HP Piston Bushing	2	12F55
9-HP	HP Piston Pin	1	62F33
16-HP	HP Piston Ring (Compression) **	3	65V3
16-AHP	HP Piston Ring (Oil Reg.) **	1	65S11
7-HP	Cylinder Head & Studs Assembly	1	2-ADR-505
523-HP	Valve Cover Plate Stud	6	79A67
524	Valve Cover Plate Stud Nut	6	50B7
5666	Cylinder Head Plug	1	64AA5
502-HP	HP Head to Cylinder Gasket	1	25C1189
4011	HP Head to Cylinder Screw	8	75A12
5547	HP Discharge Flange	1	ABL-73
5548	HP Discharge Flange Gasket	1	25C628
5549	HP Discharge Flange Screw	4	75A39

* When a new Cylinder 5-ADS-2 is ordered for Models ADS-9000 thru ADS-9005, a new Piston 1-ADS-576 must also be ordered.

** Available in Regular size and .010", .020" & .030" oversize.

REF. NO.	NAME OF PART	NO. REQ'D. PER COMP.	MODELS ADS-9000 THRU ADS-9014
HIGH PRESSURE SUCTION UNLOADING VALVE			SYMBOL
HPS Unldg. Valve Assembly Complete 1-ABL-526 *			
(1 required)			
698-HP	HPS Valve Assembly	1	ABL-563
202-HP	Valve Seat	1	ABL-202
200-HP	Valve	1	90E3
188	Valve Spring	3	78F4
134-HP	Valve Bumper with Stud, Washer & Nut **	1	ABL-164X
204-HP	Valve Bumper Stud **	1	79C25
5092	Valve Bumper Nut **	1	50AH5
5093	Valve Bumper Washer **	1	95H5
4218-HP	Valve Seat Gasket	1	25L3
217-HP	Lower Unloader Plunger	1	ABL-217
220-HP	Lower Unloader Plunger Spring	1	78A124
467-HP	Upper Unloader Plunger ***	1	1-ABL-467
5250	Upper Unloader Plunger Cotter	1	62E3
5575	Upper Unloader Plunger Spring	1	78A126
6271	Upper Unloader Plunger Nut	1	50E4
187-HPS	Valve Clamp	1	ABL-194
189-HPS	Valve Clamp Screw	3	76G55
5094-HPS	Valve Clamp Screw Gasket	3	25F15
526-HPS	Valve Clamp Screw Nut	3	50Q13
185-HP	Valve Cover	1	ABL-185
525-HPS	Valve Cover Gasket	1	25R4
315	Diaphragm	1	2-AAB-215
274	Diaphragm Cap	1	WBY-274
530-HP	Diaphragm Cap Screw	6	75A34
5929-HP	Diaphragm Cap Plug	1	64AA5

* Complete Valve Assembly ABL-526 no longer furnished.
The 1-ABL-526 Assembly must be ordered for repair.

** Stud, Washer and Nut furnished with Bumper but they may be ordered separately.

*** The ABL-467 Upper Unloader Plunger is no longer furnished for repair. When a new upper Unloader Plunger is required for Models ADS-9000, the 1-ABL-467 must be ordered along with the 50E4 Nut and 62E3 Cotter.

REF. NO.	NAME OF PART	NO. REQ'D. PER COMP.	MODELS ADS-9000 THRU ADS-9014
HIGH PRESSURE DISCHARGE VALVE			SYMBOL
700-HP	HPD Valve Assembly	1	ABL-507
203-HP	Valve Seat with Stud, Washer & Nut *	1	2-YA-127X
205-HP	Valve Seat Stud *	1	79C25
5093	Valve Seat Stud Washer *	1	95H5
5092	Valve Seat Stud Nut *	1	50C5
200-HP	Valve	1	90E3
188	Valve Spring	3	78F4
128-HP	Valve Bumper	1	ABL-128
4218-HP	Valve Seat Gasket	1	25L3
187-HPD	HPD Valve Clamp	1	1-ABL-194
189-HPD	HPD Valve Clamp Screw	1	76GG2
5094-HPD	HPD Valve Clamp Gasket	1	25F13
526-HPD	HPD Valve Clamp Screw Nut	1	50Q17
11-HP	HPD Valve Cover	1	ABL-11
525-HPD	HPD Valve Cover Gasket	1	25R4

* Stud, Washer and Nut furnished with Bumper but they may be ordered separately.

REF. NO.	NAME OF PART	NO. REQ'D. PER COMP.	MODELS	MODELS
			ADS-9000 ADS-9001 ADS-9002 ADS-9003 ADS-9005 ADS-9007 ADS-9008 ADS-9010 ADS-9011 ADS-9013 ADS-9014	ADS-9004 ADS-9006 ADS-9009 ADS-9012
INTERCOOLER			SYMBOL	SYMBOL
5719	Intercooler Assembly	1	3-ADS-598	10-ADS-598
476-LP	Header (LP)	1	ADS-476A	ADS-476A
476-HP	Header (HP)	1	1-ADS-476A	7-ADS-476A
4234	Tube with Nuts (Top)	1	3-ADS-243	3-ADS-243
4234	Tube with Nuts (Next to Top)	1	3-ADS-243	8-ADS-243
4234	Tube with Nuts (Next to Bottom)	1	3-ADS-243	7-ADS-243
4234	Tube with Nuts (Bottom)	1	3-ADS-243	6-ADS-243
4238	Tube Brace	1	ADS-613	ADS-613
4239	Tube Brace Screw	4	75A183	75A183
5663	Tube Brace Spacer	4	80A52	80A52
5662	Tube Brace Nut	3	50B1	50B1
5664	Intercooler Header Plug (1/4")	1	64AA5	None
5664-A	Intercooler Header Plug (1")	See ()	64A6 (4)	64A6 (3)
4567-1	Intercooler Header Drain Cock	2	90W1	90W1
4612	Intercooler Safety Valve	1	90G211	90G211
5665	Intercooler Safety Valve St. Elbow	1	64D10	64D10
5576	Intercooler to Head Gasket	2	25C622	25C622
5584	Intercooler to Head Screw	4	75A18	75A18
4950	Int. Pressure Gauge St. Elbow	1	64D2	64D2
	Int. Pressure Gauge Opening Plug	1	64AA5	None

If desired, a 27A15 Pressure Gauge can be furnished.

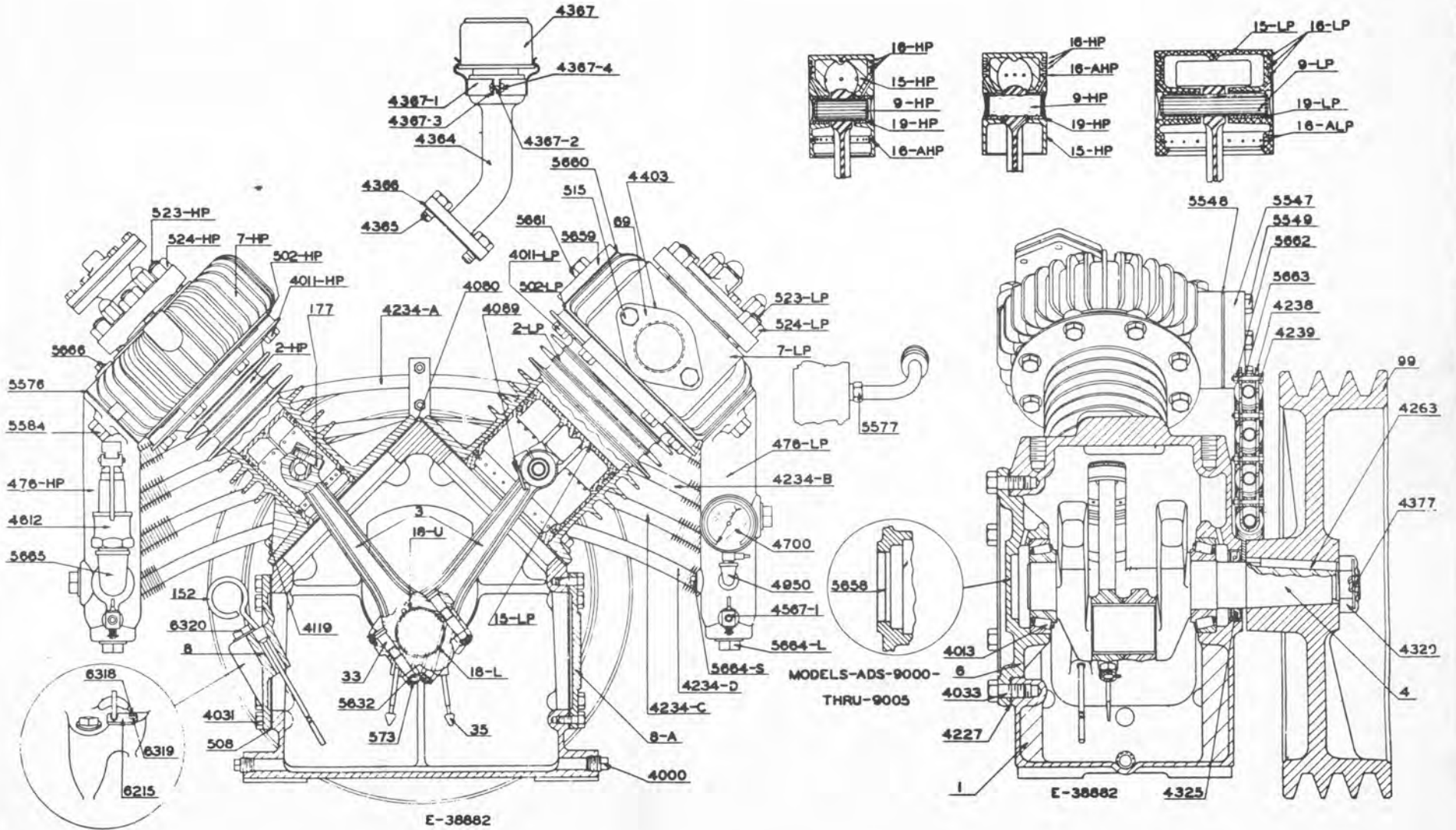

S-16, S-16-C and NS-16 COMPRESSOR GOVERNORS

Parts Catalog No. 3205-10

July, 1954

(Superseding Issue of October, 1947)

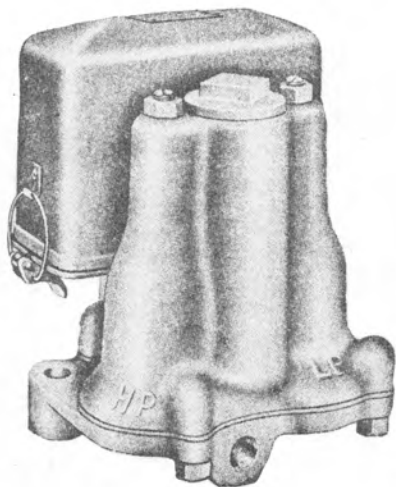

(Type S-16)

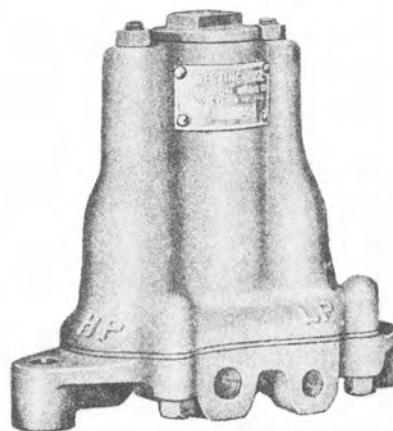

(Type NS-16)

Westinghouse Air Brake COMPANY

AIR BRAKE DIVISION



WILMERDING, PA.

S-16 AND S-16-C ELECTRIC COMPRESSOR GOVERNOR

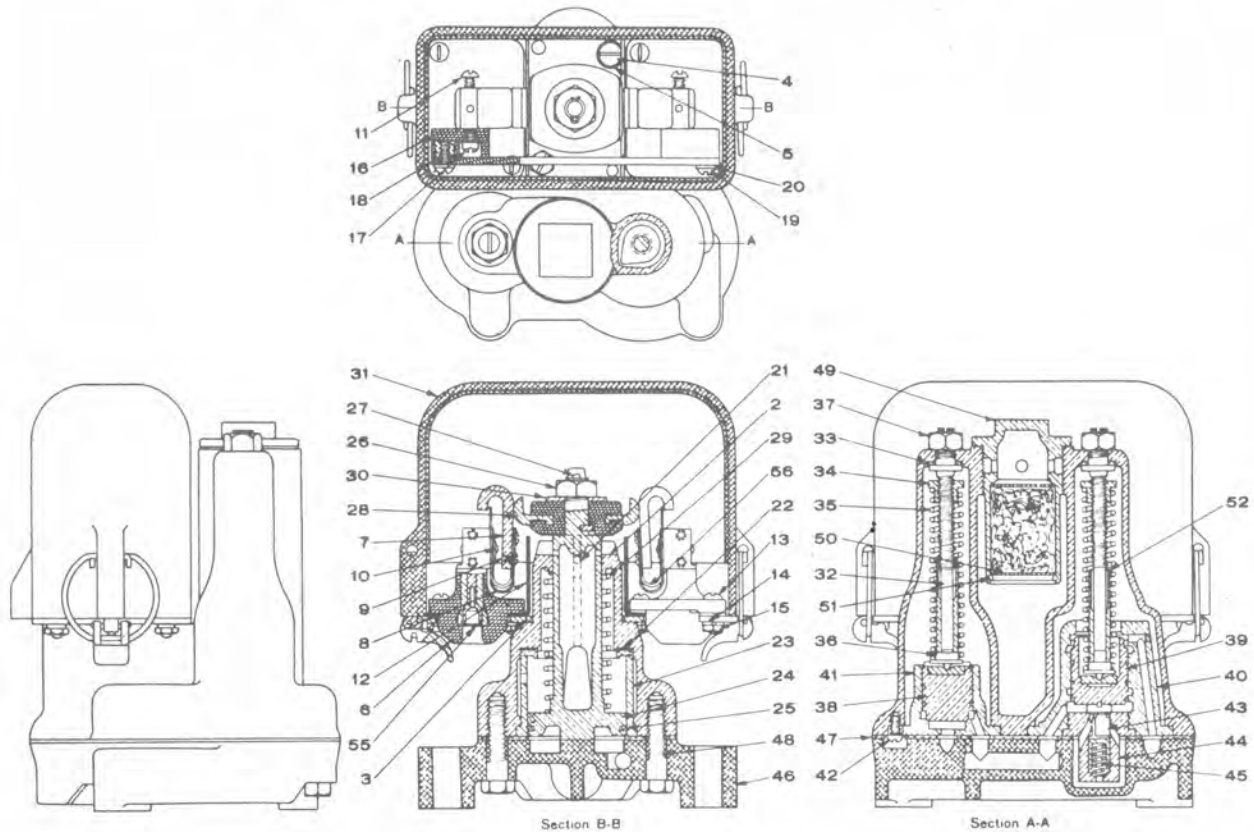

Net Weight 21 lbs.

The S-16 and the S-16-C Electric Compressor Governors differ only in that the S-16-C has an additional 1/4" pipe tap in the Bracket, opposite the 3/8" pipe tap to Main Reservoir, which is used for operating a Drain Valve.

TYPE	COMPLETE Pc. No.	PRESSURE RANGE† (See Ref.No.35)	BODY Pc. No. Ref. No. 2	BRACKET Pc. No. Ref. No. 46	TERMINAL Pc. No. Ref. No. 55	REMARKS
S-16	501413	60 to 160 lbs.	540414	93560	Standard Body and Bracket
S-16	501414	40 to 60 lbs.	540414	93560	Standard Body and Bracket
S-16	509266	60 to 160 lbs.	77686	93560	93334	Brass Body
S-16	516195	150 to 250 lbs.	540414	516196	Brass Bracket
S-16	541560	60 to 160 lbs.	540414	93560	93334	Standard Body and Bracket
S-16-C	*533631	60 to 160 lbs.	77686	533630	93334	Brass Body
S-16-C	534088	60 to 160 lbs.	77686	533630	93334	Brass Body
S-16-C	539518	60 to 160 lbs.	540414	533630	93334	Standard Body and Bracket

*NOTE:—For A-1 and A-2 Compressor Units.

†NOTE:—The complete piece numbers as shown, cover the governors having the spring ranges indicated. Piece numbers are coded by the use of four digit suffixes to express the actual pressure settings. The first digit indicates the pressure difference between cut-in and cut-out pressure as shown in the table. The last three digits indicate the cut-out pressure.

Numeral	Pressure Difference	Example:
1	10	Pc. 501413-4140—Set 115 to 140 lbs. Pc. 501414-1050—Set 40 to 50 lbs.
2	15	
3	20	
4	25	
5	40	
6	30	

Prices will be quoted upon application.
 Orders should give PIECE NUMBER and NAME of part wanted.

S-16 AND S-16-C ELECTRIC COMPRESSOR GOVERNOR

For Complete Piece Numbers, see page 2.

Pc. No.	Ref. No.	Description	Pc. No.	Ref. No.	Description
72906	2	Body (See Schedule)	538985	28	Switch Contact, Complete (for Pc. 533631)
72944	3	Finger Base Plate, Complete, with Latches	†81836	29	Piston Spring
10764	4	1/4" x 3/8" Hex Hd. Cap Screw (2 Req'd)	16351	30	Piston Washer
539211	5	1/4" Lock Washer (2 Req'd)	501411	31	Cover, Complete
72911	6	Finger Base, Complete (Includes 6, Pc. 539939 and two of 11) (2 Req'd)	72936	32	Adjusting Stem (2 Req'd)
539939	7	Finger, Complete (Includes 7, 8, three of 9 and six of 56) (2 Req'd)	73588	33	Adjusting Stem Washer (2 Req'd)
72914	8	Finger Spring (2 Req'd)	72938	34	Adjusting Nut (2 Req'd)
539168	9	Finger Screw (6 Req'd)	†544590	35	Adjusting Spring (150 to 250 lbs.) (2 Req'd)
3805	10	Finger Washer (2 Req'd)	†72974	35	Adjusting Spring (60 to 160 lbs.) (2 Req'd)
72917	11	Lead Screw (4 Req'd)	†1498	35	Adjusting Spring (40 to 60 lbs.) (2 Req'd)
21696	12	Finger Base Insulation (2 Req'd)	72940	36	Adjusting Spring Seat (2 Req'd)
79427	13	Finger Base Screw (4 Req'd)	27342	37	3/8" Hex Nut (2 Req'd)
13322	14	#10 Lock Washer (4 Req'd)	72941	38	Cut Out Valve
7982	15	#10 Hex Nut (4 Req'd)	72945	39	Cut In Valve
17154	16	Arc Shield Spacer (2 Req'd)	72947	40	Cut In Valve Seat
72919	17	Arc Shield Spacer Screw (4 Req'd)	72949	41	Cut Out Valve Seat
22878	18	Arc Shield	12143	42	Valve Seat Screw (4 Req'd)
72920	19	Arc Shield Screw (4 Req'd)	72950	43	Cut In Tail Valve
17054	20	3/8" x 1/32" x 1/16" Washer (8 Req'd)	72951	44	Cut In Tail Valve Seat
8146	21	Switch Piston Guide Pin	†72952	45	Cut In Tail Valve Spring
16955	22	Piston Seal	46	Bracket (See Schedule)	
538946	23	Piston Bush	72960	47	Bracket Gasket
72922	24	Switch Piston, Complete (Includes 24, 25b, 26 and 27)	7978	48	3/8" x 1" Bracket Cap Screw (for Pc. 516195) (4 Req'd)
79430	25a	Piston with Pin	25410	48	3/8" x 1 3/8" Bracket Cap Screw (4 Req'd)
79428	25b	Piston Ring (1st Repair)	72961	49	Strainer, Complete (Includes 49, 51 and two of 50)
534539	25c	Piston Ring (2nd Repair)	72962	49	Strainer Case
72926	26	Piston Nut	72963	50	Strainer Plate (2 Req'd)
73558	27	3/32" x 1/2" Cotter	72964	51	Strainer Plate Retainer
5489	28	Switch Contact, Complete (for Pc. Nos. 501413, 501414, 509266, 516195, 534088, 539518 and 541560)	525625	52	Adjusting Stem Sleeve (2 Req'd)
4045			93334	55	Terminal Sleeves (2 Req'd) (See Schedule)
72927			72916	56	Finger Spring Lamination (12 Req'd)

SPRING IDENTIFICATION

†NOTE:—The following table is shown to enable railroad men, storekeepers and all Air Brake men to identify the various springs used in the Governors cataloged herein. It is based on calculated figures and the actual springs will vary somewhat, due to small differences in wire diameter, coil diameter, number of turns, etc. This tabulation is intended for identification only and should not be used for any other purpose. It does not represent a specification for the springs mentioned.



SPRING IDENTIFICATION

Pc. No.	Approx. Outside Dia. "A"	Approx. Dia. Wire "B"	Approx. Free Height "C"	*Approx. No. Turns	Material	Name of Spring	Where Used
81836	1 3/16"	.1205"	3 1/64"	11	Steel	Piston Spring	S-16 Governor
544590	4 7/64"	.146"	3.4375"	18	Steel	Piston Spring	S-16 Governor
72974	2 1/32"	.092"	3 11/16"	20	Steel	Adjusting Spring	S-16 & NS-16 Governors
1498	5/8"	.092"	3 1/4"	20	Steel	Adjusting Spring	S-16 & NS-16 Governors
72952	1 1/4"	.0253"	1 3/32"	19	Phosphor Bronze	Tail Valve Spring	S-16 & NS-16 Governors

*Number of turns for each spring, counted between extreme ends of the wire.

Prices will be quoted upon application.
Orders should give PIECE NUMBER and NAME of part wanted.

NS-16 COMPRESSOR GOVERNOR

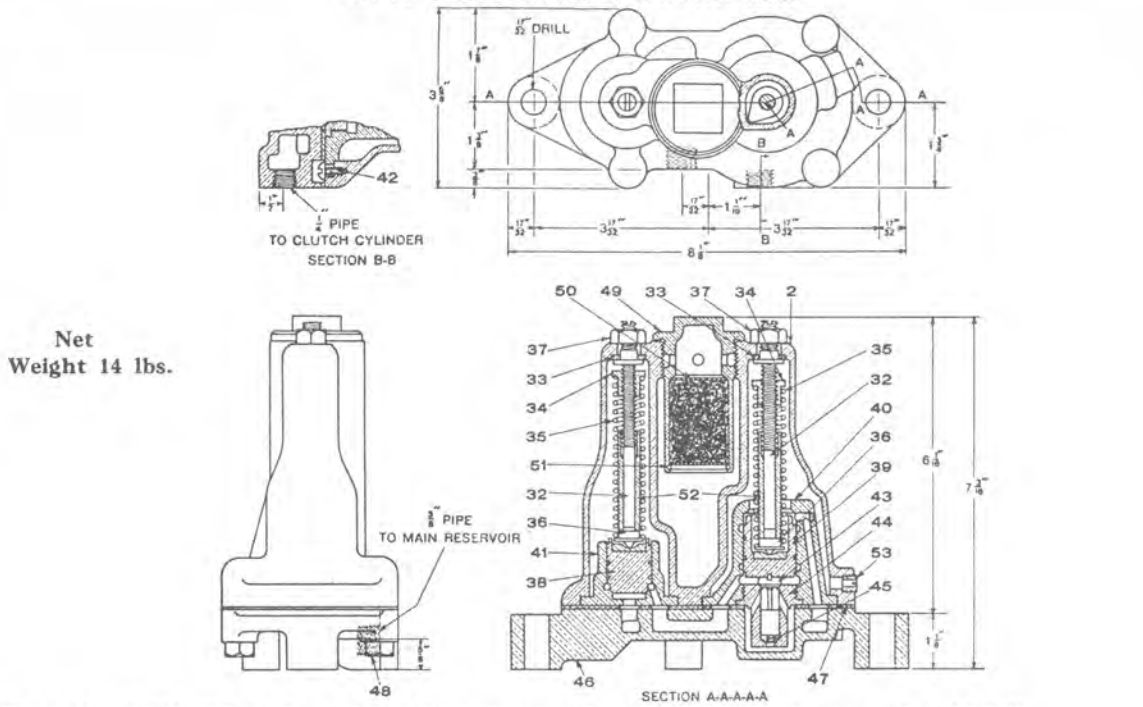

Net Weight 14 lbs.

- † Piece No. 85270 NS-16 Compressor Governor, complete, for Pressures between 60 and 160 lbs.
- † Piece No. 534623 NS-16 Compressor Governor, complete, for Pressures between 20 and 60 lbs.
- † Piece No. 518702 NS-16 Compressor Governor, complete, with Bracket for 3-CD Compressor, for Pressures between 60 and 160 lbs. (See illustration below)

Pc. No.	Ref. No.		Pc. No.	Ref. No.	
79499	2	Body (includes 53)	72950	43	Cut In Tail Valve
72936	32	Adjusting Stem (2 Req'd)	72951	44	Cut In Tail Valve Seat
73588	33	Adjusting Stem Washer (2 Req'd)	†72952	45	Cut In Tail Valve Spring
72938	34	Adjusting Nut (2 Req'd)	509657	46	Bracket
†72974	35	Adjusting Spring (60 to 160 lbs. Pressure) (2 Req'd)	518700	46	Bracket for Mounting on 3-CD Compressor (See illustration below)
† 1498	35	Adjusting Spring (20 to 60 lbs. Pressure) (2 Req'd)	77736	47	Bracket Gasket
72940	36	Adjusting Spring Seats (2 Req'd)	3210	48	3/8" x 1 1/4" Cap Screw (4 Req'd)
27432	37	3/8" Hex. Nut (2 Req'd)	72961	49	Strainer, complete (includes 51 and two of 50)
72941	38	Cut Out Valve	72963	50	Strainer Plates (2 Req'd)
72945	39	Cut In Valve	72964	51	Strainer Plate Ring
72947	40	Cut In Valve Seat	525625	52	Adjusting Stem Sleeve (2 Req'd)
72949	41	Cut Out Valve Seat	78727	53	1/8" Choke Plug
44519	42	Valve Seat Screws (4 Req'd)			

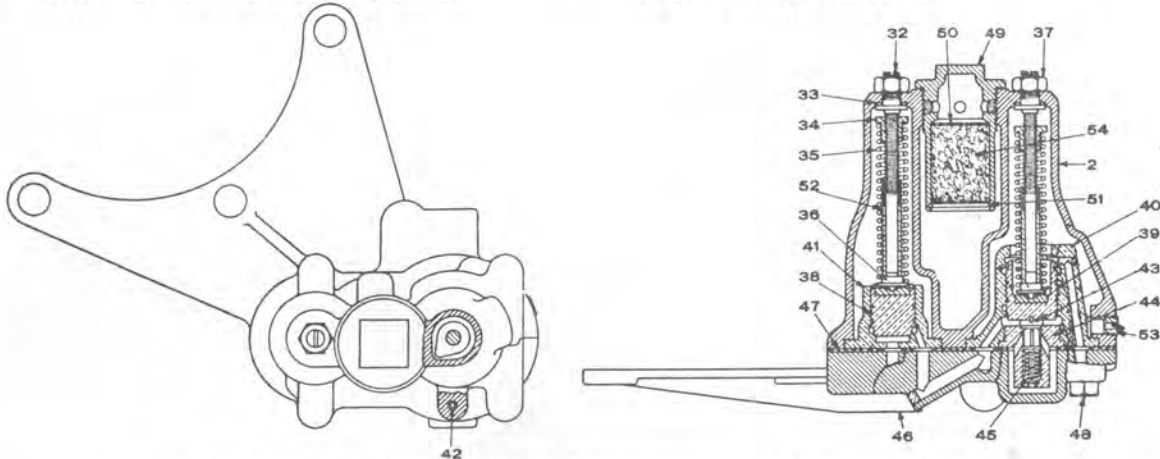

NS-16 Governor with Bracket for 3-CD Compressor, Net Weight 15 lbs.

†NOTE:—For Spring Identification Table, see page 3.
 ‡NOTE:—See Piece Number Coding Information outlined on page 2.

Prices will be quoted upon application
 Orders should give PIECE NUMBER and NAME of part wanted.

K14 and L14 TYPES BRAKE VALVE

Part Catalog No. 3208-4

August, 1949
Reprinted April, 1955

(Superseding Part Catalog No. T-3508-6 of March, 1941 and Temporary
Part Catalog No. 3208-4 of May, 1927)

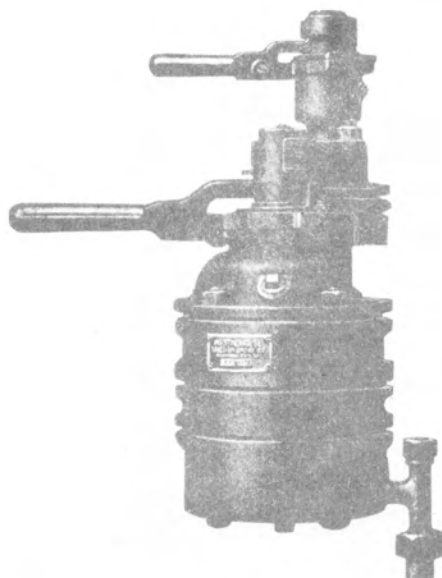

Westinghouse Air Brake COMPANY

AIR BRAKE DIVISION



WILMERDING, PA.

K-14-A AND K-14-E BRAKE VALVES

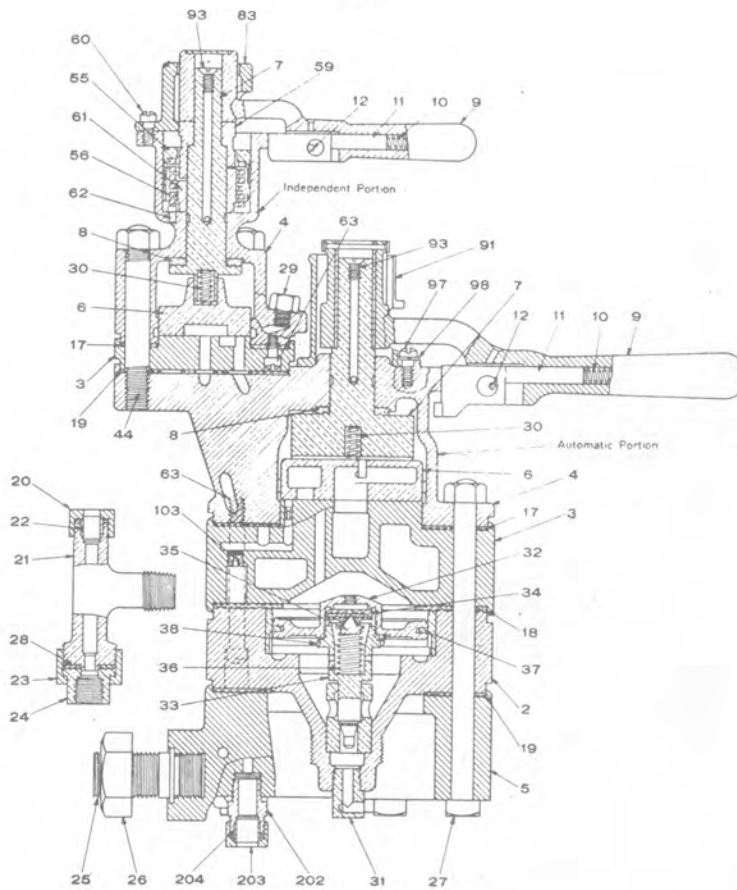
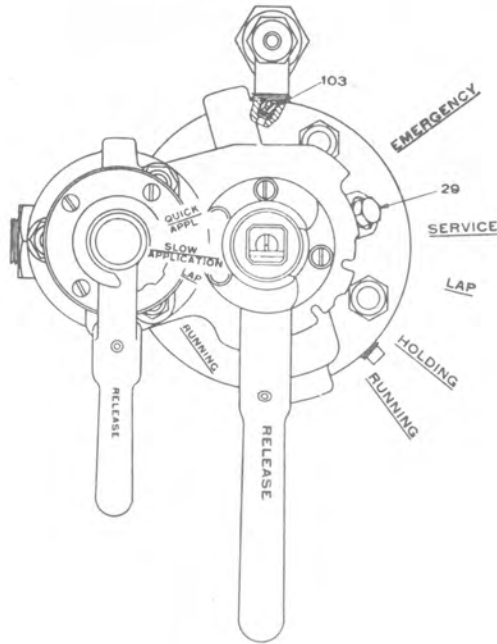

Approx. Net Weight 70 lbs.

K-14-A AND K-14-E BRAKE VALVES

Type	BRAKE VALVE			Automatic Portion		Independent
	COMPLETE PIECE NOS.			Pc. Nos.		Portion Pc. Nos.
	Less Handles	Less Handles, Tee and Stud Fittings	Less Pipe Bracket, Handles, Tee and Stud Ftg.s.	With Pipe Bracket, Less Handle	Less Pipe Bracket and Handle	Less Handle
K-14-A	67360		67361	67746	67362	32254
K-14-E	89316	536157	515431	67746	67362	510839

AUTOMATIC PORTION

Piece No.	Ref. No.	†No. Per Pkg.	Description	Piece No.	Ref. No.	†No. Per Pkg.	Description
86541	2		Bottom Case, complete, (Includes 31)	*13109	30	50	Rotary Valve Spring
86537	3		Valve Seat (Includes two of 103)	14464	31		Exhaust Fitting
29021	4		Body, complete, (Includes 29)	†95172			Equalizing Piston with By-Pass Check Valve, complete, (Includes 32, 33, 34, 35, 36, 37 and 38)
28757	5		Pipe Bracket, complete, (Includes 25, 26 and two of 1635)	98166	32		Piston
59080	6	1	Rotary Valve	98168	33		Piston Stem
12360	7	2	Rotary Valve Key (Includes 93)	98170	34		Check Valve
1998	8		Key Washer	98169	35		Spring Seat
19203	9	6	Brass Handle, complete, (Includes 10, 11 and 12) (See Notes B and C)	*98165	36		Spring
*1367	10	50	Latch Spring	85811	37	50	3 1/2" Piston Ring (1st Repair)
19200	11		Latch	85812	37	50	3 1/2" Piston Ring (2nd Repair)
1368	12		Latch Screw	85813	37	50	3 1/2" Piston Ring (3rd Repair)
86249	17		Upper Gasket	85814	37	50	3 1/2" Piston Ring (4th Repair)
86248	18		Middle Gasket	501395	38		Lock Washer
12303	19		Lower Gasket	14035	44		Stud and Nut (3 Req'd)
86765			Gage and Equalizing Reservoir Tee Connection, complete, (Includes 20, 21, 22, 23, 24 and 28)	3077	63		Fil. Head Screw (2 Req'd)
71748	20	50	Gage Union Nut for 3/8" Copper Tubing	19202	91		Handle Guard
86764	21		Gage and Equalizing Reservoir Tee	22262	93		Oil Screw
71727	22	100	Gage Union Thimble for 3/4" Copper Tubing	12304	97		Handle Guard Screw (4 Req'd)
35299	23		3/8" Union Nut	10764	98		Lock Washer (4 Req'd)
2005	24	12	3/8" Union Swivel	515794	103		1/2" Pipe Plug (2 Req'd)
2009	25		Holding Stud	71544			Union Stud Connection for 1/2" Copper Tubing (Includes 202, 203 and 204) (2 Req'd)
2010	26		Holding Nut	71545	202		Union Stud (2 Req'd)
20294	27		Bolt and Nut (4 Req'd)	71542	203		Union Nut (2 Req'd)
89185	28		Gasket	71543	204	100	Thimble (2 Req'd)
6753	29		Oil Plug	1635			1/4" Pipe Plug (2 Req'd)

INDEPENDENT PORTION

Piece No.	Ref. No.	†No. Per Pkg.	Description	Piece No.	Ref. No.	†No. Per Pkg.	Description
15300	3		Valve Seat (For K-14-A)	81248	17		Upper Gasket
88239	3		Valve Seat (For K-14-E)	81247	19		Lower Gasket
17649	4		Body, complete, (Includes 29 and 62)	6753	29		Oil Plug
511878	6		Rotary Valve (For K-14-A)	*13109	30	50	Rotary Valve Spring
510838	6		Rotary Valve (For K-14-E)	515821	55	5	Return Spring Housing
17615	7	6	Rotary Valve Key (Includes 93)	*17445	56		Return Spring
6760	8		Key Washer	19071	59		Upper Clutch
12354	9	4	Brass Handle, complete, (Includes 10, 11 and 12) (See Notes B and C)	12304	60		Handle Guard Screw (3 Req'd)
*9810	10		Latch Spring	19070	61		Lower Clutch
11932	11		Latch	17138	62		Return Spring Stop
1368	12		Latch Screw	12304	63		Fil. Head Screw (2 Req'd)
				532087	83		Handle Guard
				22262	93		Oil Screw

*NOTE A—For Spring Identification Table, see page 8.

NOTE B—If Malleable Iron Handles are desired, specify as follows:
Pc. No. 19204 Automatic Portion Handle, complete (Includes 10, 11 and 12)
Pc. No. 18754 Independent Portion Handle, complete (Includes 10, 11 and 12)

NOTE C—If repair Bush for Handles are desired, specify as follows:
Piece No. 69167 Repair Bush for Handle for Automatic Valve.
Piece No. 57359 Pin for Repair Bush for Handle.
Piece No. 68596 Repair Bush for Handle for Independent Valve.

NOTE D—If repairs for old style Collapsible Equalizing Piston are desired, specify as follows:

Pc. No.	Description	Pc. No.	Description
29303	Collapsible Equalizing Piston, complete	66773	Rivet
66774	Rivet with Cotter (includes Pcs. 66772 and 66773)	*29353	Spring
66772	Cotter	85812	Piston Ring (2nd Repair)
29300	Valve		

†NOTE E—Unless otherwise specified second Repair Ring Pc. 85812 is furnished with Pc. No. 95172 (Piston with Ring). We are prepared to furnish gages for use in determining the correct size of ring to be applied to the bushing being refitted and we strongly recommend the use of these gages.

†NOTE F—Column headed "No. Per Pkg." indicates the items for which standard shipping packages have been established and the number contained in the package. Orders placed in these quantities and multiples thereof will facilitate shipments and provide convenient means for handling in store room stock.

Prices will be quoted upon application
Orders should give PIECE NUMBER and NAME of part wanted

K-14-B AND K-14-F BRAKE VALVES

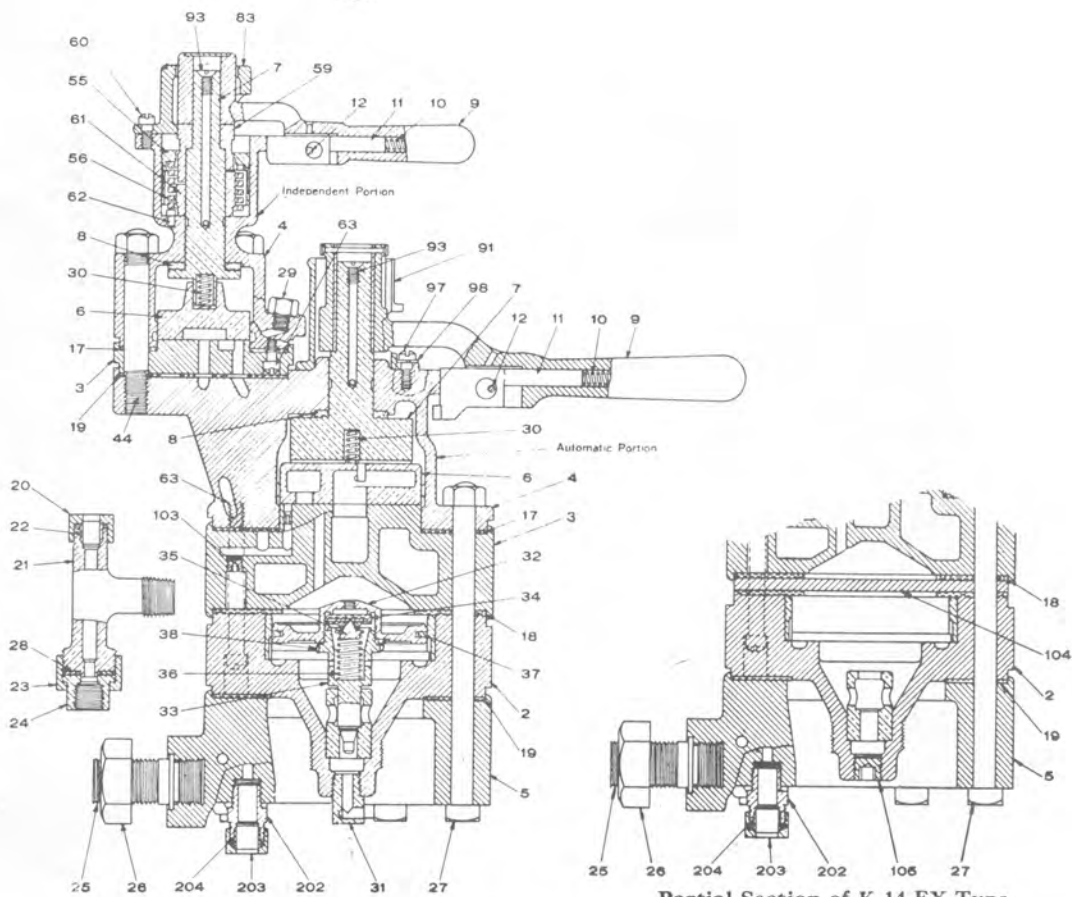
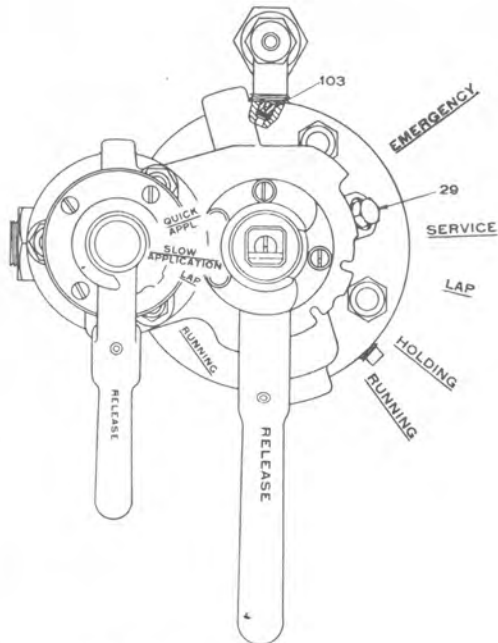

Partial Section of K-14-FX Type

Approx. Net Weight 70 lbs.

K-14-B, K-14-F AND K-14-FX BRAKE VALVES

Type	BRAKE VALVE COMPLETE PIECE NOS.			Automatic Portion Pc. Nos.		Independent Portion Pc. Nos.
	Less Handles	Less Handles, Tee and Stud Fittings	Less Pipe Bracket, Handles, Tee and Stud Ftgs.	With Pipe Bracket, Less Handle	Less Pipe Bracket and Handle	Less Handle
K-14-B	67307	518027	67309	67747	73593	32254
K-14-F	514801	521414	515994	67747	73593	510839
K-14-FX	533389		538111	533390	538110	510839

AUTOMATIC PORTION

Piece No.	Ref. No.	†No. Per Pkg.	Description	Piece No.	Ref. No.	†No. Per Pkg.	Description
86541	2		Bottom Case (Includes 31) (for K-14-B and K-14-F)	25219	27		Bolt and Nut (4 Req'd for K-14-FX)
536793	2		Bottom Case (Includes 105) (for K-14-FX)	89185	28		Gasket for 3/8" Union Swivel
86537	3		Valve Seat (Includes two of 103)	6753	29		Oil Plug
29021	4		Body, complete, (Includes 29)	*13109	30	50	Rotary Valve Spring
28757	5		Pipe Bracket, complete, (Includes 25, 26 and two of Pc. 1635)	14464	31		Exhaust Fitting (for K-14-B and K-14-F)
59078	6	1	Rotary Valve (for K-14-B and K-14-F)	†95172			Equalizing Piston with By-Pass Check Valve, complete (Includes 32, 33, 34, 35, 36, 37 and 38) (for K-14-B and K-14-F)
533386	6		Rotary Valve (for K-14-FX)	98166	32		Piston
12360	7	2	Rotary Valve Key (Includes 93)	98168	33		Piston Stem
1998	8		Key Washer	98170	34		Check Valve
19203	9	6	Brass Handle, complete, (Includes 10, 11 and 12)	98169	35		Spring Seat
*1367	10	50	Latch Spring	*98165	36		Spring
19200	11		Latch	85811	37	50	3 1/2" Piston Ring (1st Repair)
1368	12		Latch Screw	85812	37	50	3 1/2" Piston Ring (2nd Repair)
86249	17		Upper Gasket	85813	37	50	3 1/2" Piston Ring (3rd Repair)
86248	18		Middle Gasket (2 Req'd for K-14-FX; 1 Req'd for K-14-B and K-14-F)	85814	37	50	3 1/2" Piston Ring (4th Repair)
12303	19		Lower Gasket	501395	38		Lock Washer
86765			Gage and Equalizing Reservoir Tee Connection, complete (Includes 20, 21, 22, 23, 24 and 28) (Not included in K-14-FX)	14035	44		Stud and Nut (3 Req'd)
71748	20	50	Gage Union Nut for 3/8" Copper Tubing	3077	63		Fil. Head Screw (2 Req'd for K-14-B and K-14-F)
86764	21		Gage and Equalizing Reservoir Tee	534813	63		Fil. Hd. Screw (2 Req'd for K-14-FX)
71727	22	100	Gage Union Thimble for 3/8" Copper Tubing	19202	91		Handle Guard
35299	23		3/8" Union Nut	22262	93		Oil Screw
2005	24	12	3/8" Union Swivel	12304	97		Handle Guard Screw (4 Req'd)
2009	25		Holding Stud	10764	98		Lock Washer (4 Req'd)
2010	26		Holding Nut	515794	103		1/8" Pipe Plug (2 Req'd)
20294	27		Bolt and Nut (4 Req'd for K-14-B and K-14-F)	533387	104		Equalizing Piston Blanking Plate (for K-14-FX)
				520379	105		Exhaust Port Plug (for K-14-FX)
				71544			Union Stud Connection for 1/2" Copper Tubing (Includes 202, 203 and 204) (2 Req'd)
				71545	202		Union Stud (2 Req'd)
				71542	203		Union Nut (2 Req'd)
				71543	204	100	Thimble (2 Req'd)
				1635			1/4" Pipe Plug (2 Req'd)

INDEPENDENT PORTION

The Independent Portions, Pc. Nos. 32254 and 510839, are as covered on page 3 of the Catalog.

*NOTE A—For Spring Identification Table, see page 8.

NOTE B—If Malleable Iron Handles are desired, specify as follows:
 Piece No. 19204 Automatic Portion Handle, complete (Includes 10, 11 and 12)
 Piece No. 18754 Independent Portion Handle, complete (Includes 10, 11 and 12)

NOTE C—If repair Bush for Handles are desired, specify as follows:
 Piece No. 69167 Repair Bush for Handle for Automatic Valve.
 Piece No. 57359 Pin for Repair Bush for Handle.
 Piece No. 68596 Repair Bush for Handle for Independent Valve.

NOTE D—If repairs for old style Collapsible Equalizing Piston are desired, specify as follows:

Pc. No.	Description	Pc. No.	Description
29303	Collapsible Equalizing Piston, complete	66773	Rivet
66774	Rivet with Cotter (includes Pcs. 66772 and 66773)	*29353	Spring
66772	Cotter	85812	Piston Ring (2nd Repair)
29300	Valve		

†NOTE E—Unless otherwise specified second Repair Ring Pc. 85812 is furnished with Pc. No. 95172 (Piston with Ring). We are prepared to furnish gages for use in determining the correct size of ring to be applied to the bushing being refitted and we strongly recommend the use of these gages.

†NOTE F—Column headed "No. Per Pkg." indicates the items for which standard shipping packages have been established and the number contained in the package. Orders placed in these quantities and multiples thereof will facilitate shipments and provide convenient means for handling in store room stock.

Prices will be quoted upon application
 Orders should give PIECE NUMBER and NAME of part wanted

K-14 BRAKE VALVE

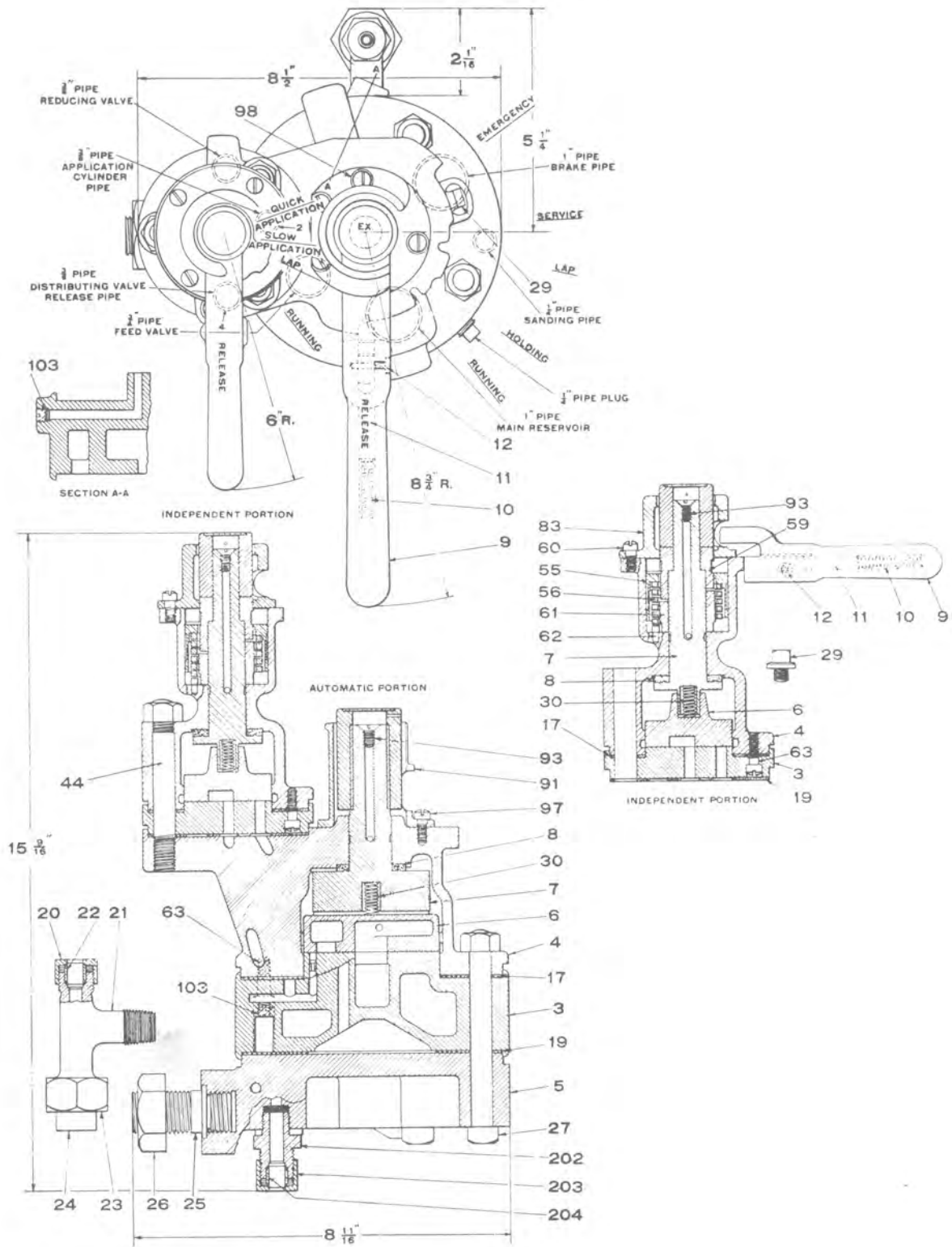

Approx. Net Weight 55 lbs.

K-14 BRAKE VALVE

The K-14 Brake Valve, Pc. 19261, involving the use of a separate Equalizing Piston Device, has been superseded by the K-14-A Brake Valve.

If major portions, such as the Automatic Portion or the Pipe Bracket, of the K-14 Brake Valve require replacement, arrangements should be made to substitute a new K-14-A Brake Valve or to convert the K-14 Brake Valve to the K-14-A type. Otherwise, repair parts for the K-14 Brake Valve are the same as listed on page 3, for the K-14-A Brake Valve, except omit the items of:

- Bottom Case, Pc. 86541 (Ref. Nos. 2 and 31)
- Middle Gasket, Pc. 86248 (Ref. No. 18)
- Equalizing Piston, complete, Pc. 95172 (including Ref. Nos. 32 to 38)

and substitute the following items for the corresponding ones in the Automatic Portion:

Pc. No.	Ref. No.	
86248	19	Lower Gasket
23371	27	Bolt and Nut (4 Req'd)

EQUALIZING PISTON DEVICE

The separate Equalizing Piston Device, Pc. No. 18720, has been used only with the K-14 Brake Valve, now superseded by the K-14-A Brake Valve, incorporating the Equalizing Piston.

If the Bottom Case or Pipe Bracket of the Equalizing Piston Device require replacement, arrangements should be made to substitute a K-14-A Brake Valve for the K-14 Brake Valve and separate Equalizing Piston Device. Other repair details are given below.

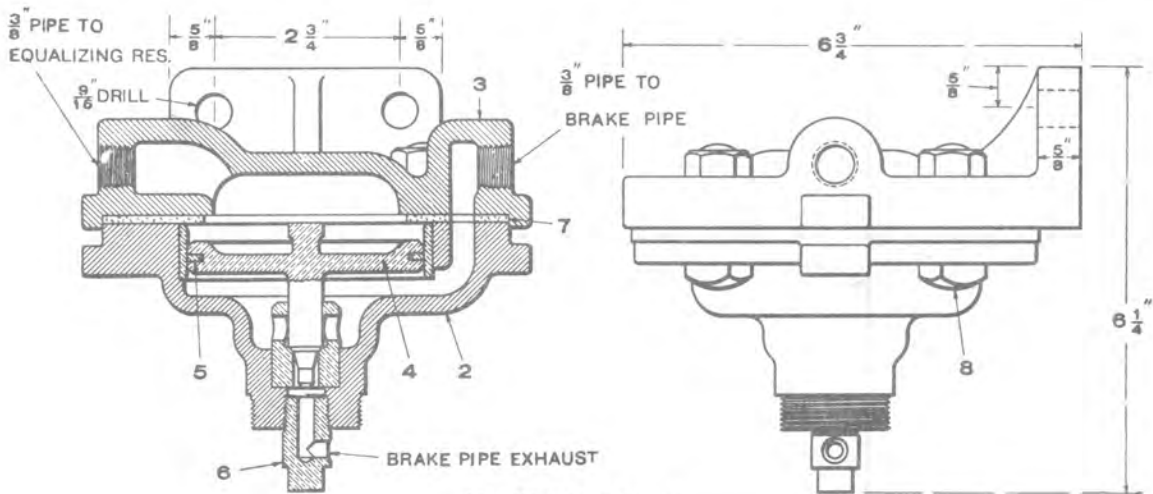

Net Weight 13 1/4 lbs.

Pc. No.	Ref. No.	
18722	4	Piston, complete, (Includes 5)
85812	5	Piston Packing Ring
14464	6	Exhaust Pipe Fitting

Pc. No.	Ref. No.	
18655	7	Gasket
11002	8	Bolt and Nut (4 Req'd)

Prices will be quoted upon application
 Orders should give PIECE NUMBER and NAME of part wanted

L-14-B (L-2) BRAKE VALVE
(With Non-Removable Handles)

Piece No. 84290 L-14-B Brake Valve, Complete, with Handles.

NOTE: The L-14-B Brake Valve is same as the K-14-B type except as covered below:

AUTOMATIC PORTION			INDEPENDENT PORTION		
Pc. No.	Ref. No.		Pc. No.	Ref. No.	
84291		Automatic Portion, with Pipe Bracket, Complete NOTE: Same as Pc. 67747 (Page 5) except substitute or add the following items; also omit items of Ref. Nos. 91, 93, 97, 98:	84292		Independent Portion, Complete NOTE: Same as Pc. 32254 (Page 5) except substitute or add the following items; also omit item of Ref. No. 93:
84289	7	Rotary Valve Key	17248	7	Rotary Valve Key
1993	9	Handle, Complete (includes 10, 11 and 12)	11966	9	Handle, Complete (includes 10, 11 and 12)
†1367	10	Handle Latch Spring	†9810	10	Handle Latch Spring
1996	11	Handle Latch	11932	11	Handle Latch
1368	12	Handle Latch Screw	1368	12	Handle Latch Screw
1992		Handle Nut	532103	83	Cover
1991		Handle Lock Nut	9926		Top Nut

SHEET METAL THREAD PROTECTORS

Sheet Metal thread protectors in the form of caps, plugs and discs are used to close the openings in various devices on shipment from our works, for the purpose of protecting threads from injury and preventing dirt from getting inside the apparatus. These are so satisfactory that we list below the protectors used with the K-14 type brake valves, believing that many railroads on account of the small expense involved and the protection insured, will desire to use them when shipping valves from point to point or when returning old valves to us for repairs.

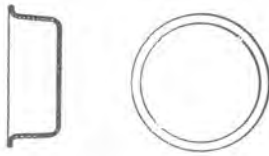

- Piece No. 21228. For 1/4" Pipe Tap
- Piece No. 21194. For 3/8" Pipe Tap
- Piece No. 21195. For 1/2" Pipe Tap
- Piece No. 21197. For 1" Pipe Tap

†SPRING IDENTIFICATION

The following table is shown to enable railroad men, storekeepers and all Air Brake men to identify the various springs used in the K-14 and L-14 type Brake Valves cataloged herein. It is based on calculated figures and the actual spring will vary somewhat, due to small differences in wire diameter, coil diameter, number of turns, etc. This tabulation is intended for identification only and should not be used for any other purpose. It does not represent a specification for the springs mentioned.

		SPRING IDENTIFICATION					
Piece No.	Out. Dia. "A"	Dia. Wire "B"	Free Height "C"	*Approx. No. Turns	Material	Name of Spring	Where Used
13109	1 1/2"	.057"	1 1/8"	9 1/2	Steel	Rotary Valve Spring	Automatic & Independent Portions
1367	3/2"	.057"	1 3/4"	15 1/2	Steel	Latch Spring	Automatic Portion
9810	3/2"	.0475"	1 1/2"	20	Steel	Latch Spring	Independent Portion
29353	3/2"	.068"	1 3/2"	8	Steel	Piston Spring	Automatic Portion
98165	3/2"	.040"	1 1/2"	9 1/2	Ph. Bz.	Piston Spring	Automatic Portion
17445	1 1/16"	3/32" Square	1 1/2"	6 1/2	Steel	Return Spring	Independent Portion

*NOTE—Number of turns for spring counted between extreme ends of the wire.

Prices will be quoted upon application
Orders should give **PIECE NUMBER** and **NAME** of part wanted



Westinghouse Air Brake Company

Air Brake Division

Wilmerding, Pa., U.S.A.



(D-24-B)

Feed Valves

Part Catalog No. 3209-2

June, 1954

(Superseding Issue of February, 1940 and
Part Catalog No. 3209-2, Sup. 3)



D-24-B FEED VALVE

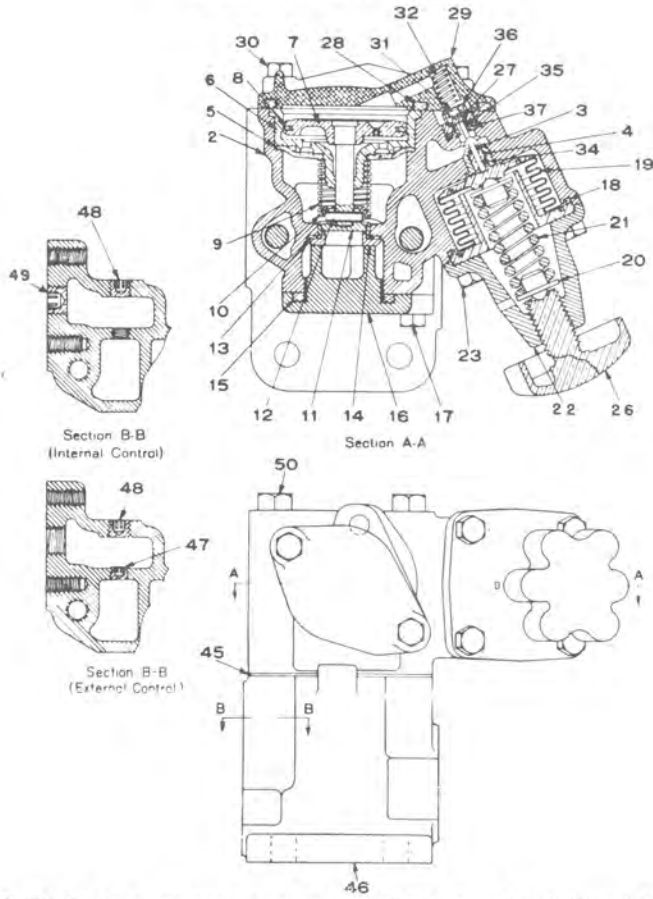

The D-24-B is now our recommended standard Feed Valve.

FEED VALVE		PIPE BRACKET			Approx. Net Weight
Complete	less Pipe Bracket	Pc. No.	Style	Remarks	
*538872	550016	538881	O-2 for Internal Control	Flanges for { 1 1/4" Supply 1" Delivery 3/8" Control	27 3/4 lbs.
*539099	550016	529969	O-2 for External Control	Flanges for { 1 1/4" Supply 1" Delivery 3/8" Control	27 3/4 lbs.
541172	550016	82260	D-1	Tapped for 3/4" Pipe	20 1/2 lbs.
542008	550016	542007	F-1	Tapped for 3/4" Pipe	21 1/2 lbs.
542011	550016	542010	H-1	Tapped for 3/4" Pipe	22 lbs.
540439	550016	538102	Offset Adapter	for B. V. Installation	19 lbs.
*547352	550016	549917	P-2	Flanges for { 3/4" Supply 3/4" Delivery 3/8" Control	24 lbs.
.....	550016	15 1/4 lbs.

*NOTE—The O-2 and P-2 Pipe Brackets have Flanges for WABCO TITE® or WABCO SEAL® Fittings but the Complete Pc. Nos. are less the Fittings. Any style of Fittings shown in Part Catalog 3216-21 or 3216-22 may be applied having Flanges suitable for the various sizes indicated in the schedule. These Catalogs also show the Gaskets and Cap Screws used in applying the Fittings.

Prices will be quoted upon application.

Orders should give PIECE NUMBER and NAME of part wanted.

D-24-B FEED VALVE

(for Complete Piece Numbers, see Page 2)

Pc. No.	Ref. No.		Pc. No.	Ref. No.	
537796	2	Body	7978	17	$\frac{3}{8}$ " x 1" Retainer Cover Cap Screw (2 Req'd.)
524609	3	$\frac{1}{4}$ " O.D. WABCO— Packing Ring	525846	18	Diaphragm Gasket
537800	4	Packing Ring Retaining Nut	525841	19	Bellows Diaphragm
525827	5	Supply Valve Strainer	525849	20	Regulating Spring Seat (2 Req'd.)
532156	6	Piston Bush	†91637	21	Regulating Spring
*527025		Piston and Ring, Complete (includes 7 and 8b)	549173	22	Diaphragm Cover
525824	7	Piston with Stem	7978	23	$\frac{3}{8}$ " x 1" Diaphragm Cover Cap Screw (4 Req'd.)
86829	8a	$2\frac{3}{4}$ " Piston Ring (1st Repair)	549172	26	Adjusting Handle
86830	8b	$2\frac{3}{4}$ " Piston Ring (2nd Repair)	537804	27	Regulating Valve
86831	8c	$2\frac{3}{4}$ " Piston Ring (3rd Repair)	525836	28	Cover Gasket
86832	8d	$2\frac{3}{4}$ " Piston Ring (4th Repair)	525837	29	Cover
†58444	9	Supply Valve Spring	7978	30	$\frac{3}{8}$ " x 1" Cover Cap Screw (4 Req'd.)
525828	10	Supply Valve Spring Seat	525839	31	Regulating Valve Spring Seat
525829	11	Supply Valve	†545764	32	Regulating Valve Spring
525830	12	Supply Valve Pin	537801	34	Regulating Valve Pusher Pin
525831	13	Supply Valve Seal	537802	35	Regulating Valve Seat
525832	14	Supply Valve Seat	537803	36	Regulating Valve Seat Retaining Nut
94790	15	Retainer Cover Gasket	541475	37	Regulating Valve Seat Gasket
525833	16	Supply Valve Seat Retainer Cover	†78000	45	Feed Valve Gasket

PIPE BRACKET

Pc. No.	Ref. No.		Pc. No.	Ref. No.	
538881	46	Pipe Bracket for Internal Control (includes 48 and 49) (for Pc. No. 538872)	538102	46	Offset Adapter for Brake Valve Installation (for Pc. No. 540439) (See Page 14)
529969	46	Pipe Bracket for External Control (includes 47 and 48) (for Pc. No. 539099)	549917	46	P-2 Pipe Bracket (for Pc. No. 547352) (See Page 14)
82260	46	D-1 Pipe Bracket (for Pc. No. 541172) (See Page 10)	515794	47	$\frac{1}{8}$ " Pipe Plug (for Pc. 529969)
542007	46	F-1 Pipe Bracket (for Pc. No. 542008) (See Page 10)	516298	48	$\frac{1}{4}$ " Pipe Plug
542010	46	H-1 Pipe Bracket (for Pc. No. 542011) (See Page 11)	56992	49	$\frac{3}{8}$ " Pipe Plug (for Pc. 538881)
			†19426	50	$\frac{1}{2}$ " x $4\frac{3}{4}$ " Feed Valve Cap Screw (2 Req'd.)

*Unless otherwise specified, the 2nd Repair Ring is included in Pc. 527025, Piston and Ring. We are prepared to furnish cylindrical gage, Pc. 524952, for determining the correct size of ring to be used in the bush being fitted. As an alternate, we have a set of four gages (packed in a neat metal box) identified by combination Pc. No. 88624.

†The Feed Valve Gasket, Pc. 78000 (Ref. 45) and the Feed Valve Cap Screw, Pc. 19426 (Ref. 50) are not a part of either Portion but of the Feed Valve and Pipe Bracket, Complete.

†For Spring Identification Table, see page 15.

FORMER STANDARD D-24-B FEED VALVE

Repair Details for the Former Standard D-24-B Feed Valve, Pc. 537402 are the same as those of Pc. 550016, except for Handle and Cover. If either of these details is required, order Pc. 540300 for the Cover and 540301 for the Handle. However, if it is desired to convert to the New Standard Design, Conversion Kit Pc. 550068 (Includes the new Cover and Handle) may be ordered.

D-24-A FEED VALVE

The D-24-A Feed Valve Pc. 525817 is obsolete and superseded by the D-24-B Feed Valve Pc. 550016. If the Body of the D-24-A Feed Valve is required, a complete new D-24-B Feed Valve must be ordered. If cover, Handle or Adjusting Stop need replacement, order Conversion Kit Pc. 550068 for new Cover and Handle. All other Repair Parts are the same as those listed for the D-24-B Feed Valve except:

Pc. No. 525835 Regulating Valve
 Pc. No. 525840 Regulating Valve Spring Cap Nut
 Pc. No. 3950 Adjusting Stop Screw (2 Req'd.)
 and the omission of Ref. Nos. 34, 35, 36 and 37.

Prices will be quoted upon application.

Orders should give PIECE NUMBER and NAME of part wanted.

M-3 SINGLE-PRESSURE FEED VALVE
(WITH D-1 PIPE BRACKET)

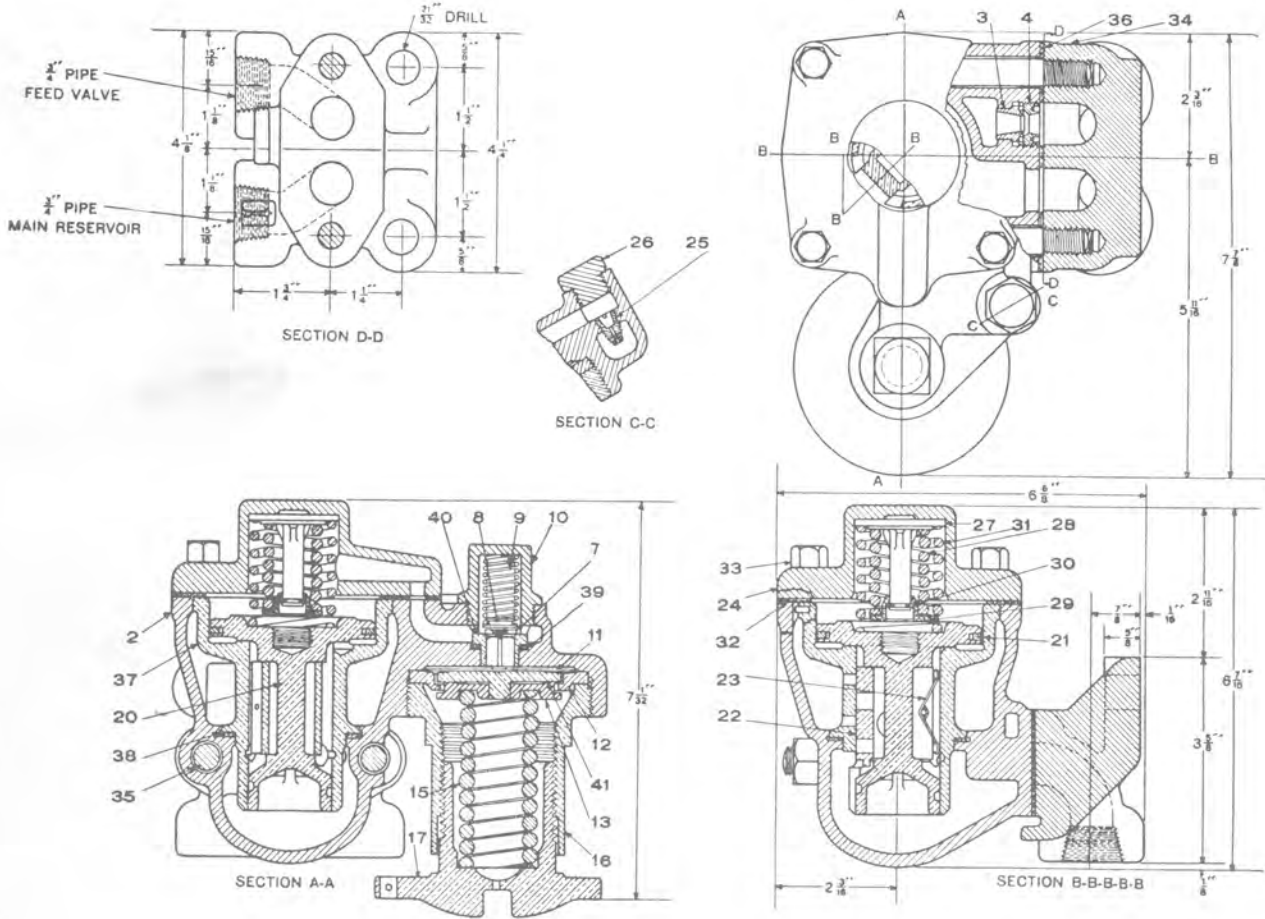

Net Weight 26 lbs.

M-3 SINGLE-PRESSURE FEED VALVE

The M-3 Feed Valve is regularly furnished with the D-1 Pipe Bracket unless otherwise specified.

- Piece No. 84483 M-3 Single-Pressure Feed Valve, with "D-1" Pipe Bracket, complete
 Piece No. 84432 M-3 Single-Pressure Feed Valve, with "F-1" Pipe Bracket, complete
 Piece No. 84433 M-3 Single-Pressure Feed Valve, with "H-1" Pipe Bracket, complete
 Piece No. 84208 M-3 Single-Pressure Feed Valve, complete, less Pipe Bracket and Gasket

Pc. No.	Ref. No.		Pc. No.	Ref. No.	
91568	2	Body, Complete (Includes 3, 4, 25, Pc. 80614, 4 of 33a and 33b)	81276	24	Cover
77970	3	Bush for $\frac{5}{16}$ " Venturi Tube Fitting	91025	25	$\frac{1}{8}$ " Choke Plug with $\frac{3}{64}$ " Drill
77971	4	Nut for $\frac{5}{16}$ " Venturi Tube Fitting	77989	26	By-Pass Choke Cap Nut
77973	7	Regulating Valve	77990	27	Piston Spring Stem
77974	8	Regulating Valve Spring Tip	*77991	28	Inner Piston Spring
*78755	9	Regulating Valve Spring	77992	29	Spring Collar
80360	10	Regulating Valve Cap Nut	77993	30	Spring Collar Retainer
73901	11	Diaphragm (2 Req'd.)	*77994	31	Outer Piston Spring
81271	12	Diaphragm Ring	81006	32	Cover Gasket
81273	13	Regulating Spring Seat	37117	33a	$\frac{3}{8}$ " x $1\frac{3}{8}$ " Stud (4 Req'd.)
*73891	15	Regulating Spring	2220	33b	Nut (4 Req'd.)
81274	16	Regulating Spring Box	82260	34	D-1 Pipe Bracket (See Page 11)
84203	17	Regulating Nut	542007	34	F-1 Pipe Bracket (See Page 11)
†82315		Piston with Ring (Includes 20 and 21b)	542010	34	H-1 Pipe Bracket (See Page 12)
80664	20	Piston, Less Ring	78000	36	Pipe Bracket Gasket
87007	21a	Piston Ring (1st Repair)	80666		Cage Bush with Piston and Slide Valve, complete, (Includes 20, 21a, 22, 23 and 37)
87008	21b	Piston Ring (2nd Repair)	81840	37	Cage Bush
87009	21c	Piston Ring (3rd Repair)	81012	38	Cage Bush Seal
87010	21d	Piston Ring (4th Repair)	81013	39	Regulating Valve Bush Seal
77985	22	Slide Valve	80667	40	Regulating Valve Bush
12573	23	Slide Valve Spring	81272	41	Diaphragm Follower

*NOTE A—For Spring Identification Table, see page 15.

NOTE B—If desired the M-3 Single-Pressure Feed Valve may be converted into an M-3-A Double-Pressure Feed Valve by the addition of the following parts:

2	Adjustable Stops	Pc. No. 79220
2	Fil. Hd. Cap Screws	Pc. No. 2325
1	Stop Pin	Pc. No. 81278
1	Stop Pin Rivet	Pc. No. 10068

†NOTE C—Unless otherwise specified, the 2nd Repair Ring is included in Pc. 82315, Piston and Ring. We are prepared to furnish cylindrical gage, Pc. 532808, for determining the correct size of ring to be used in the bush being fitted. As an alternate, we have a set of four gages (packed in a neat metal box) identified by combination Pc. No. 88626.

Prices will be quoted upon application
 Orders should give **PIECE NUMBER** and **NAME** of part wanted

M-3-A DOUBLE-PRESSURE FEED VALVE
(WITH D-1 PIPE BRACKET)

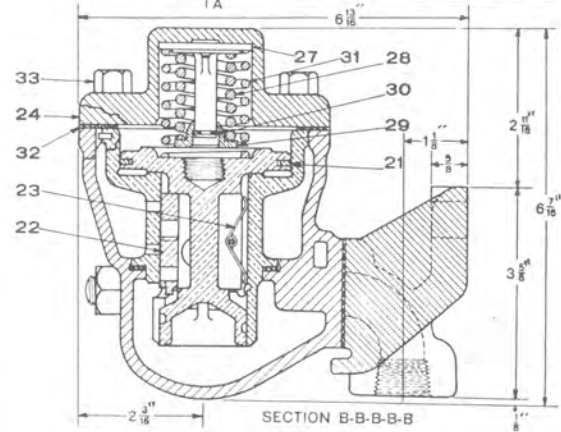
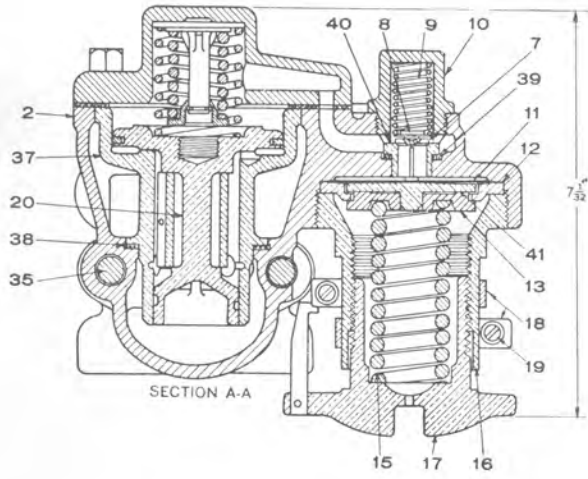
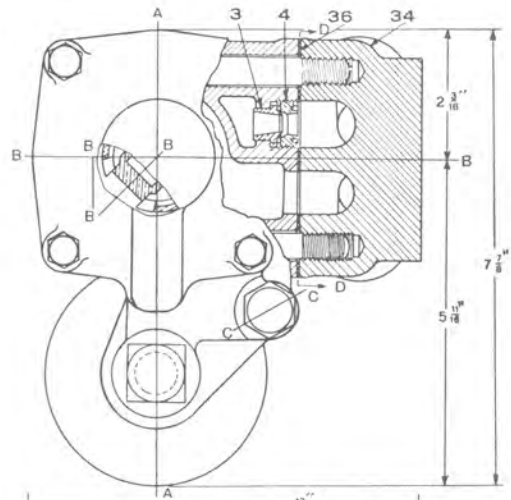
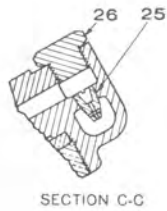
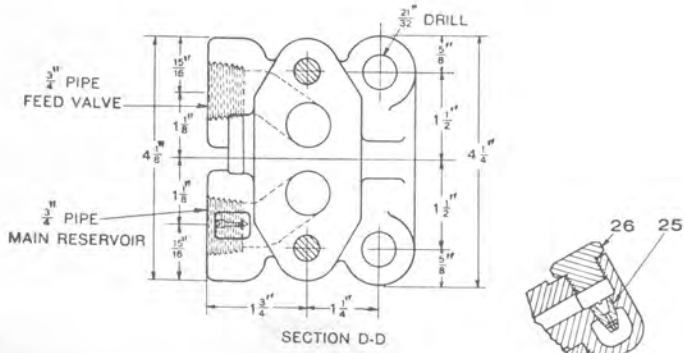

Net Weight 26 lbs.

M-3-A DOUBLE-PRESSURE FEED VALVE

The M-3-A Feed Valve is regularly furnished with the D-1 Pipe Bracket unless otherwise specified.

- Piece No. 84304 M-3-A Double-Pressure Feed Valve, with "D-1" Pipe Bracket, complete
- Piece No. 84192 M-3-A Double-Pressure Feed Valve, with "F-1" Pipe Bracket, complete
- Piece No. 84191 M-3-A Double-Pressure Feed Valve, with "H-1" Pipe Bracket, complete
- Piece No. 84207 M-3-A Double-Pressure Feed Valve, complete, less Pipe Bracket and Gasket

Pc. No.	Ref. No.		Pc. No.	Ref. No.	
91568	2	Body, Complete (Includes 3, 4, 25, Pc. 80614, 4 of 33a and 33b)	77985	22	Slide Valve
77970	3	Bush for $\frac{3}{16}$ " Venturi Tube Fitting	12573	23	Slide Valve Spring
77971	4	Nut for $\frac{3}{16}$ " Venturi Tube Fitting	81276	24	Cover
77973	7	Regulating Valve	91025	25	$\frac{1}{8}$ " Choke Plug with $\frac{3}{64}$ " Drill
77974	8	Regulating Valve Spring Tip	77989	26	By-Pass Choke Cap Nut
*78755	9	Regulating Valve Spring	77990	27	Piston Spring Stem
80360	10	Regulating Valve Cap Nut	*77991	28	Inner Piston Spring
73901	11	Diaphragm (2 Req'd.)	77992	29	Spring Collar
81271	12	Diaphragm Ring	77993	30	Spring Collar Retainer
81273	13	Regulating Spring Seat	*77994	31	Outer Collar Spring
*73891	15	Regulating Spring	81006	32	Cover Gasket
81274	16	Regulating Spring Box	37117	33a	$\frac{3}{8}$ "x1 $\frac{3}{8}$ " Stud (4 Req'd.)
84209	17	Regulating Nut, complete	2220	33b	Nut (4 Req'd.)
79220	18	Adjustable Stop (2 Req'd.)	82260	34	D-1 Pipe Bracket (See Page 11)
2325	19	$\frac{1}{4}$ "-20x $\frac{1}{2}$ " Fil. Hd. Cap Screw (2 Req'd.)	542007	34	F-1 Pipe Bracket (See Page 11)
82315		Piston with Ring (Includes 20 and 21b)	542010	34	H-1 Pipe Bracket (See Page 12)
80664	20	Piston, less Ring	78000	36	Pipe Bracket Gasket
87007	21a	Piston Ring (1st Repair)	80666		Cage Bush with Piston and Slide Valve, complete, (Includes 20, 21a, 22, 23 and 37)
87008	21b	Piston Ring (2nd Repair)	81840	37	Cage Bush
87009	21c	Piston Ring (3rd Repair)	81012	38	Cage Bush Seal
87010	21d	Piston Ring (4th Repair)	81013	39	Regulating Valve Bush Seal
			80667	40	Regulating Valve Bush
			81272	41	Diaphragm Follower

*NOTE A—For Spring Identification Table, see page 15.

NOTE B—Unless otherwise specified, the 2nd Repair Ring is included in Pc. 82315, Piston and Ring. We are prepared to furnish cylindrical gage, Pc. 532808, for determining the correct size of ring to be used in the bush being fitted. As an alternate, we have a set of four gages (packed in a neat metal box) identified by combination Pc. No. 88626.

Prices will be quoted upon application
Orders should give PIECE NUMBER and NAME of part wanted

C-6 SINGLE-PRESSURE FEED VALVE

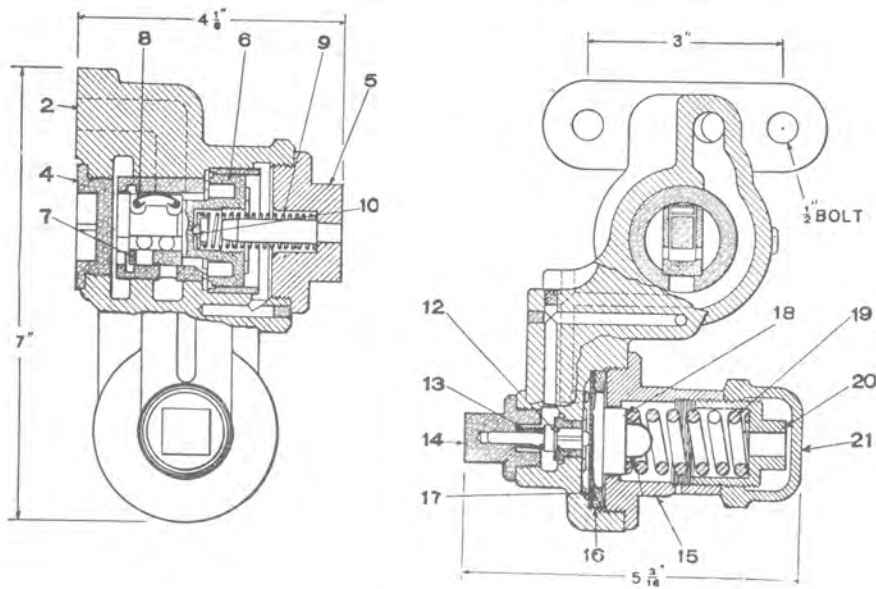

Net Weight 10 lbs.

This Feed Valve is furnished only when specially ordered.

- Piece No. 18481 C-6 Single-Pressure Feed Valve with "F" (crossed passage) Pipe Bracket and Gasket, complete (See Note A).
- Piece No. 18482 C-6 Single-Pressure Feed Valve with "H" (direct passage) Pipe Bracket and Gasket, complete (See Note A).
- Piece No. 51405 C-6 Single-Pressure Feed Valve with "J" Pipe Bracket and Gasket, complete (See Note A).
- Piece No. 18480 C-6 Single-Pressure Feed Valve, complete, without Pipe Bracket or Gasket

Pc. No.	Ref. No.	
18460	2	Valve Body, bushed
18458	4	Flush Nut
79183	5	Cap Nut
18454	6	Piston
18455	7	Supply Valve
1411	8	Supply Valve Spring
*18286	9	Piston Spring
3054	10	Piston Spring Tip
16183	12	Regulating Valve

Pc. No.	Ref. No.	
* 1060	13	Regulating Valve Spring
6509	14	Regulating Valve Cap Nut
1062	15	Spring Box
1064*	16	Diaphragm Ring
1063	17	Diaphragm (2 Req'd)
1065	18	Diaphragm Spindle
*40452	19	Regulating Spring
11261	20	Regulating Nut
1067	21	Check Nut

NOTE A—For Pipe Brackets, Gasket and additional information, see pages 12, 13 and 15.

NOTE B—Old Type B-3 Feed Valve—Repair parts are the same as above shown except as follows:

Pc. No.	Ref. No.	
1046	2	Valve Body, bushed
1051	4	Flush Nut
17353	6	Piston

Pc. No.	Ref. No.	
1054	7	Supply Valve
* 1057	9	Piston Spring
1058	12	Regulating Valve

*NOTE C—For Spring Identification Table, see page 15.

Prices will be quoted upon application

Orders should give PIECE NUMBER and NAME of part wanted

B-6 DOUBLE-PRESSURE FEED VALVE

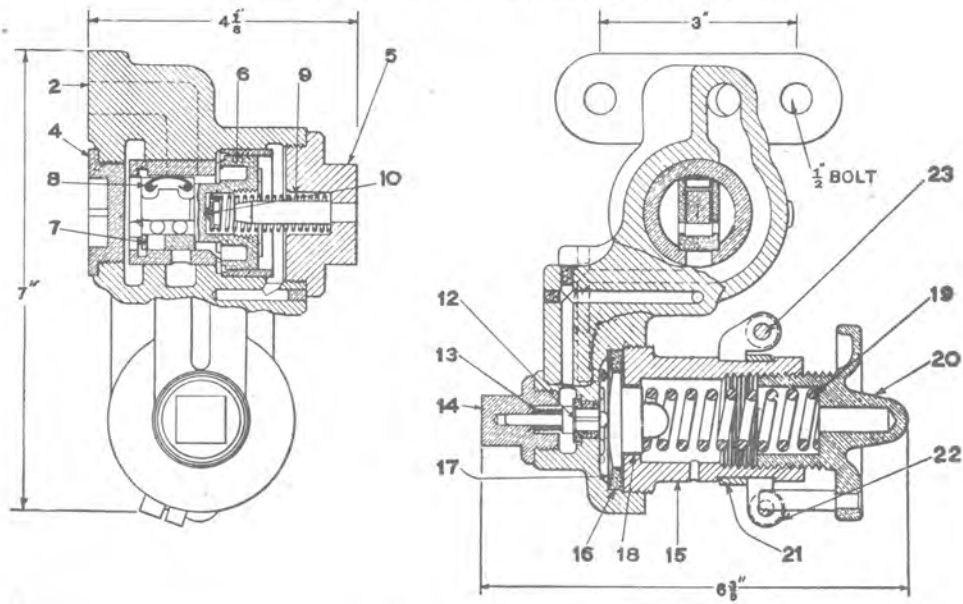

Net Weight 10 $\frac{1}{2}$ lbs.

This Feed Valve is furnished only when specially ordered.

- Piece No. 18478 B-6 Double-Pressure Feed Valve with "F" (crossed passage) Pipe Bracket and Gasket, complete (See Note A).
- Piece No. 18479 B-6 Double-Pressure Feed Valve with "H" (direct passage) Pipe Bracket and Gasket, complete (See Note A).
- Piece No. 51404 B-6 Double-Pressure Feed Valve with "J" Pipe Bracket and Gasket, complete (See Note A).
- Piece No. 18477 B-6 Double-Pressure Feed Valve, complete without Pipe Bracket or Gasket

Pc. No.	Ref. No.	
18460	2	Valve Body, bushed
18458	4	Flush Nut
79183	5	Cap Nut
18454	6	Piston
18455	7	Supply Valve
1411	8	Supply Valve Spring
*18286	9	Piston Spring
3054	10	Piston Spring Tip
16183	12	Regulating Valve
* 1060	13	Regulating Valve Spring
6509	14	Regulating Valve Cap Nut

Pc. No.	Ref. No.	
13241	15	Spring Box
1064	16	Diaphragm Ring
1063	17	Diaphragm (2 Req'd)
1065	18	Diaphragm Spindle
*40451	19	Regulating Spring
13259	20	Regulating Hand Wheel
13858	21	Inner Hand Wheel Stop (Includes 23)
13859	22	Outer Hand Wheel Stop (Includes 23)
12304	23	Stop Screw (2 Req'd)

NOTE A—For Pipe Brackets, Gasket and additional information, see pages 12, 13 and 15.

NOTE B—Old Type B-4 Feed Valve—Repair parts are the same as above shown except as follows:

Pc. No.	Ref. No.	
1046	2	Valve Body, bushed
1051	4	Flush Nut
17353	6	Piston

Pc. No.	Ref. No.	
1054	7	Supply Valve
* 1057	9	Piston Spring
1058	12	Regulating Valve

*NOTE C—For Spring Identification Table, see page 15.

Prices will be quoted upon application

Orders should give PIECE NUMBER and NAME of part wanted

D-1 PIPE BRACKET

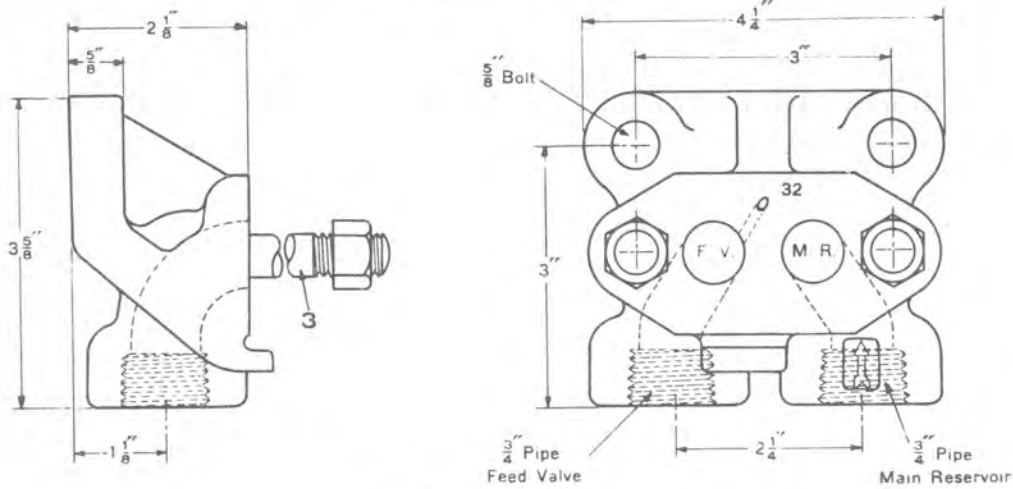
Net Weight 4 $\frac{3}{4}$ lbs.

This Pipe Bracket is for use with the D-24-B, M-3 and M-3-A Feed Valves. It is regularly furnished, unless otherwise specified, with the M-3 and M-3-A Feed Valves.

Pc. No.	Ref. No.	Description
82260		D-1 Pipe Bracket, complete
33864	3a	Stud (2 Req'd)
10829	3b	Nut (2 Req'd)

F-1 PIPE BRACKET

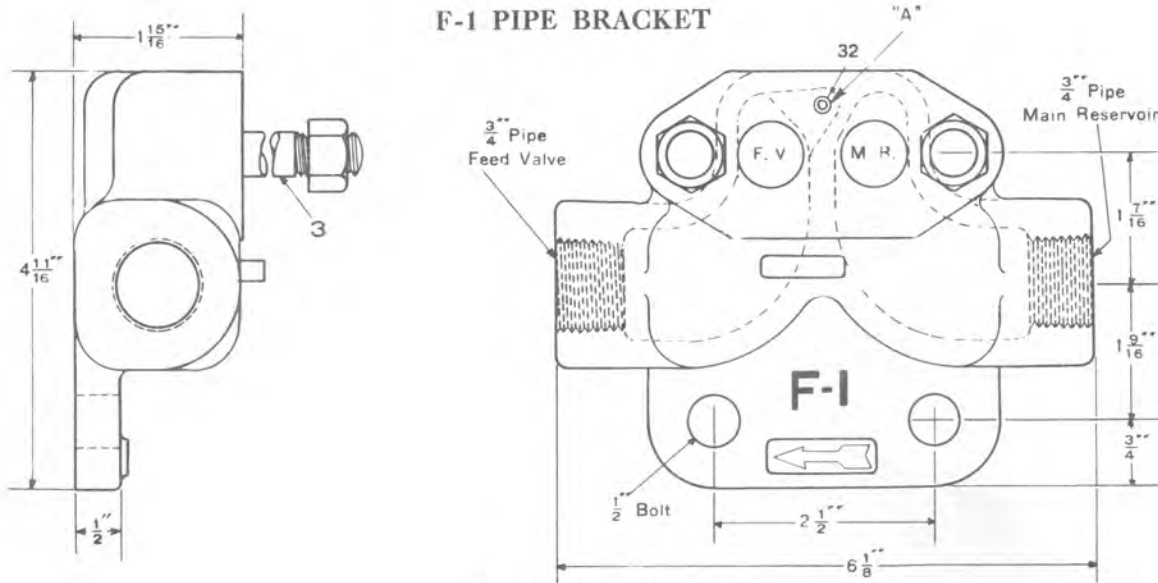

Net Weight 6 lbs.

This Pipe Bracket is for use with the D-24-B (Internal Control), M-3 and M-3-A Feed Valves and is designed to replace the "F" Pipe Bracket without change in piping when substituting one of these Feed Valves for the C-6 or B-6.

Pc. No.	Ref. No.	Description
542007		F-1 Pipe Bracket, complete
33864	3a	Stud (2 Req'd)
10829	3b	Nut (2 Req'd)

Prices will be quoted upon application

Orders should give PIECE NUMBER and NAME of part wanted

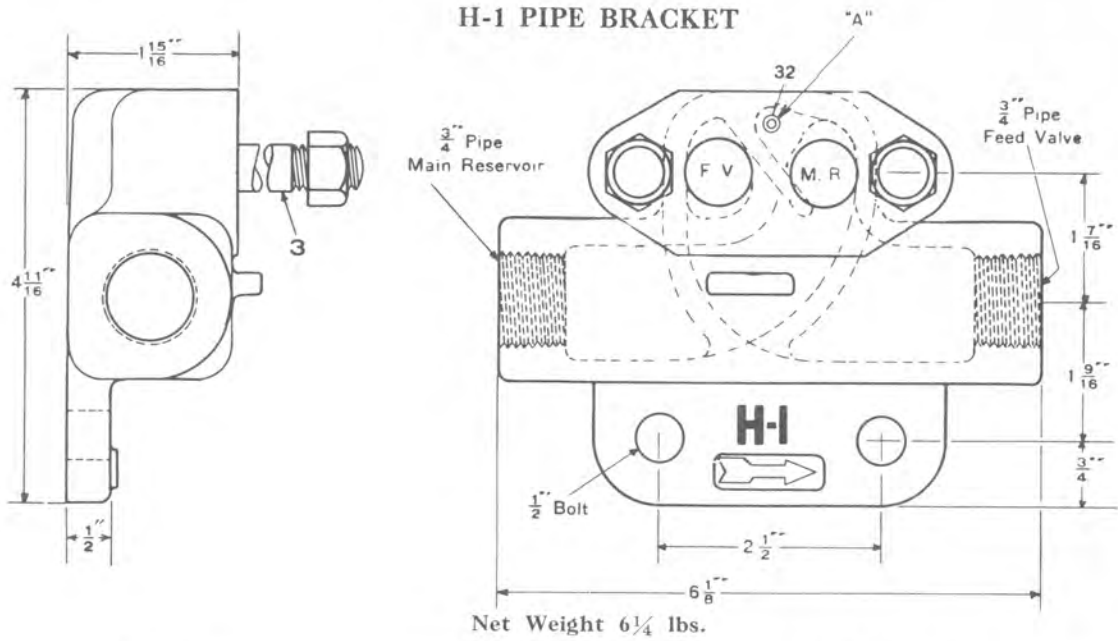

This Pipe Bracket is for use with the D-24-B (Internal Control), M-3 and M-3-A Feed Valves and is designed to replace the "H" Pipe Bracket without change in piping when substituting one of these Feed Valves for the C-6 or B-6.

Pc. No.	Ref. No.	Description
542010		H-1 Pipe Bracket, complete
33864	3a	Stud (2 Req'd)
10829	3b	Nut (2 Req'd)

"F" (CROSSED PASSAGE) PIPE BRACKET

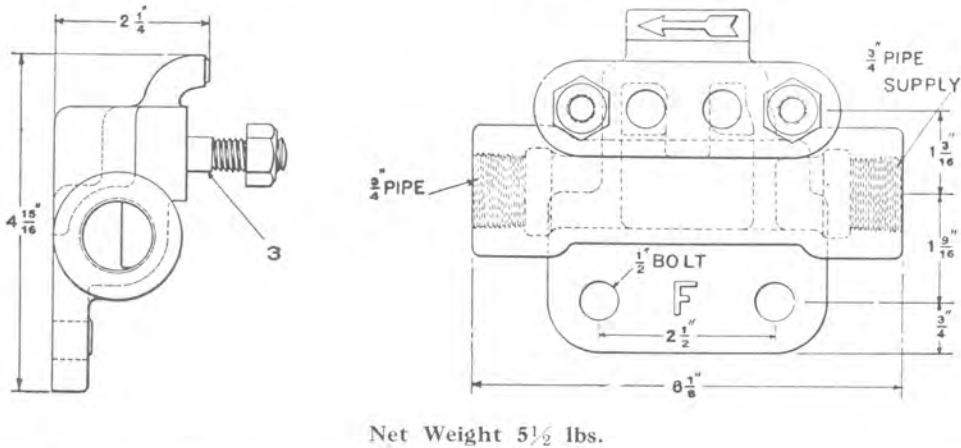

Pipe Bracket for C-6 and B-6 Feed Valves.

Pc. No.	Ref. No.	Description
18240		"F" (Crossed passage) Pipe Bracket, complete
35384	3a	Stud (2 Req'd)
1012	3b	Nut (2 Req'd)

Prices will be quoted upon application
Orders should give PIECE NUMBER and NAME of part wanted

"H" (DIRECT PASSAGE) PIPE BRACKET

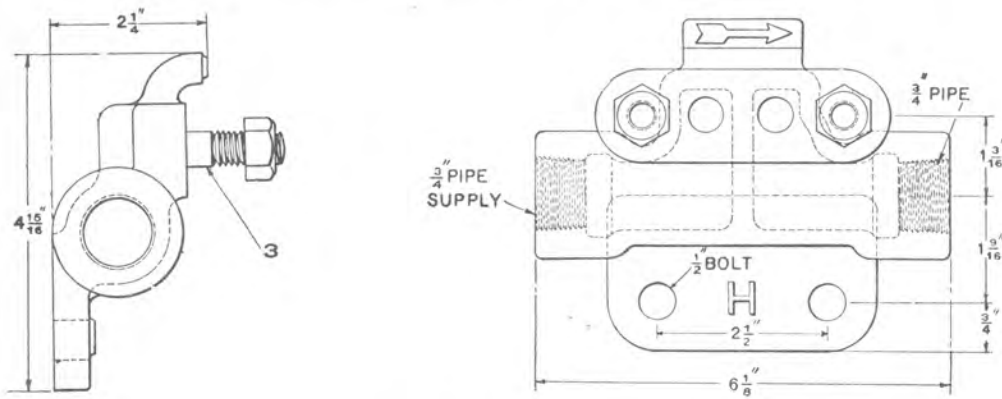

Net Weight 5 lbs.

Pipe Bracket for C-6 and B-6 Feed Valves.

Pc. No.	Ref. No.	Description
18463		"H" (direct passage) Pipe Bracket, complete
35384	3a	Stud (2 Req'd)
1012	3b	Nut (2 Req'd)

"J" PIPE BRACKET

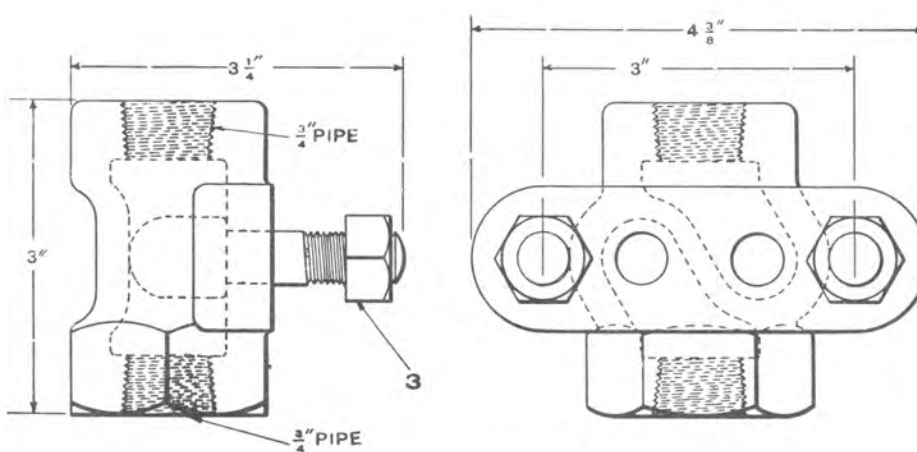

Net Weight 2 1/2 lbs.

Pipe Bracket for C-6 and B-6 Feed Valves, designed to enable installation of the Feed Valve in a Vertical Pipe, when desired.

Pc. No.	Ref. No.	Description
41811		"J" Pipe Bracket, complete
35384	3a	Stud (2 Req'd)
1012	3b	Nut (2 Req'd)

Prices will be quoted upon application
Orders should give PIECE NUMBER and NAME of part wanted

UNIVERSAL PIPE BRACKET

CROSSED PASSAGE

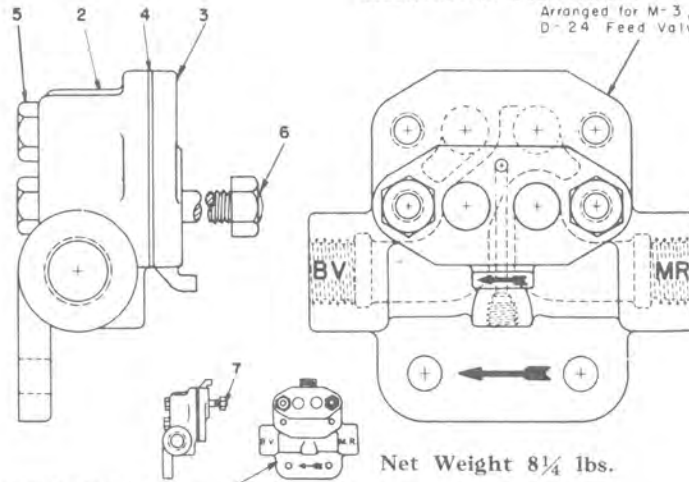
Arranged for M-3, M-3-A and
D-24 Feed ValvesArranged for C-6, B-6, J-1, J-2
and F Feed Valves

Piece No. 548641 Universal Pipe Bracket, Complete (Crossed Passage)

Piece No. 549891 Universal Pipe Bracket, Complete (Direct Passage)

Pc. No.	Ref. No.	Description
548643	2	Pipe Bracket (for Complete Pc. 548641)
549892	2	Pipe Bracket (for Complete Pc. 549891)
548644	3	Pipe Bracket Adapter Plate
90594	4	Bracket Adapter Plate Gasket
25428	5	1/2" x 2 1/8" Bracket Adapter Plate Screw (2 Req'd)
514859	6a	1/2" x 6 3/4" Hex Hd. Cap Screw (2 Req'd) (Used with M-3, M-3-A and D-24-B Feed Valves)
10829	6b	1/2" Hex Nut (2 Req'd)
24542	7a	1/2" x 3 1/2" Hex Hd. Cap Screw (2 Req'd) (Used with C-6 and B-6 Feed Valves)
10829	7b	1/2" Hex Nut (2 Req'd)

DIRECT PASSAGE

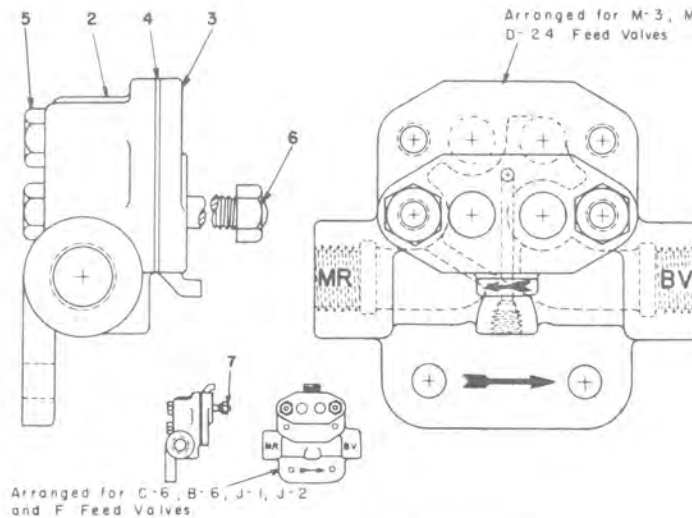
Arranged for M-3, M-3-A and
D-24 Feed ValvesArranged for C-6, B-6, J-1, J-2
and F Feed Valves

Net Weight 8 1/4 lbs.

Prices will be quoted upon application

Orders should give PIECE NUMBER and NAME of part wanted

P-2 PIPE BRACKET

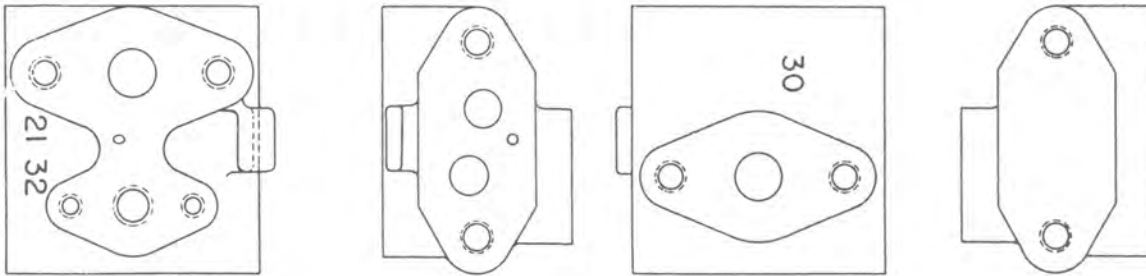

Pc. No.

549917

P-2 Pipe Bracket

19426

$\frac{1}{2}$ " x $4\frac{3}{4}$ " Cap Screw (2 Req'd) (for securing Feed Valve to Pipe Bracket)
(must be ordered separately)

The P-2 Pipe Bracket has Flanges for WABCOTITE® or WABCOSEAL® Fittings. ($\frac{3}{4}$ " Flange for Feed Valve and Supply, $\frac{3}{8}$ " for Control). Any Style of Fittings of proper size Flanges as shown in Part Catalogs 3216-21 and 3216-22 may be applied. These Catalogs also show the Gaskets and Cap Screws used in applying the Fittings.

ANGLE OFFSET ADAPTER

This Adapter is used for mounting the D-24-B Feed Valve on the D-24 Brake Valve only when the clearance for installing the D-24 Brake Valve is insufficient for Normal Application of the Feed Valve.

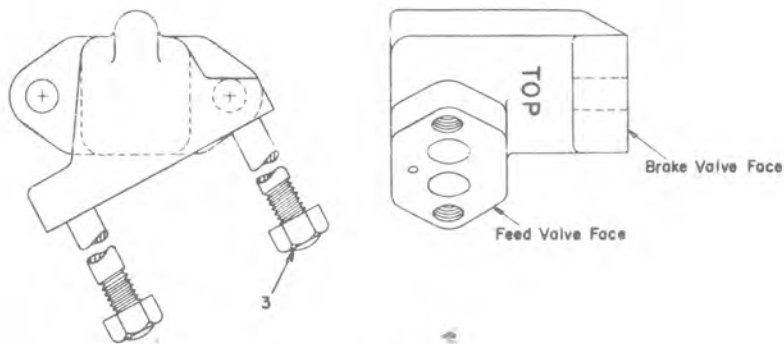

Pc. No. Ref. No.

538102

Angle Offset Adapter, Complete

33864

3a

 $\frac{1}{2}$ " x $5\frac{1}{4}$ " Stud (2 Req'd)

10829

3b

 $\frac{1}{2}$ " Hex Nut (2 Req'd)

Prices will be quoted upon application

Orders should give PIECE NUMBER and NAME of part wanted

GASKETS

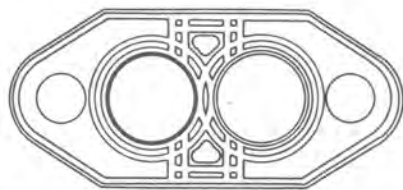

(For use with D-24-B, M-3 and M-3-A Feed Valves)
 Piece No. 78000 Feed Valve Gasket

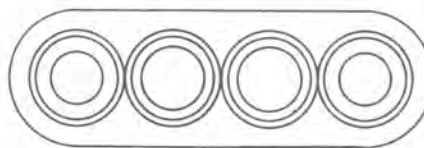

(For use with C-6 and B-6 Feed Valves)
 Piece No. 75345 Feed Valve Gasket

SHEET METAL THREAD PROTECTORS

Sheet Metal protectors in the form of caps, plugs and discs are used to close the openings in various devices, on shipment from our works, for the purpose of protecting threads from injury and preventing dirt from getting inside the apparatus. These are so satisfactory that we list below the protectors used with Feed Valves, believing that many railroads, on account of the small expense involved and the protection insured, will desire to use them when shipping valves from point to point, or when returning old valves to us for repairs.



Piece No. 21195 For 1/2" Pipe Tap

Piece No. 21196 For 3/4" Pipe Tap

Piece No. 27370 For Pipe Bracket Face of Feed Valves

SPRING IDENTIFICATION

The following table is shown to enable railroad men, storekeepers and all Air Brake men to identify the various springs used in the Feed Valves cataloged herein. It is based on calculated figures and the actual spring will vary somewhat, due to small differences in wire diameter, coil diameter, number of turns, etc. This tabulation is intended for identification only and should not be used for any other purpose. It does not represent a specification for the springs mentioned.

Pc. No.	Approx. Out. Dia. "A"	Approx. Dia. Wire "B"	Approx. Free Height "C"	*Approx. No. Turns	Material	SPRING IDENTIFICATION	
						Name of Spring	Where Used
58444	1 1/4"	.092"	3 1/2"	11	Steel	Supply V. Spring	D-24-B Feed Valve
91637	1"	.220"	2 3/4"	9 1/2	Steel	Regulating Spring	D-24-B Feed Valve
545764	3/8"	.054"	1 11/32"	13	Steel	Regulating V. Spr.	D-24-B Feed Valve
78755	43/64"	3/32"	1 13/16"	10 1/2	Steel	Reg. Valve Spring	M-3 and M-3-A Feed Valves
73891	1 13/32"	.281"	3 25/32"	10	Steel	Regulating Spring	M-3 and M-3-A Feed Valves
77991	1.067"	.192"	1.15"	6	Steel	Inner Piston Spring	M-3 and M-3-A Feed Valves
77994	1 9/16"	.1563"	2.035"	5	Steel	Outer Piston Spring	M-3 and M-3-A Feed Valves
1057	9/16"	.058"	2 3/4"	15 1/2	Steel	Supply Valve Piston Spring	B-3, B-4 Feed Valves
1060	5/16"	.045"	3 9/64"	7 1/2	Ph. Bz.	Regulating Valve Spring	C-6, B-6 Feed Valves
18286	1 9/32"	.072"	2 21/32"	14 1/2	Steel	Piston Spring	C-6, B-6 Feed Valves
40451	1"	.22"	2 3/4"	9	Steel	Regulating Spring	B-6 Feed Valves
40452	1"	.22"	2"	6 1/2	Steel	Regulating Spring	C-6 Feed Valves

*NOTE Number of turns for each spring counted between the extreme ends of the wire.

Prices will be quoted upon application

Orders should give PIECE NUMBER and NAME of part wanted

Westinghouse Air Brake Company

Air Brake Division

Wilmerding, Pa., U. S. A.

OFFICES

ATLANTA 3	Candler Building
BOSTON 16	Statler Building
CHICAGO 4	Railway Exchange Building
CLEVELAND 15	Midland Building
DENVER 2	Denver National Building
HOUSTON 2, TEX.	Commerce Building
LOS ANGELES 14	Pacific Electric Building
MEXICO, D. F., MEXICO	Edificio Aztlan
NEW YORK 1	Empire State Building
ST. LOUIS 3	Shell Building
ST. PAUL 1	First National Bank Building
SAN FRANCISCO 5	Matson Building
SEATTLE 1	Securities Building
WASHINGTON 6, D. C.	Ring Building

NO. 6 KR and 6 IKR DISTRIBUTING VALVES

Parts Catalog No. 3212-2, Sup. 6

August, 1953

Reprinted, March, 1956

(Superseding Issue of August, 1944 and Temporary Catalogs No.
3212-2, Sup. 6A and 3212-2, Sup. 6B)

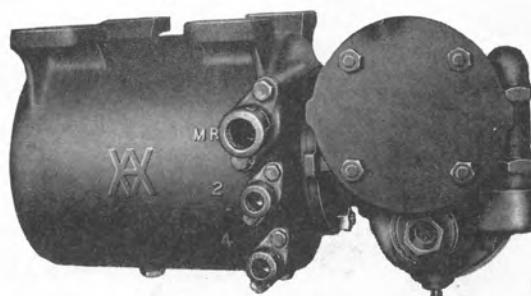
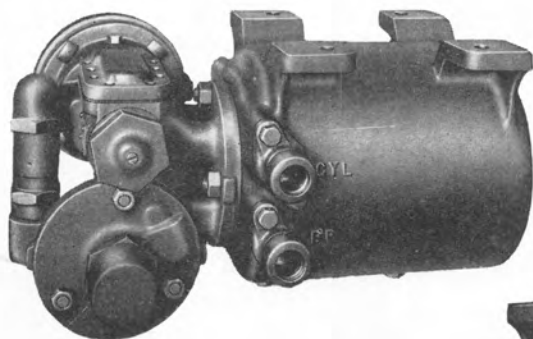

Westinghouse Air Brake COMPANY

AIR BRAKE DIVISION  WILMERDING, PA.

No. 6-KR DISTRIBUTING VALVE

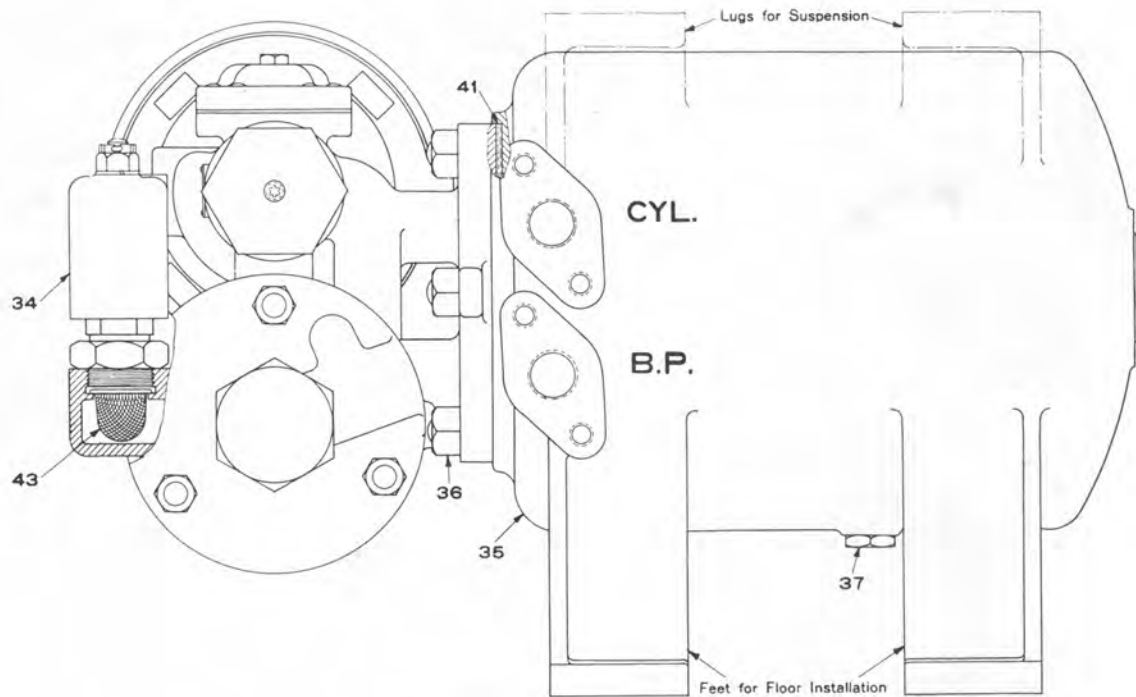
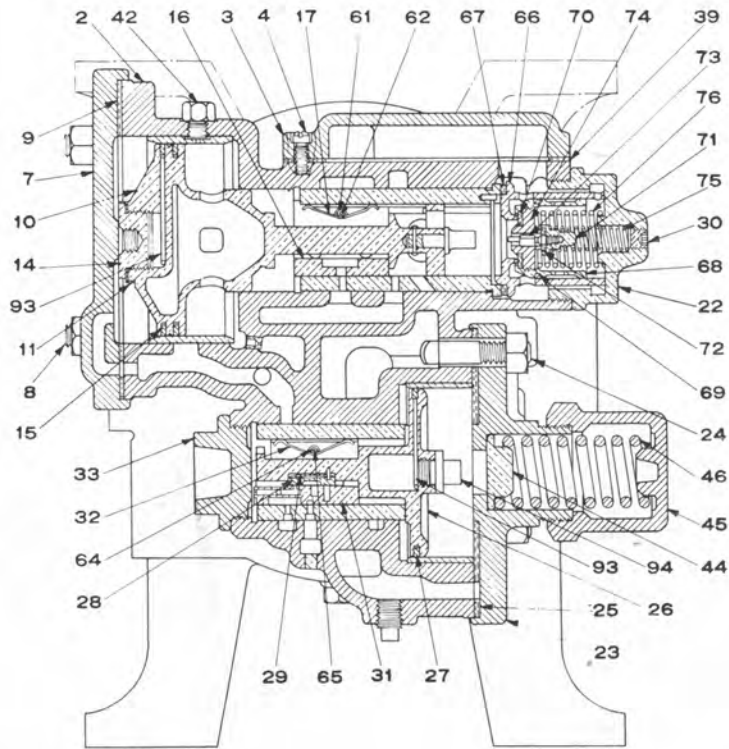

Approx. Net Weight 170 Lbs.

No. 6-KR DISTRIBUTING VALVE

Distributing Valve Complete With Safety Valve Less Fittings†	Valve Portion		Reservoir	
	Complete	Less Safety Valve	Complete Pc. No.	Mounting
542842	542922	542528	511752	Suspension Floor
542843	542922	542528	514292	

Piece No.	Ref. No.	† No. Per Pkg.	Description	Piece No.	Ref. No.	† No. Per Pkg.	Description
542521	2		Distributing Valve Body (includes 42 and two of Pc. 1635)	501460	22		Application Valve Nut (includes 30)
96247	3		Blanking Cover	540796			Cylinder Cap, Complete (includes 23, 44, 45 and 46)
518711	4		.242" x 1/16" Blanking Cover Screw (10 Req'd.)	69659	23		Cylinder Cap
71487	7		Application Cylinder Cover	10836	24	50	1/2" x 1 7/8" Cylinder Cap Bolt and Nut (3 Req'd)
10836	8	50	1/2" x 1 7/8" Application Cylinder Cover Bolt and Nut (4 Req'd)	80043	25		Cylinder Cap Gasket
70630	9		Application Cylinder Cover Gasket	*543201	1		Equalizing Piston, Complete, with Ring (includes 26 and 27b) (See Note B)
*543259			Application Piston, Complete, with Rings (includes 10 and two of 15b) (See Note B)	540749	26	1	Equalizing Piston, Complete, less Ring (includes 93 and 94)
540745	10	1	Application Piston, Complete, less Rings (includes 11, 14 and 93)	85811	27a	50	3 1/2" Equalizing Piston Ring (1st Repair)
506611	11		Lock Washer	85812	27b	50	3 1/2" Equalizing Piston Ring (2nd Repair)
540744	14		Piston Cap Nut	85813	27c	50	3 1/2" Equalizing Piston Ring (3rd Repair)
87017	15a	50	4" Application Piston Ring (1st Repair) (2 Req'd)	85814	27d	50	3 1/2" Equalizing Piston Ring (4th Repair)
87018	15b	50	4" Application Piston Ring (2nd Repair) (2 Req'd)	94964	28		Equalizing Graduating Valve
87019	15c	50	4" Application Piston Ring (3rd Repair) (2 Req'd)	12887	29		Equalizing Graduating Valve Spring
87020	15d	50	4" Application Piston Ring (4th Repair) (2 Req'd)	515794	30		1/8" Pipe Plug
96249	16	4	Exhaust Slide Valve	80825	31	12	Equalizing Slide Valve
93946	17		Exhaust Slide Valve Spring	12573	32	200	Equalizing Slide Valve Spring
				18602	33		Lower Cap Nut

*NOTE A—Unless otherwise specified, the 2nd Repair Ring is furnished with all combinations of Piston with Ring. We are prepared to furnish Cylindrical Gages for use in determining the correct size of Rings to be used in the Bushing being fitted: Pc. No. 524950 for Application Piston and Pc. No. 524949 for Equalizing Piston. As an alternate, we have a set of four Gages (packed in a neat metal box), identified by combination Pc. No. 88630 for Application Piston, and Pc. No. 87066 for Equalizing Piston, for the same purpose.

NOTE B—The Complete Self-Oiling Application and Equalizing Pistons specified for these Distributing Valves are interchangeable with the Complete Non-Self-Oiling Pistons previously furnished, except, when the Self-Oiling Equalizing Piston is used, Graduating Spring Seat (Pc. 540753, ref. 44) must be employed, or the former Graduating Stem (Pc. 69657) modified to its equivalent. However, the Graduating Stem (Pc. 69657) must be used with the Non-Self-Oiling Piston.

†NOTE C—Column headed "No. Per Pkg." indicates the items for which standard shipping packages have been established and the number contained in the package. Orders placed in these quantities and multiples thereof will facilitate shipments and provide convenient means for handling in storeroom stock.

†NOTE D—For appropriate Fittings, Cap Screws and Gaskets, see instructions on page 5.

Prices will be quoted upon application
Orders should give PIECE NUMBER and NAME of part wanted

No. 6-KR DISTRIBUTING VALVE

(Continued)

Piece No.	Ref. No.	‡No. Per Pkg.		Piece No.	Ref. No.	‡No. Per Pkg.	
531994	34		"A" Safety Valve (See Part Catalog 3216-6)	*511431		2	Application Piston Valve with Pilot Valve, Complete, with Ring (includes Pc. 511889 and 511648)
511752	35		Reservoir (with Lugs for Suspension) (includes two of 37 and four of 36)	*511889			Application Piston Valve (less Pilot Valve) Complete, with Ring (includes 68, 69b, 70 and 74)
514292	35		Reservoir (with Feet for Floor Installation) (includes two of 37 and four of 36)	511400	68		Application Piston Valve
20704	36		$\frac{5}{8}$ " x $2\frac{1}{4}$ " Distributing Valve Body Stud and Nut (4 Req'd)	81207	69a	50	$1\frac{5}{8}$ " Application Piston Valve Packing Ring (1st Repair)
10076	37		Drain Plug (2 Req'd)	40765	69b	50	$1\frac{5}{8}$ " Application Piston Valve Packing Ring (2nd Repair)
94649	39		Blanking Cover Gasket	45576	69c	50	$1\frac{5}{8}$ " Application Piston Valve Packing Ring (3rd Repair)
*58013	41	150	Reservoir Gasket	511407	70		Application Valve Seal
6753	42		$\frac{3}{8}$ " Ring Test Plug	511648			Pilot Valve and Stem, Complete (includes 71, 72 and 73)
1751	43	1000	Strainer	94009	71		Pilot Valve
540753	44	12	Graduating Spring Seat (See Note B)	517043	72		Pilot Valve Seal
69658	45		Cap Nut for Cylinder Cap	94008	73		Pilot Valve Stem
†69656	46		Graduating Spring	511401	74		Pilot Valve Seat
99499	51		Exhaust Slide Valve Spring Pin	†94006	75		Pilot Valve Spring
97378	62		Exhaust Slide Valve Spring Pin Lock	†39574	76		Application Piston Valve Spring
97379	64		Equalizing Slide Valve Spring Pin	518089	93		Piston Lubricating Wick (2 Req'd)
97378	65		Equalizing Slide Valve Spring Pin Lock	540751	94		Equalizing Piston Cap Nut
501154	66		Application Valve Bush	1635			$\frac{1}{4}$ " Pipe Plug (2 Req'd)
94648	67		Application Valve Bush Gasket				

*NOTE A—Unless otherwise specified, the 2nd Repair Ring is furnished with all combinations of Piston with Ring.

NOTE B—The Complete Self-Oiling Application and Equalizing Pistons specified for these Distributing Valves are interchangeable with the Complete Non-Self-Oiling Pistons previously furnished, except, when the Self-Oiling Equalizing Piston is used, Graduating Spring Seat (Pc. 540753, Ref. 44) must be employed, or the former Graduating Stem (Pc. 69657) modified to its equivalent. However, the Graduating Stem (Pc. 69657) must be used with the Non-Self-Oiling Piston.

‡NOTE C—Column headed "No. Per Pkg." indicates the items for which standard shipping packages have been established and the number contained in the package. Orders placed in these quantities and multiples thereof will facilitate shipments and provide convenient means for handling in storeroom stock.

†NOTE D—For Spring Identification Table, see page 5.

**NOTE E—The Reservoir Gasket (Ref. No. 41) is not a part of either portion, but of the Distributing Valve Complete.

Prices will be quoted upon application
Orders should give PIECE NUMBER and NAME of part wanted

No. 6-KR and No. 6-IKR DISTRIBUTING VALVES

FITTINGS

The WABCOTITE® or WABCOSEAL® Fittings used with these Distributing Valves are covered in Part Catalogs 3216-21 and 3216-22, respectively, which also indicate the Gaskets and Cap Screws to be used with the various Fittings. Any appropriate style of Fittings, for iron pipe or copper tube, may be applied to fit flanges as tabulated below:—

FLANGE SIZES FOR FITTINGS

Port Identification	Flange Size
B. Cylinder	3/4"
B. Pipe	3/4"
Main Res.	3/4"
Appl. Cyl. (2)	3/8"
Dist. V. Rel. (4)	3/8"
Dynamic Int. (6)	3/8"

SPRING IDENTIFICATION

The following table is shown to enable railroad men, storekeepers, and all Air Brake men to identify the various springs used in the Distributing Valves cataloged herein. It is based on calculated figures and the actual springs will vary somewhat, due to small differences in wire diameter, coil diameter, number of coils, etc. This tabulation is intended for identification only, and should not be used for any other purpose. It does not represent a specification for the springs mentioned.



SPRING IDENTIFICATION							
Pc. No.	Out. Dia. "A"	Dia. Wire "B"	Free Height "C"	* Approx. No. Turns	Material	Name of Spring	Where Used
69656	1 1/2"	7/32"	3 7/8"	11 1/2	Phos. Bz.	Graduating Spring	Nos. 6-KR, and 6-IKR Valves
94006	1 7/32"	.064"	2 1/8"	15 1/2	Phos. Bz.	Pilot Valve Spring	Nos. 6KR, and 6-IKR Valves
39574	1 3/16"	.080"	2 7/8"	7 1/2	Steel	Application Piston Valve Spring.	Nos. 6-KR, and 6-IKR Valves
53003	1 3/32"	.051"	1 1/8"	10	Phos. Bz.	Magnet Val. Spring	No. 6-IKR Dist. Valve

*Number of turns for each spring counted between the extreme ends of the wire.

Prices will be quoted upon application
Orders should give PIECE NUMBER and NAME of part wanted

No. 6-IKR DISTRIBUTING VALVES

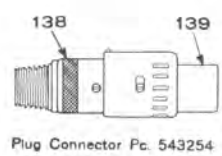
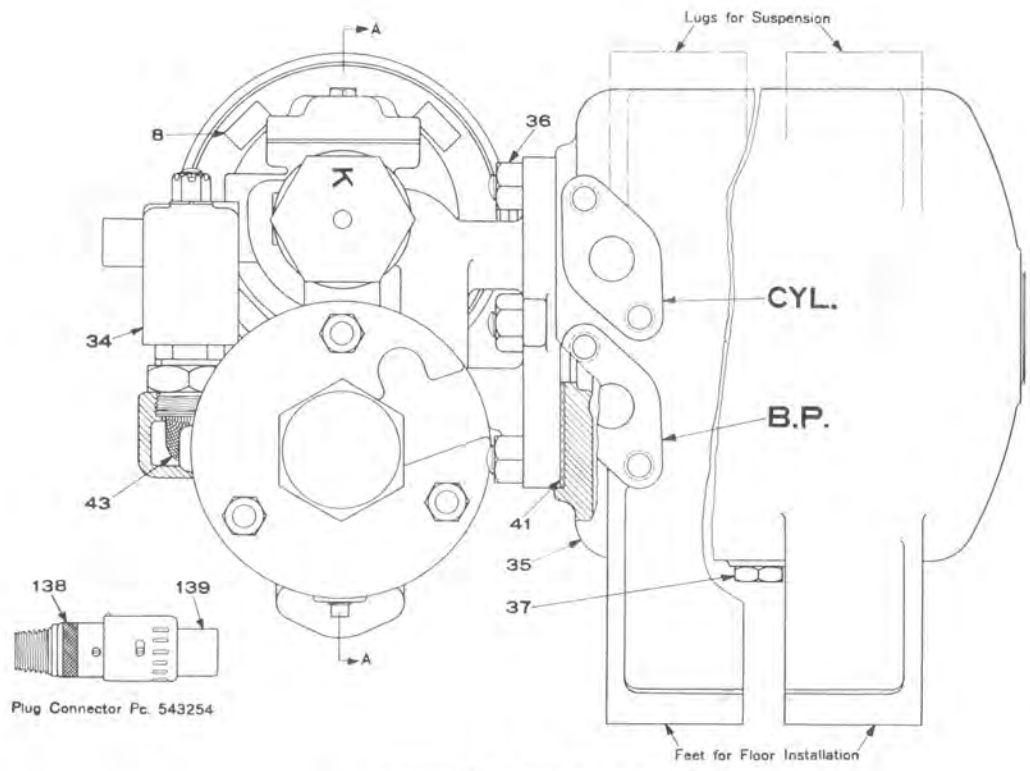
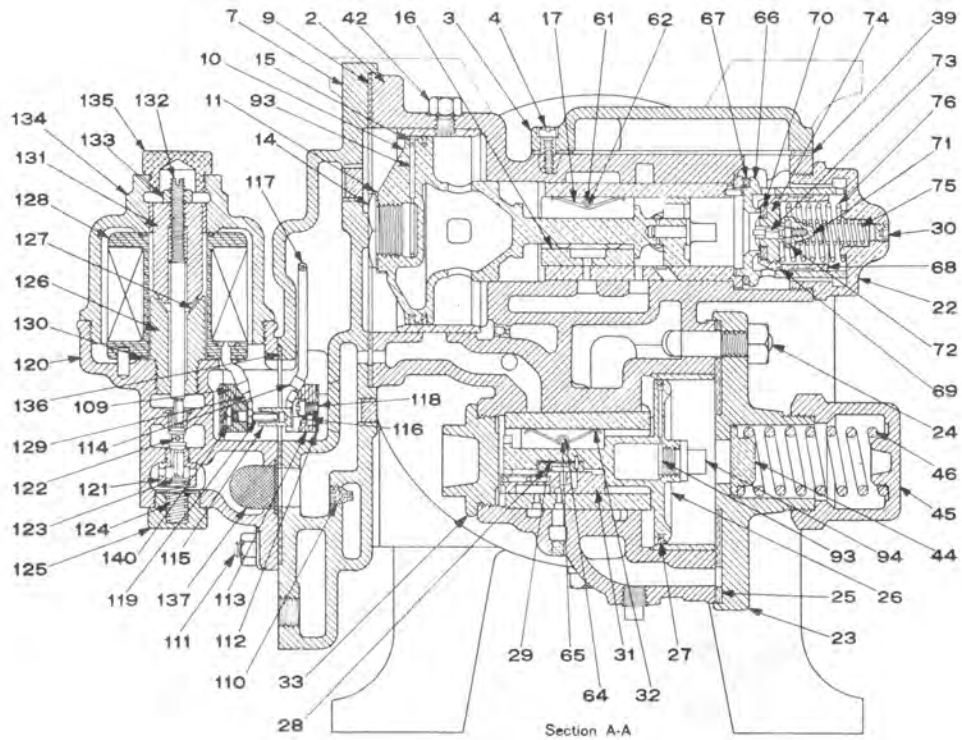

Approx. Net Weight 185 Lbs.

No. 6-IKR DISTRIBUTING VALVE

Distributing Valve Complete, With Safety Valve Less Fittings*	Valve Portion		Reservoir	
	Complete	Less Safety Valve	Complete Pc. No.	Mounting
542844	542923	542527	511752	Suspension Floor
542845	542923	542527	514752	

Piece No.	Ref. No.	‡ No. Per Pkg.	Description	Piece No.	Ref. No.	‡ No. Per Pkg.	Description
542521	2		Distributing Valve Body (includes 42 and two of pc. 1635)	540749	26	1	Equalizing Piston, Complete, less Ring (includes 93 and 94)
96247	3		Blanking Cover	85811	27a	50	3 1/2" Equalizing Piston Ring (1st Repair)
518711	4		.242" x 1 1/16" Blanking Cover Cap Screw (10 Req'd)	85812	27b	50	3 1/2" Equalizing Piston Ring (2nd Repair)
542524			Application Cylinder Cover, Complete (includes 7, 112, Pc. 543475, Pc. 543254 and two of 118)	85813	27c	50	3 1/2" Equalizing Piston Ring (3rd Repair)
543527	7		Application Cylinder Cover (includes 110 and four of 111)	85814	27d	50	3 1/2" Equalizing Piston Ring (4th Repair)
10836	8	50	1/2" x 1 7/8" Application Cylinder Cover Bolt and Nut (4 Req'd)	94964	28		Equalizing Graduating Valve
70630	9		Application Cylinder Cover Gasket	12887	29		Equalizing Graduating Valve Spring
*543259			Application Piston, Complete, with Rings (includes 10 and two of 15b)	515794	30		1/8" Pipe Plug
540745	10	1	Application Piston, Complete, less Rings (includes 11, 14 and 93)	80825	31	12	Equalizing Slide Valve
506611	11		Lock Washer	12573	32	200	Equalizing Slide Valve Spring
540744	14		Piston Cap Nut	18602	33		Lower Cap Nut
87017	15a	50	4" Application Piston Ring (1st Repair) (2 Req'd)	531994	34		"A" Safety Valve (see Part Catalog 3216-6)
87018	15b	50	4" Application Piston Ring (2nd Repair) (2 Req'd)	511752	35		Reservoir (with Lugs for Suspension) (includes two of 37 and four of 36)
87019	15c	50	4" Application Piston Ring (3rd Repair) (2 Req'd)	514292	35		Reservoir (with Feet for Floor Installation) (includes two of 37 and four of 36)
87020	15d	50	4" Application Piston Ring (4th Repair) (2 Req'd)	20704	36		5/8" x 2 1/4" Distributing Valve Body Stud and Nut (4 Req'd)
96249	16	4	Exhaust Slide Valve	10076	37		Drain Plug (2 Req'd)
93946	17		Exhaust Slide Valve Spring	94649	39		Blanking Cover Gasket
501460	22		Application Valve Nut (includes 30)	** 58013	41	150	Reservoir Gasket
540796			Cylinder Cap, Complete (includes 23, 44, 45 and 46)	6753	42		3/8" Test Plug
69659	23		Cylinder Cap	1751	43	1000	Strainer
10836	24	50	1/2" x 1 7/8" Cylinder Cap Bolt and Nut (3 Req'd)	540753	44	12	Graduating Spring Seat
80043	25		Cylinder Cap Gasket	69658	45		Cap Nut for Cylinder Cap
*543201			Equalizing Piston, Complete, with Ring (includes 26 and 27b)	†69656	46		Graduating Spring
				99499	61		Exhaust Slide Valve Spring Pin
				97378	62		Exhaust Slide Valve Spring Pin Lock
				97379	64		Equalizing Slide Valve Spring Pin
				97378	65		Equalizing Slide Valve Spring Pin Lock
				501154	66		Application Valve Bush
				94648	67		Application Valve Bush Gasket

*NOTE A—Unless otherwise specified, the 2nd Repair Ring is furnished with all combinations of Piston with Ring. We are prepared to furnish Cylindrical Gages for use in determining the correct size of Rings to be used in the Bushing being fitted: Pc. No. 524950 for Application Piston and Pc. No. 524949 for Equalizing Piston. As an alternate, we have a set of four Gages (packed in a neat metal box), identified by combination Pc. No. 88630 for Application Piston, and Pc. No. 87066 for Equalizing Piston, for the same purpose.

‡NOTE B—Column headed "No. Per Pkg." indicates the items for which standard shipping packages have been established and the number contained in the package. Orders placed in these quantities and multiples thereof will facilitate shipments and provide convenient means for handling in storeroom stock.

†NOTE C—For Spring Identification Table, see page 5.

*NOTE D—For appropriate Fittings, Cap Screws and Gaskets, see instructions on page 5.

**NOTE E—The Reservoir Gasket (Ref. No. 41) is not a part of either portion, but of the Distributing Valve Complete.

Prices will be quoted upon application
Orders should give PIECE NUMBER and NAME of part wanted

No. 6-IKR DISTRIBUTING VALVE

(Continued)

Piece No.	Ref. No.	† No. Per Pkg.	Description	Piece No.	Ref. No.	† No. Per Pkg.	Description
*511431			Application Piston Valve with Pilot Valve, Complete, with Ring (includes Pc. 511889 and 511648)	3380	118		#10 x 5/8" Terminal Block Screw (4 Req'd)
*511889			Application Piston Valve (less Pilot Valve) Complete, with Ring (includes 68, 69b, 70 and 74)	527702			Dynamic Interlock Magnet Portion, Complete, (FA-4)
511400	68		Application Piston Valve	529341			Magnet Body, Assembly (includes 112, 120, 123, 124, 125, Pc. 534086, two of 118, 122 and 129)
81207	69a	50	1 5/8" Application Piston Valve Packing Ring (1st Repair)	534086			Terminal Block, Complete (Plug) (includes 109, two of 119 and 140)
40765	69b	50	1 5/8" Application Piston Valve Packing Ring (2nd Repair)	533933	119		Plug Contact (2 Req'd)
45576	69c	50	1 5/8" Application Piston Valve Packing Ring (3rd Repair)	527374	120		Magnet Body (Includes 121)
511407	70		Application Valve Seal	527373	121		Lower Valve Seat
511648			Pilot Valve and Stem, Complete (includes 71, 72 and 73)	521280	122		Magnet Valve (2 Req'd)
94009	71		Pilot Valve	527389	123		Spring Seat
517043	72		Pilot Valve Seal	†53003	124		Magnet Valve Spring
94008	73		Pilot Valve Stem	528078	125		Magnet Valve Cap Nut
511401	74		Pilot Valve Seat	521282	126		Magnet Core
†94006	75		Pilot Valve Spring	503943	127		Magnet Core Washer
†39574	76		Application Piston Valve Spring	525217	128		Magnet Coil
518089	93		Piston Lubricating Wick (2 Req'd)	533086	129		Terminal Clip (Magnet Portion) (2 Req'd)
540751	94		Equalizing Piston Cap Nut	520902	130		Magnet Spool Gasket (2 Req'd)
533962	109		Terminal Block (Magnet Portion)	521284	131		Armature
96190	110		1/8" Choke Plug (3/64" Drill)	521285	132		Armature Stem
84909	111		3/8" x 1 1/2" Magnet Body Stud and Nut (4 Req'd)	96500	133		Armature Stem Nut
514992	112		Terminal Block Insulation Plate (2 Req'd)	521287	134		Magnet Coil Housing
543475			Terminal Block, Complete (Socket) (includes 113, two of 114, 115, 116 and 117) (Application Cylinder Cover)	502453	135		Magnet Cap Nut
533962	113		Terminal Block (Application Cylinder Cover)	**527375	136		Magnet Body Gasket
533086	114		Terminal Clip (Application Cylinder Cover) (2 Req'd)	**521663	137		Port Filter (3 Req'd)
534042	115		Socket Terminal (2 Req'd)	543254			Plug Connector, Complete (includes 138 and 139)
5741	116		#10 Terminal Nut (2 Req'd)	543252	138		Receptacle, Complete (includes Receptacle Housing, Pc. 542643 and Male Contact Unit, Pc. 542710)
543488	117		Lead (#18 wire, 7" long) (2 Req'd)	543253	139		Plug, Complete (includes Plug Shell, Pc. 542642 and Female Contact Unit, Pc. 542711)
				5741	140		#10 Contact Nut (2 Req'd)
				1635			1/4" Pipe Plug (2 Req'd)

*NOTE A—Unless otherwise specified, the 2nd Repair Ring is furnished with all combinations of Piston with Ring.

†NOTE B—Column headed "No. Per Pkg." indicates the items for which standard shipping packages have been established and the number contained in the package. Orders placed in these quantities and multiples thereof will facilitate shipments and provide convenient means for handling in storeroom stock.

†NOTE C—For Spring Identification Table, see page 5.

**NOTE D—The Magnet Body Gasket (Ref. No. 136) and the Port Filter (Ref. No. 137) are not a part of either portion, but of the Distributing Valve Complete.

OFFICES

ATLANTA 3 Candler Building
 BOSTON 16 Statler Building
 CHICAGO 4 Railway Exchange Building
 CLEVELAND 15 Midland Building
 DENVER 2 Denver National Building
 HOUSTON 2, TEX. Commerce Building
 LOS ANGELES 14 Pacific Electric Building

MEXICO, D. F., MEXICO Edificio Aztlan
 NEW YORK 1 Empire State Building
 ST. LOUIS 3 Shell Building
 ST. PAUL 1 First National Bank Building
 SAN FRANCISCO 5 Matson Building
 SEATTLE 1 Securities Building
 WASHINGTON 6, D. C. Ring Building

Prices will be quoted upon application
 Orders should give PIECE NUMBER and NAME of part wanted

DIRT COLLECTORS

Parts Catalog No. 3216-2

August, 1956

(Supersedes Issue of June, 1948, and Parts Catalogs 3216-2A, 3216-2B and 3216-2C)

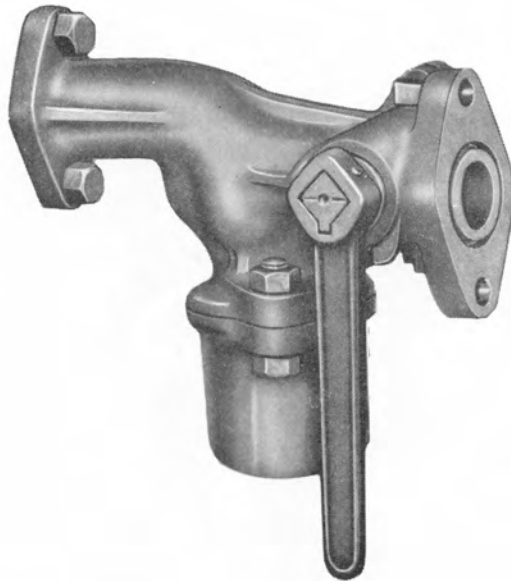

Westinghouse Air Brake
COMPANY

AIR BRAKE DIVISION  WILMERDING, PA.

COMBINED DIRT COLLECTOR AND CUT-OUT COCK
WITH "O" RING SEALED KEY

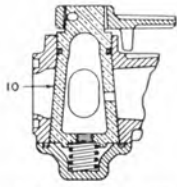

Partial View of Cock Key With Side Vent Used With Comp. Pc. 553924

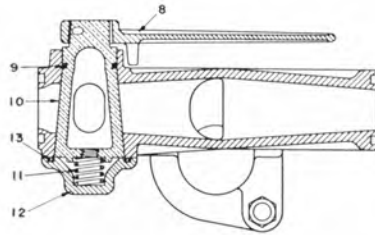

Section A-A-A-A

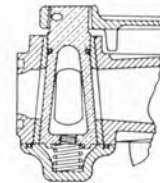

Partial View of Cock Bush Used with Complete Pc. 554209

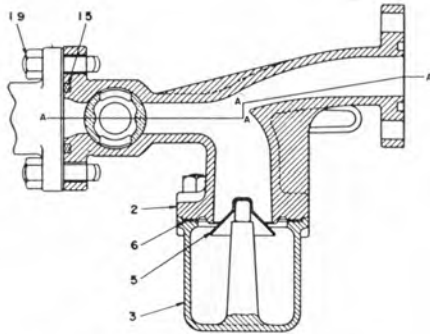

Section B-B-B-B

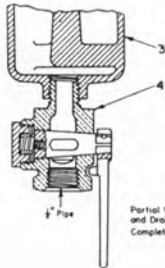

Partial View of Dirt Chamber and Drain Cock used with Complete Pc. 553797

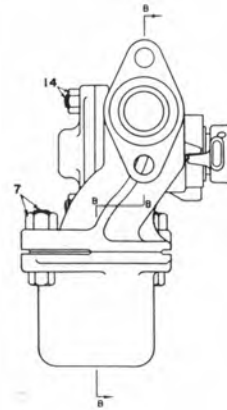

Approx. Net Weights

Pc. 552000	14½ lbs.
Pc. 553797	16 lbs.
Pc. 553924	14½ lbs.
Pc. 554209	15½ lbs.

COMBINED DIRT COLLECTOR AND CUT-OUT COCK
WITH "O" RING SEALED KEY

1 in. Combined Dirt Collector and Cut-Out Cock with "O" Ring Sealed Key (Includes Ref. Nos. 2 to 14b).....	552000			
1 in. Combined Dirt Collector and Cut-Out Cock with "O" Ring Sealed Key and 1/2 in. Drain Cock (Includes Ref. Nos. 2 to 14b) . .		553797		
1 in. Combined Dirt Collector and Cut-Out with "O" Ring Sealed Key and 1/4 in. Vent (Includes Ref. Nos. 2 to 14b).....			553924	
1 in. Combined Dirt Collector and Cut-Out Cock with Bush and "O" Ring Sealed Key (Includes Ref. Nos. 2 to 14b).....				554209

Ref. No.	Description	Piece Number			
2	Dirt Collector Body	552014	552014	553923	554210
3	Dirt Chamber with Stem.....	78421	78422	78421	78421
4	1/2 in. Drain Cock (See P.C. 3216-4, Sup. 7)		514563		
5	Check Valve			75551	
6	Dirt Chamber Gasket.....			75932	
7a	Dirt Chamber Bolt (2 Req'd).....			538995	
7b	Dirt Chamber Nut (2 Req'd).....			2505	
8	Cock Key Handle.....			94867	
9	Cock Key Sealing Ring	524794	524794	524794	536578
*10	Cock Key	552015	552015	553921	554213
*11	Cock Key Spring.....			2098	
12	Cock Key Cover			94942	
13	Cock Key Cover Gasket.....			94826	
14a	Cock Key Cover Bolt (2 Req'd).....			82007	
14b	Cock Key Cover Nut (2 Req'd).....			1296	
†15	Fitting Gasket.....			93986	
†19a	1/2 x 1 3/4 in. Fitting Bolt (2 Req'd Per Fitting).....			11001	
†19b	1/2 in. Fitting Nut (2 Req'd Per Fitting).....			2505	

*NOTE—For Spring Identification Table or for Repair Size Keys Table, Refer to Page 9.

†NOTE—Not included in the Complete Piece Number. Must be ordered separately.

For WABCOSEAL® Fittings, Refer to Parts Catalog No. 3216-22, which also indicates the Gasket to be used with the various Fittings.

Flange Faces on Body of Dirt Collector and 1 in. Fittings are grooved to use Fitting Gasket, Pc. 93986. When a Flange Fitting is attached to the Dirt Collector, two Gaskets are required per Fitting.

When the Dirt Collector is attached to the Pipe Bracket one Gasket and two 1/2 x 1 1/2 in. Hex Head Bolts, Pc. 5951, are required.

NOTE A—Bodies of obsolete devices no longer will be furnished for repair parts. If orders are received for obsolete bodies, we will furnish a new body and standard key complete with "O" ring. The handles for obsolete Pc. Nos. 543493 and 517329 will not fit the new standard key, therefore, the handle, Pc. 94867, will be furnished with the new body and key when obsolete bodies are ordered for repair parts. All other parts will be furnished for repair purposes.

Prices will be quoted upon application

Orders should give PIECE NUMBER and NAME of part wanted

COMBINED DIRT COLLECTOR AND CUT-OUT COCK WITH
QUICK CLEANING FEATURE AND "O" RING SEALED KEY

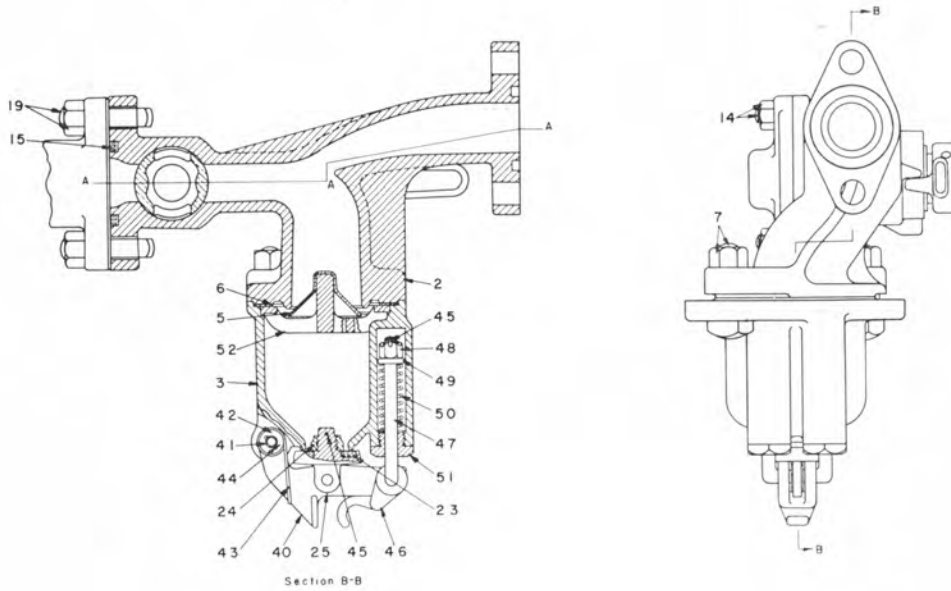
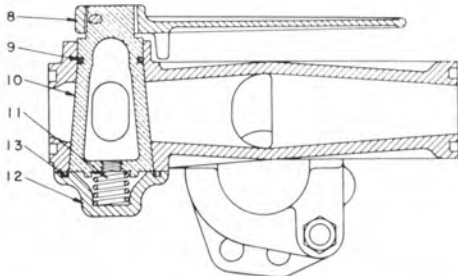

14³/₄ Lbs.
Approx. Net Weight

COMBINED DIRT COLLECTOR AND CUT-OUT COCK
WITH QUICK CLEANING FEATURE AND "O" RING SEALED KEY

1 in. Combined Dirt Collector and Cut-Out Cock with Quick Cleaning
Feature and "O" Ring Sealed Key.....554634

Ref. No.	Description	Piece Number
2	Dirt Collector Body.....	552014
	Removable Dirt Chamber with Quick Cleaning Feature, Complete (Includes Ref. Nos. 3 & 23 to 52).....	95385
3	Dirt Chamber Body.....	95386
5	Check Valve.....	75551
6	Dirt Chamber Gasket.....	75932
7a	Dirt Chamber Bolt (2 Req'd).....	11001
7b	Dirt Chamber Nut (2 Req'd).....	2505
8	Cock Key Handle.....	94867
9	Cock Key Sealing Ring.....	524794
*10	Cock Key.....	552015
*11	Cock Key Spring.....	2098
12	Cock Key Cover.....	94942
13	Cock Key Cover Gasket.....	94826
14a	Cock Key Cover Bolt (2 Req'd).....	82007
14b	Cock Key Cover Nut.....	1296
†15	Fitting Gasket.....	93986
†19a	1/2 x 1 3/4 in. Fitting Bolt (2 Req'd Per Fitting).....	11001
†19b	1/2 in. Fitting Nut (2 Req'd Per Fitting).....	2505
23	Valve Seal.....	72433
24	Valve Nut.....	1794
25	Valve.....	93482
40	Cross Lever.....	95391
41	Lever Fulcrum.....	93483
42	Sleeve (2 Req'd).....	95393
43	Cross Lever Spring.....	93487
44	3/32 in. Cotter (2 Req'd).....	4045
45	1/16 in. Cotter (3 Req'd) (1 for Valve, 2 for Spring Guide).....	5735
46	Cam Yoke.....	95390
47	Spring Guide (2 Req'd).....	95387
48	Spring Guide Castle Nut (2 Req'd).....	95389
49	Spring Guide Washer (2 Req'd).....	95392
50	Guide Spring (2 Req'd).....	55280
51	Spring Cylinder Nut (2 Req'd).....	95388
52	Check Valve Guide.....	93481

*NOTE—For Spring Identification Table or for Repair Size Keys Table, See Page 9.

†NOTE—Not included in the Complete Piece Number. Must be ordered separately.

For WABCOSEAL® Fittings, Refer to Parts Catalog No. 3216-22, which also indicates the Gasket to be used with the various Fittings.

Flange Faces on Body of Dirt Collector and 1 in. Fittings are grooved to use Fitting Gasket, Pc. 93986. When a Flange Fitting is attached to the Dirt Collector, two Gaskets are required per Fitting.

When the Dirt Collector is attached to the Pipe Bracket one Gasket and two 1/2 x 1 1/2 in. Hex Head Bolts, Pc. 5951, are required.

NOTE A—The handles for obsolete Pc. Nos. will not fit the new standard key, therefore, the handle Pc. 94867, will be furnished with the new body and key when obsolete bodies are ordered for repair parts.

Prices will be quoted upon application

Orders should give PIECE NUMBER and NAME of part wanted

CENTRIFUGAL DIRT COLLECTOR
ARRANGED FOR WABCOSEAL® FITTINGS

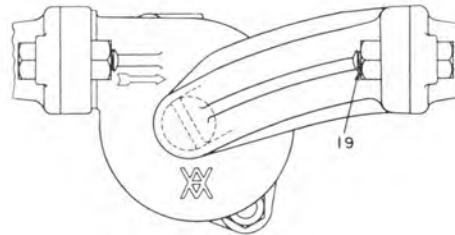
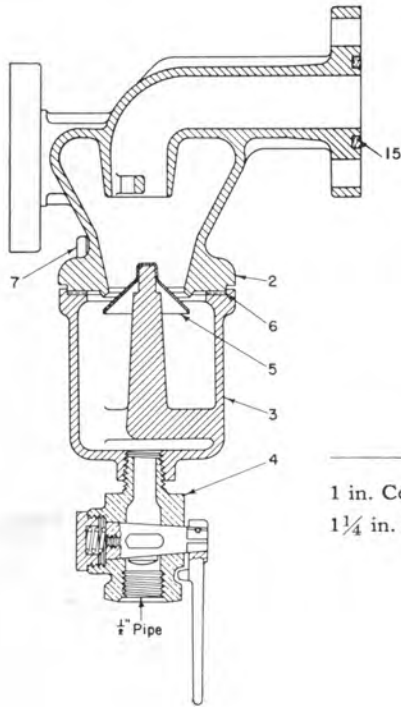

	Pc. No.	Approx. Net Weight
1 in. Centrifugal Dirt Collector with 1/2 in. Drain Cock...	507072	13 lbs.
1 1/4 in. Centrifugal Dirt Collector with 1/2 in. Drain Cock.	508844	14 1/2 lbs.

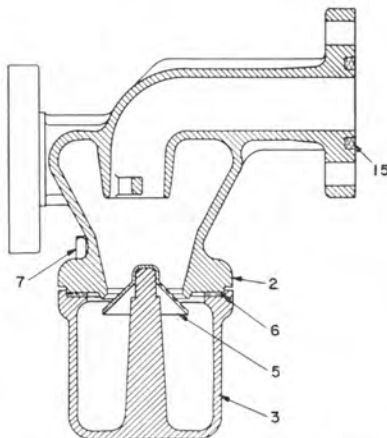
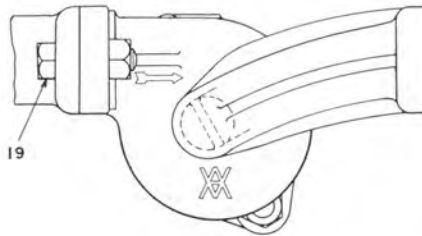

1 in. Centrifugal Dirt Collector Pc. No. 515195
Approx. Net Weight 10 1/2 lbs.

**CENTRIFUGAL DIRT COLLECTOR
ARRANGED FOR WABCOSEAL® FITTINGS**

1 in. Centrifugal Dirt Collector with 1/2 in. Drain Cock (Includes Ref. Nos. 2 to 7b)	507072	
1 1/4 in. Centrifugal Dirt Collector with 1/2 in. Drain Cock (Includes Ref. Nos. 2 to 7b)		508844

Ref. No.	Description	Piece Number	
2	Dirt Collector Body	507187	508781
3	Dirt Chamber with Stem		78422
4	1/2 in. Drain Cock (See P. C. 3216-4, Sup. 7)		99080
5	Check Valve		75551
6	Dirt Chamber Gasket		75932
7a	Dirt Chamber Bolt (2 Req'd)		11001
7b	Dirt Chamber Nut (2 Req'd)		2505
†15	Fitting Gasket	93986	94970
†19a	1/2 x 1 3/4 in. Fitting Bolt (2 Req'd Per Fitting)	3205	
†19a	5/8 x 1 7/8 in. Fitting Bolt (2 Req'd Per Fitting)		546766
†19b	1/2 in. Nut (2 Req'd Per Fitting)	2505	
†19b	5/8 in. Nut (2 Req'd Per Fitting)		27009

1 in. Centrifugal Dirt Collector (Includes Ref. Nos. 2 to 7b) 515195

Ref. No.	Description	Piece Number	
2	Dirt Collector Body	507187	
3	Dirt Chamber with Stem		78421
5	Check Valve		75551
6	Dirt Chamber Gasket		75932
7a	Dirt Chamber Bolt (2 Req'd)		11001
7b	Dirt Chamber Nut (2 Req'd)		2505
†15	Fitting Gasket	93986	
†19a	Fitting Bolt (2 Req'd Per Fitting)		3205
†19b	Fitting Nut (2 Req'd Per Fitting)		2505

*NOTE—For Spring Identification Table or for Repair Size Keys Table, Refer to Page 9.

†NOTE—Not included in the Complete Piece Number. Must be ordered separately.

For WABCOSEAL® Fittings, Refer to Parts Catalog No. 3216-22 which also indicates the Gasket to be used with the various Fittings.

Flange Faces on Body of Dirt Collectors and Fittings are grooved to use Fitting Gasket, Pc. 94970, (for 1 1/4 in. Sizes) or, Pc. 93986 (for 1 in. Sizes). When a Flange Fitting is attached to the Dirt Collector, two Gaskets are required per fitting. When the Dirt Collector is attached to the Pipe Bracket, one Gasket and two 1/2 x 1 1/2 in. Hex Head Bolts, Pc. 5951, are required.

Prices will be quoted upon application
Orders should give PIECE NUMBER and NAME of part wanted

CENTRIFUGAL DIRT COLLECTORS WITH TAPPED BODIES

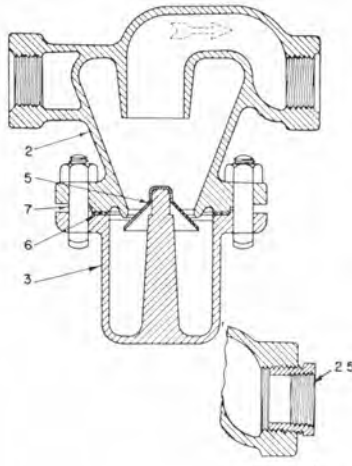

Section A-A
Showing Reducing Bushing
Pc. 2178 used with Pc. 77883

Ref. No.	Description	Size (inches)			
		3/4	1	1 1/4	1 1/4
2	Centrifugal Dirt Collector, Complete.....	77573	75751	75753	77883
	Body.....	77578	75935	75936	75932
	3	Dirt Chamber with Stem.....	78421	78421	78421
5	Check Valve.....	75551	75551	75551	75551
6	Gasket.....	75932	75932	75932	75932
7a	Bolt (2 Req'd).....	11001	11001	11001	11001
7b	Nut (2 Req'd).....	2505	2505	2505	2505
25	Reducing Bush (1 1/4 x 1 in.).....	2178
Approx. Net Weight (Lbs.)		10	12	14	14

CENTRIFUGAL DIRT COLLECTORS WITH TAPPED BODIES
AND 1/2 IN. DRAIN COCK

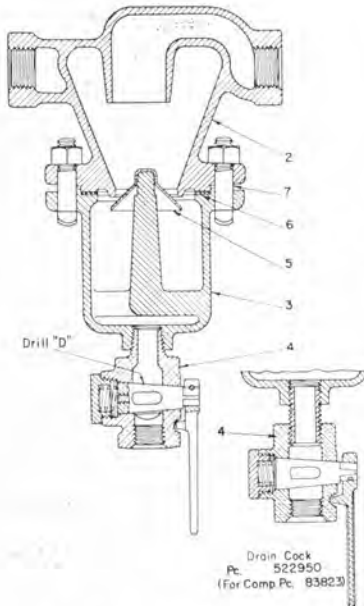

Drain Cock
Pc. 522950
(For Comp Pc. 83823)

Ref. No.	Description	Size (inches)				
		3/4	1	1 1/4		
2	Centrifugal Dirt Collector, Complete, with Drain Cock.....	501136	514334	501138	83823	501134
	Body.....	77578		75935		75936
3	Dirt Chamber.....	78422		78422		99080
*4	1/2 in. Drain Cock.....	99080 512011		99080 522950		99080
5	Check Valve.....	75551		75551		
6	Dirt Chamber Gasket.....	75932		75932		
7a	1/2 x 1 1/4 in. Dirt Chamber Bolt (2 Req'd).....	11001		11001		
7b	1/2 in. Dirt Chamber Nut (2 Req'd).....	2505		2505		
Approx. Net Weight (Lbs.)		12		14		16

*NOTE A—For Details of 1/2 in. Drain Cocks, see Parts Catalog 3216-4, Sup 7. Drain Cock Pc. No. 512011 has 1/4 in. Vented Key, Drain Cock Pc. No. 522950 has 1/2 in. Tapped Body and includes 1/2 x 1 1/2 in. Threaded Nipple, Pc. 81465.

Prices will be quoted upon application

Orders should give PIECE NUMBER and NAME of part wanted

MISCELLANEOUS

SPRING IDENTIFICATION

The following table is shown to enable railroad men, storekeepers and all Air Brake men to identify the spring used in the Cut-Out Cock cataloged herein. The actual spring will vary somewhat, due to small differences in wire diameter, coil diameter, number of turns, etc. This tabulation is intended for identification only and should not be used for any other purpose. It does not represent a specification for the spring mentioned.

		SPRING IDENTIFICATION					
Pc. No.	Approx. Out. Dia. "A"	Approx. Dia. Wire "B"	Approx. Free Ht. "C"	*Approx. No. Turns	Material	Name of Spring	Where Used
2098	$5\frac{3}{4}$ in.	.105 in.	$1\frac{7}{8}$ in.	5	Stainless Steel	Key Spring	Cut-Out Cock

*NOTE—Number of turns of each spring counted between extreme ends of wire.

COMBINED DIRT COLLECTORS AND CUT-OUT COCK
REPAIR SIZE KEYS

Repair Size	Description	Pc. No.
1 st 2 nd	Repair Size Keys for Unbushed Type 1 in. Combined Dirt Collector and Cut-Out Cock	530907 530908
1 st 2 nd	Repair Size Keys for Bushed Type 1 in. Combined Dirt Collector and Cut-Out Cock	530909 530910
Standard 1 st 2 nd	Standard and Repair Size Keys Complete with "O" Ring for Unbushed Type 1 in. Combined Dirt Collector and Cut-Out Cock with "O" Ring Sealed Key	552235 552236 552237
Standard 1 st 2 nd	Standard and Repair Size Keys Complete with "O" Ring for 1 in. Combined Dirt Collector and Cut-Out Cock with $\frac{1}{4}$ in. Vent and "O" Ring Sealed Key	554635 555793 555794
Standard 1 st 2 nd	Standard and Repair Size Keys Complete for 1 in. Combined Dirt Collector and Cut-Out Cock with Bush and "O" Ring Sealed Key	554632 555789 555790

Cock Key Cover for "ABLC" Conversion Equipment
Utilizing "AB" Valve without No. 11 Pipe Connection 540530
Mounting Bracket (Not Shown) 506501

Prices will be quoted upon application
Orders should give PIECE NUMBER and NAME of part wanted

CONVERSION KITS TO MODIFY 1 in. COMBINED DIRT COLLECTOR
AND CUT-OUT COCK TO USE "O" RING SEALED KEY

HAND REAMING KIT

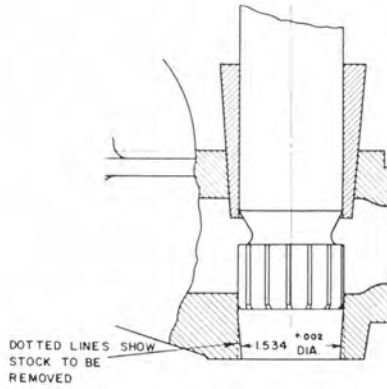

Description	Pc. No.
Reamer and Guide, Complete.....	553591
Reamer.....	553590
Guide Bush.....	553589

MACHINE REAMING KIT

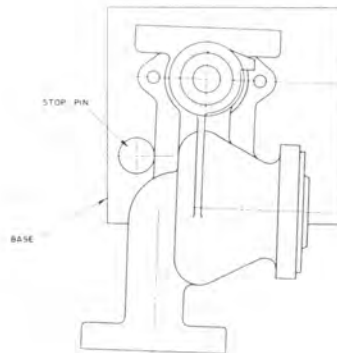
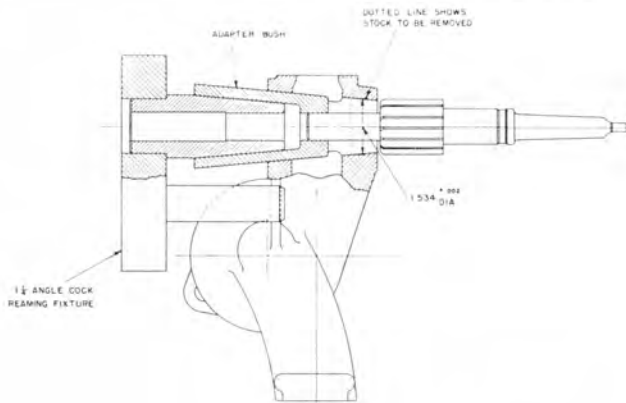

Description	Pc. No.
Reamer Kit, Complete.....	552228
Reamer, Complete.....	552229
Reamer Holder.....	550738
Reamer (1.534 in. dia.).....	552230
Reamer Pilot.....	550740
Adapter Bush.....	552231
Reamer Fixture, Complete.....	550996

NOTE A—If Tool Kit Pc. 550994, for modifying 1 1/4 in. Angle Cock is available, change Reamer Pc. 550739 (1.204 in. Dia.) to Reamer Pc. 552230 (1.534 in. Dia.) and use adapter Pc. 552231. Bodies of the Obsolete Bushed Cock Type can not be modified by the above Reaming Kits.

Prices will be quoted upon application
Orders should give PIECE NUMBER and NAME of part wanted

INDEX

	Pc.	Page
1 in. Combined Dirt Collector and Cut-Out Cock	552000	3
with 1/2 in. Drain Cock	553797	3
with 1/4 in. Vent	553924	3
with Bushed Cock	554209	3
with Quick Cleaning Feature	554634	5
 Centrifugal Dirt Collector Arranged for WABCOSEAL® Fittings		
1 in. Dirt Collector	515195	7
1 in. Dirt Collector with 1/2 in. Drain Cock	507072	7
1 1/4 in. Dirt Collector with 1/2 in. Drain Cock	508844	7
 Centrifugal Dirt Collector with Tapped Body		
3/4 in. Dirt Collector	77573	8
3/4 in. Dirt Collector with 1/2 in. Drain Cock	501136	8
3/4 in. Dirt Collector with 1/2 in. Drain Cock (Key Vented)	514334	8
1 in. Dirt Collector	75751	8
1 in. Dirt Collector with 1/2 in. Drain Cock	501138	8
1 in. Dirt Collector with 1/2 in. Drain Cock with Tapped Body and Nipple	83823	8
1 1/4 in. Dirt Collector	75753	8
1 1/4 in. Dirt Collector with Reducing Bushing	77883	8
1 1/4 in. Dirt Collector with 1/2 in. Drain Cock	501134	8
 Spring Identification		9
 Miscellaneous Information		9
 Repair Size Keys		9
 Conversion Kits for "O" Ring Application		10

Westinghouse Air Brake Company

Air Brake Division
WILMERDING, PA., U.S.A.

OFFICES

ATLANTA 3	Candler Building
CHICAGO 4	Railway Exchange Building
CLEVELAND 15	Midland Building
DENVER 2	Gas and Electric Building
HOUSTON 2, TEX.	Commerce Building
MEXICO, D. F., MEXICO	Edificio Aztlan
NEW YORK 1	Empire State Building
ST. LOUIS 3	Shell Building
ST. PAUL 1	First National Bank Building
SAN FRANCISCO 5	Matson Building
SAO PAULO, BRASIL	Largo Paisandu, 72
WASHINGTON 6, D. C.	Ring Building

Westinghouse Air Brake Company

Wilmerding, Pa., U. S. A.



(OB Type)

Air Strainers

Part Catalog No. 3216-2

Supplement No. 11

October, 1947

(SUPERSEDING STRAINER SECTION OF FEB. 1940 ISSUES OF 3216-2 SUP. 11 AND T-3516-2)

"OB" AIR STRAINERS

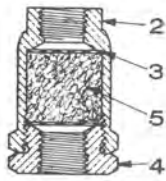

Type OB-1
Approx. Net Wt.
3/4 Lbs.

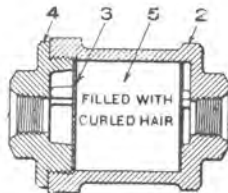

Type OB-2
Approx. Net Wt. 1 5/8 Lbs.

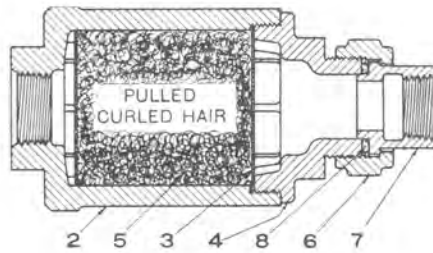

Type OB-4
Approx. Net Wt. 1 7/8 Lbs.

COMPLETE PIECE NUMBERS

Type	OB-1			OB-2						OB-4		
	Size	1/4"	1/4"x3/8"	3/8"	1/4"	3/8"	3/8"x1/4"	3/8"x1/2"	1/2"	1/2" Brass	3/4"	1"
		95309	*528759	79452	57349	3272	42636	50700	6997	525250	70800	69660

Ref. No.	Detail Piece Numbers	Detail Piece Numbers											
		2	3	4	5	6	7	8	9	10	11	12	
2	Body	95307	95307	79453	57317	3273	3273	3273	6994	525243	70757	69807	
3	Strainer Plate (2 Req'd)	79454	79454	79454	1044	1044	1044	1044	1044	525249	69808	69808	
4	Cap Nut	99691	*528758	79455	42637	3274	42637	50692	6995	525245	70758	69809	
5	Curled Hair	2 gr.	2 gr.	2 gr.	1/2 oz.	1/2 oz.	1/2 oz.	1/2 oz.	1/2 oz.	1/2 oz.	1 5/8 oz.	1 5/8 oz.	
6	Union Nut	3306	1749	
7	Union Swivel	3307	1750	
8	Union Gasket	87814	87726	

*NOTE—1/4"x3/8" OB-1 Strainer, Pc. 528759, has Cap Nut provided with stud fitting threaded for 3/8" pipe.

"OB" AIR STRAINERS WITH CHOKE FITTING

Pc. No. 502845 3/8" OB-1 Strainer with Choke Fitting (1/32" Drill), Complete

Pc. No. 516141 3/8" OB-1 Strainer with Choke Fitting (.0785", No. 47 Drill), Complete

Pc. No.	Ref. No.	Description
79452		3/8" OB-1 Strainer, Complete, less Choke Fitting
79453	2	Body
79454	3	Strainer Plate (2 Req'd)
79455	4	Cap Nut
	5	Curled Hair (2 gr.)
503823	6	Choke Fitting
95998	7	Choke Plug (1/32" Drill) (for Pc. No. 502845)
516142	7	Choke Plug (.0785" Drill) (for Pc. No. 516141)

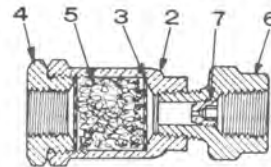

Approx. Net Wt.
1 1/8 Lbs.

NOTE—For STRAINER AND CHECK VALVE, Types C-1 and D-1, see Part Catalog 3216-24.

Prices will be quoted upon application

Orders should give PIECE NUMBER and NAME of part wanted

“OC” AND “OD” AIR FILTERS (STRAINERS)

3/8" OC-1 CARTRIDGE TYPE FILTER

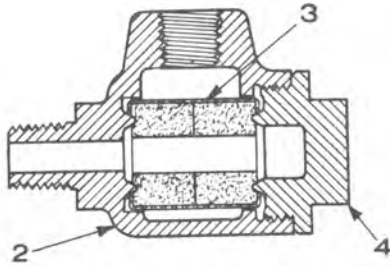

Approx. Net Wt. 1 1/8 Lbs.

Pc. No. 508053 3/8" OC-1 Air Filter, Complete

Pc. No.	Ref. No.	Description
508052	2	Filter Body
514975	3	Filter Cartridge
506635	4	Cap Nut

OD-1 FILTER AND STRAINER

COMPLETE PIECE NUMBERS					
Ref. No.	Size	1/4"			
		522170	*529847	†526898	521716
		Detail Piece Numbers			
2	Body	522169	529846	522169	521717
4	Filter (Strainer) Element	521398	521398	526835	521398
7	Seal	521631	521631	521631	521631
8	Cap Nut	521713	526697	526697	521713

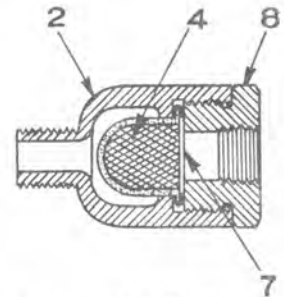

Approx. Net Wt. 1/2 Lbs.

*NOTE A—1/4" OD-1 Filter, Pc. 529847, is non-magnetic.

†NOTE B—1/4" OD-1 Strainer, Pc. 526898, includes a strainer element of wire-mesh only, without felt.

3/8"x1/4" OD-2 FILTER WITH CHOKE

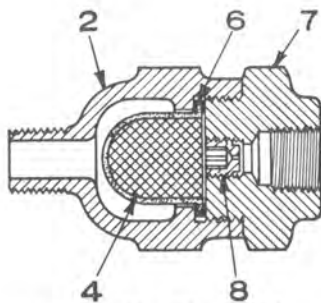

Approx. Net Wt. 1 1/4 Lbs.

Pc. No. 523702 3/8"x1/4" OD-2 Air Filter with Choke, Complete

Pc. No.	Ref. No.	Description
523711	2	Filter Body
521663	4	Filter Element
523188	6	Seal
523712	7	Cap Nut
523713	8	1/8" Choke Plug (.026", No. 71 Drill)

Prices will be quoted upon application

Orders should give PIECE NUMBER and NAME of part wanted

SIGNAL PIPE STRAINERS WITH WABCOTITE FITTINGS

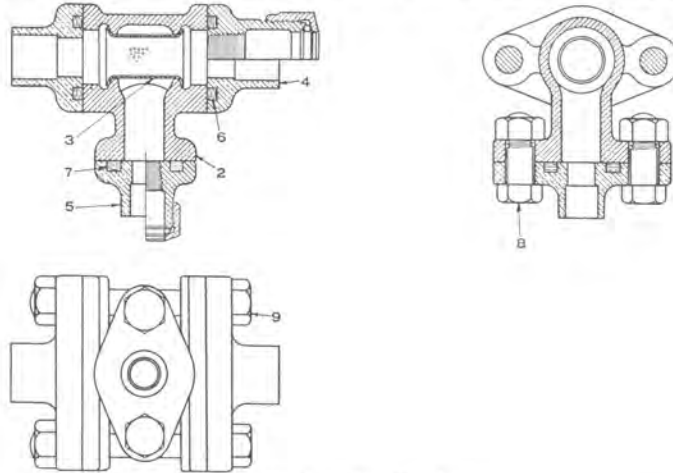

Approx. Net Wt. 5 1/4 Lbs.

	Complete Pc. No.	WABCOTITE FITTINGS (Pc. Nos.)			Remarks
		Signal Pipe		Branch Outlet	
		Inlet	Outlet		
3/8" OD x 1/8" OD x 5/8" OD	505331	502093	502093	503684	Fittings for Cop. Tube
3/4" IPS x 3/4" IPS x 5/8" OD	506237	505034	505034	503684	
1/2" IPS x 1/2" IPS x 5/8" OD	508806	508191	508191	503684	
3/4" x 3/4" x 1/2"	508580	93843	93843	93842	Fittings for Iron Pipe
3/4" x 3/4" x 3/8"	519958	93843	93843	505410	
3/4" x 3/4" x 5/8" OD	525622	93843	93843	503684	Sig. Pipe Fittings for Iron Pipe, Branch for Cop. Tube

Pc. No.	Ref. No.		Pc. No.	Ref. No.	
511309	2	Body with Strainer (includes 3)	503684	5	1/2" Wabcotite Sweat Fitting for 5/8" O.D. Cop. Tube (For Pcs. 505331, 506237, 508806 and 525622)
2242	3	Strainer	93842	5	1/2" Wabcotite Fitting for 1/2" Pipe, Complete (For Pc. 508580) (For details see P.C. 3216-21)
502093	4	3/4" Wabcotite Sweat Fitting for 3/8" O.D. Cop. Tube (2 Req'd for Pc. 505331)	505410	5	1/2" Wabcotite Fitting for 3/8" Pipe, Complete (For Pc. 519958) (For details see P.C. 3216-21)
505034	4	3/4" Wabcotite Sweat Fitting for 3/4" I.P.S. Cop. Tube (2 Req'd for Pc. 506237)	93841	6	3/4" Fitting Gasket (2 Req'd)
508191	4	3/4" Wabcotite Sweat Fitting for 1/2" I.P.S. Cop. Tube (2 Req'd for Pc. 508806)	94840	7	1/2" Fitting Gasket
93843	4	3/4" Wabcotite Fitting for 3/4" Pipe, Complete (2 Req'd for Pcs. 508580, 519958, and 525622) (For details see P.C. 3216-21)	506302	8	1/2" x 1 3/8" Bolt and Nut for Branch Outlet Fitting (2 Req'd)
			506304	9	1/2" x 3 7/8" Bolt and Nut for Signal Pipe Fittings (2 Req'd)

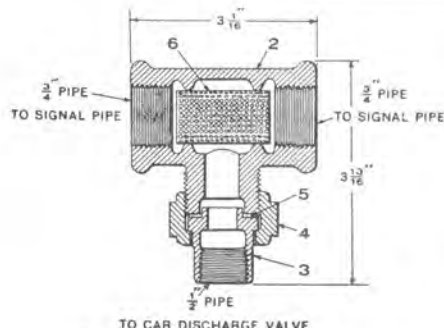

Approx. Net Wt. 1 7/16 Lbs.

SIGNAL PIPE STRAINER

Piece No. 2240 3/4" x 3/4" x 1/2" Signal Pipe Strainer, Complete

Piece No. 517681 3/4" x 3/4" x 5/8" OD Signal Pipe Strainer, complete

Pc. No.	Ref. No.	
2497	2	Strainer Body (includes 6)
2166	3	1/2" Union Swivel (for Pc. 2240)
505949	3	Union Swivel for 5/8" O.D. Tube (for Pc. 517681)
2165	4	1/2" Union Nut
81598	5	1/2" Union Gasket
2242	6	Strainer

Prices will be quoted upon application
Orders should give PIECE NUMBER and NAME of part wanted

BRAKE PIPE STRAINERS

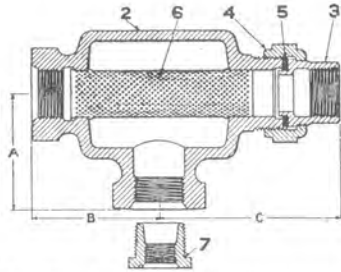

Dimensions and Net Weights

Size	A	B	C	Approx. Net Wt.
1 1/4"	2 7/8"	3 1/4"	4 5/8"	7 3/4 lbs.
1"	2 1/8"	3 1/4"	4 3/8"	6 lbs.
3/4"	2 3/4"	3 1/4"	4 7/16"	5 1/4 lbs.
1/2"	3"	3 1/8"	4 1/16"	6 lbs.

The Brake Pipe Air Strainer has been superseded by the Centrifugal Dirt Collector and is no longer furnished with full sets of Air Brake Equipment, unless specifically ordered.

Ref. No.		1 1/4"x1 1/4"x1 1/4"	1 1/4"x1 1/4"x1"	1 1/4"x1 1/4"x3/4"	1 1/4"x1 1/4"x1/2"	1 1/4"x1 1/4"x3/8"	1"x1"x1"	1"x1"x3/4"
	Brake Pipe Strainer, Complete	2151	14911	6141	6145	11496	2148	4989
2	Body (includes 6)	2182	2182	6142			2180	
2	Body (includes 6 and 7)				21780	21589		23603
3	Union Swivel	2155	2155	2155	2155	2155	1750	1750
4	Union Nut	2154	2154	2154	2154	2154	1749	1749
5	Union Gasket	91352	91352	91352	91352	91352	87726	87726
6	Strainer	2153	2153	2153	2153	2153	2150	2150
7	Reducing Bush		2178		9332	10089		6983

Ref. No.		1"x1"x1/2"	1"x1"x3/8"	3/4"x3/4"x3/4"	3/4"x3/4"x1/2"	3/4"x3/4"x3/8"	1/2"x1/2"x1/2"
	Brake Pipe Strainer, Complete	2179	10039	3310	11592	10088	11642
2	Body (includes 6)			3309			
2	Body (includes 6 and 7)	23604	23605		21590	23601	
2	Body (includes 6 and two of 7)						23602
3	Union Swivel	1750	1750	3307	3307	3307	3307
4	Union Nut	1749	1749	3306	3306	3306	3306
5	Union Gasket	87726	87726	87814	87814	87814	87814
6	Strainer	2150	2150	3305	3305	3305	3305
7	Reducing Bush	2181	10045		9332	10089	(3)9332

BRANCH PIPE STRAINERS

Ref. No.		1"	3/4"	1/2"	*1/2"
	Branch Pipe Strainer, Complete	9523	19824	18888	78246
2	Strainer Body	9522	2410	18887	78208
3	Strainer	2411	2411	2411	2411
4	Union Nut	1749	1749	1749	1749
5	Union Swivel	1750	19823	2412	2412
6	Union Gasket	87726	87726	87726	87726

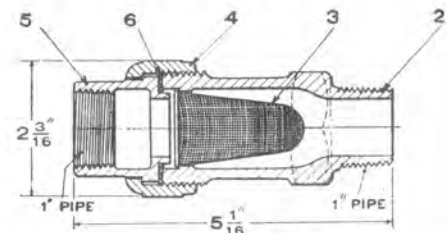

Approx. Net Weight 1 5/8 Lbs.

*NOTE—1/2" Branch Pipe Strainer, Pc. 78246, has Body tapped for 1/2" pipe, instead of threaded Body illustrated.

Prices will be quoted upon application
Orders should give PIECE NUMBER and NAME of part wanted

HOSE, COUPLINGS, FITTINGS

Parts Catalog No. 3216-3

November, 1956





Supersedes Issue of April, 1940





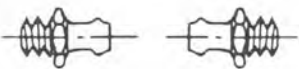
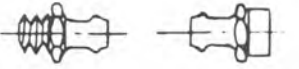
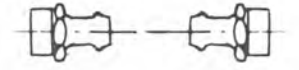
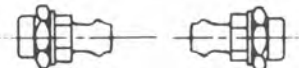
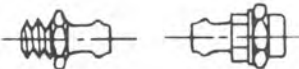
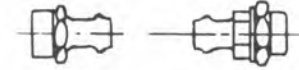
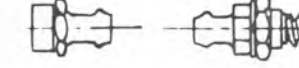
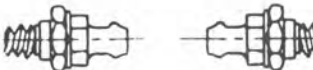
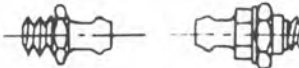

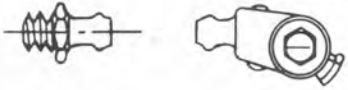
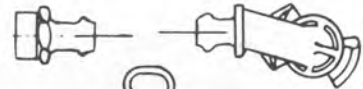
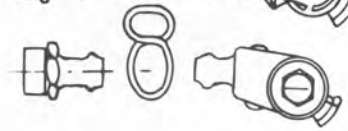

Westinghouse Air Brake
COMPANY

AIR BRAKE DIVISION  WILMERDING, PA.

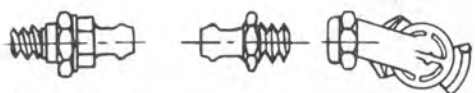
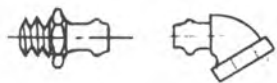
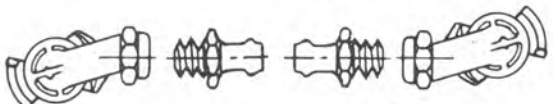
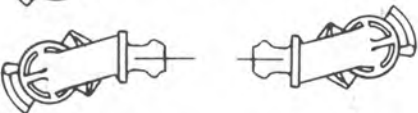
HOSE, COUPLINGS, FITTINGS

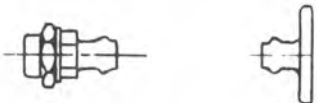
PICTURE TABULATION	DESCRIPTION	PAGE
	Hose with Threaded Nipples	4-7
	Hose with Threaded and Tapped Nipples	8
	Hose with Tapped Nipples	8
	Hose with Tapped Union Nipples	9-10
	Hose with Threaded Nipple and Tapped Union Nipple	11-14
	Hose with Tapped Nipple and Tapped Union Nipple	21-22
	Hose with Tapped Nipple and Threaded Union Nipple	20
	Hose with Threaded Union Nipples	14
	Hose with Threaded Nipple and Threaded Union Nipple	19-20
	Hose with Threaded Nipple and Hose Coupling	15-18
	Hose with "MK" Hose Coupling and Threaded Nipple	10
	Hose with Tapped Nipple and Hose Coupling (LP and FP Type).	22
	Hose with "MK" Coupling and Tapped Nipple	23
	Hose with Coupling and Tapped Union Nipple (AY, LP and FP Type)	23
	Hose with Threaded Nipples and Coupling (ES, HS, LS, EYS and FS Type)	30-31

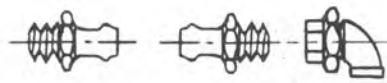
HOSE, COUPLINGS, FITTINGS

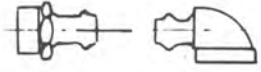
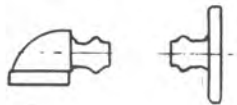
PICTURE TABULATION	DESCRIPTION	PAGE
	Hose with Threaded Union Nipple, Threaded Nipple and Coupling	24
	Hose with Tapped Angle Nipple and Threaded Nipple	24
	Hose with Two Threaded Nipples and Couplings	28
	Hose with Two Couplings	29
	Hose with Coupling and Tapped "EL" Flange Nipple	25
	Hose with Tapped Union Nipple and Straight Flange Fitting	24
	Hose with Two Straight Flange Fittings	25
	Hose with Threaded Nipples and Special Union Fitting	26
	Hose with Tapped Angle and Union Nipple	26
	Hose with Special Angle Flange Fittings, for WABCOTITE® Fittings	26
	Hose with Tapped Nipple and WABCOTITE "EL" Fittings	27
	Hose with WABCOTITE Angle Flange Fittings	27
	Standard Couplings	32-33
	EYS, OJ and ON	37
	Dust Stopper	36
	Couplings	35
	Dummy Couplings and Misc. Fittings	34
	Special Couplings	36
	Hose Fittings	38-39
	Angle Fittings with Reinforced Flange Union and Supporting Lug	40

HOSE WITH THREADED NIPPLES

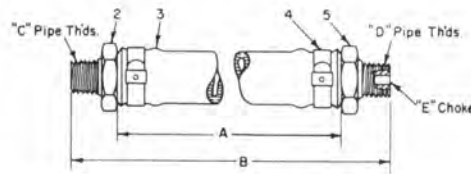

Diameter	Complete Pc. No.	Overall Length "B" inches	Fitting, Ref. 2		Hose, Ref. 3		Clamp Ref. 4	Fitting, Ref. 5		"C"	"D"	"E"
			Pc. No.	Size " inches	Pc. No.	Length "A"		Pc. No.	Size" inches			
1/4	67456	9-3/8	38021	1/4	544886	7	547779	38021	1/4	1/4-18	1/4-18	
	67458	13-3/8			544887	11						
	67457	15-3/8	38021	1/4	544888	13	547779	38021	1/4	1/4-18	1/4-18	
	549877	20-3/8			549876	18						
	54152	146-3/8			544890	144						
	38019	302-3/8	38021	1/4	544891	300	547779	38021	1/4	1/4-18	1/4-18	
3/8	549842	9-3/8	96826	1/4	549841	7	542883	96826	1/4	1/4-18	1/4-18	
	549843	17-3/8			544894	15						
	545975	24-3/8			31067	22						
	549844	26-3/8	96826	1/4	56440	24	542883	96826	1/4	1/4-18	1/4-18	
	549845	32-3/8			544896	30						
	539917	38-3/8			52695	36						
	539916	98-3/8	96826	1/4	96962	96		96826	1/4	1/4-18	1/4-18	
	51043	28-1/8	53975	3/8	56128	26	542883	53975	3/8	3/8-18	3/8-18	
	1/2	549846	12-1/4	6390	1/2	41301	10	547040	71979	3/8	1/2-14	3/8-18
517560		22-1/4			31218	20		71979	3/8		3/8-18	
531013		10-1/4	6390	1/2	21508	8		6390	1/2	1/2-14	1/2-14	
26123		21-1/4			26122	19		6390	1/2	1/2-14	1/2-14	
42131		24-1/4			45157	22		6390				
512494		24-1/4			45157	22		512493				3/16
542109		26-1/4			21507	24		6390				
542110		30-1/4			544903	28	547040		1/2	1/2-14	1/2-14	
6391		38-1/4			19576	36						
19578		44-1/4			19577	42						
59703		50-1/4			544907	48						
66271		62-1/4			48930	60						
66625		74-1/4			544910	72						
536282		98-1/4			58616	96						
27695		182-1/4			544912	180						
27694		302-1/4			544914	300						
47244		362-1/4	6390	1/2	544916	360						
67349		422-1/4			544918	420						
27693		602-1/4			544920	600						
26124		902-1/4			544922	900						
30713		1202-1/4			544923	1200		6390	1/2		1/2-14	
28026		302-3/8			544914	300		11514	3/4	1/2-14	3/4-14	
37108	482-3/8			544919	480		11514	3/4	1/2-14	3/4-14		
28392	602-3/8	6390	1/2	544920	600		11514	3/4	1/2-14	3/4-14		
64071	602-3/8	11514	3/4	544920	600		71979	3/8	3/4-14	3/8-18		
67472	602-3/8	11514	3/4	544920	600	547040	11514	3/4	3/4-14	3/4-14		

Prices will be quoted upon application

Orders should give PIECE NUMBER and NAME of part wanted

HOSE WITH THREADED NIPPLES (continued)

Diameter	Complete Pc. No.	Overall Length "B" inches	Fitting, Ref. 2		Hose, Ref. 3		Clamp Ref. 4	Fitting, Ref. 5		"C"	"D"	"E"
			Pc. No.	Size " inches	Pc. No.	Length "A"		Pc. No.	Size " inches			
5/8	541610	21-1/4	532838	1/2	544928	19	541051	532838	1/2	1/2-14	1/2-14	
	540585	24-1/4			544929	22						
	547091	26-1/4			547795	24						
	554370	28-1/4	532838	1/2	554227	26	541051	532838	1/2	1/2-14	1/2-14	
3/4	547666	10-5/8	547647	3/8	14487	8	541051	547647	3/8	3/8-18	3/8-18	
	547668	17-5/8			37734	15						
	547679	50-5/8	547647	3/8	544939	48	541051	547647	3/8	3/8-18	3/8-18	
3/4	25944	10-3/8	8417	1/2	14487	8	541051	8417	1/2	1/2-14	1/2-14	
	547667	15-3/8			19104	13						
	547669	18-3/8	8417		19886	16						
	547670	21-3/8	543138		21839	19						3/16"
	547671	22-3/8	8417		19179	20						
	8641	24-3/8	8417		8643	22						
	545451	24-3/8	543138		8643	22						3/16"
	547672	26-3/8	543138		33289	24						3/16"
	543001	27-3/8	8417	1/2	35422	25	541051	8417	1/2	1/2-14	1/2-14	
	547674	27-3/8	543138		35422	25						3/16"
	543002	28-3/8	543138		21883	26						3/16"
	547680	28-3/8	8417		21883	26						
	547675	29-3/8			19300	27						
	547662	31-3/8	8417		547665	29						
	547676	32-3/8	543138		20092	30						3/16"
	543000	32-3/8	8417		20092	30						
	547678	33-3/8			544934	31						
	542927	36-3/8	8417		49389	34						
	543003	36-3/8	543138		49389	34						3/16"
	72820	38-3/8	8417		19316	36						
549772	58-3/8	8417	1/2	37696	56	541051	8417	1/2	1/2-14	1/2-14		
3/4	547673	26-3/8	543138	1/2	33289	24	541051	7968	3/4	1/2-14	3/4-14	3/16"
	543004	26-3/8	8417		33289	24						
	547677	32-3/8	8417		20092	30						
	543005	32-3/8	543138	1/2	20092	30	541051	7968	3/4	1/2-14	3/4-14	3/16"
3/4	519385	12-3/8	7968	3/4	20101	10	541051	7968	3/4	3/4-14	3/4-14	
	554074	17-3/8			37734	15						
	45525	22-3/8			19179	20						
	21549	24-3/8			8643	22						
	25789	28-3/8			21883	26						
	549267	29-3/8			19300	27						
	25750	30-3/8			22155	28						
	543409	32-3/8	7968	3/4	20092	30	541051	7968	3/4	3/4-14	3/4-14	
	548534	35-3/8			544936	33						
	8648	38-3/8			19316	36						
	21488	47-3/8			21489	45						
	546425	50-3/8			544939	48						
	42363	110-3/8			544947	108						
	520561	122-3/8			35424	120						
	21305	602-3/8			544953	600						
	548532	26-3/8	7968	3/4	33289	24	541051	7968	3/4	3/4-14	3/4-14	

Prices will be quoted upon application

Orders should give PIECE NUMBER and NAME of part wanted

HOSE WITH THREADED NIPPLES (continued)

Diameter	Complete Pc. No.	Overall Length "B" inches	Fitting, Ref. 2		Hose, Ref. 3		Clamp Ref. 4	Fitting, Ref. 5		"C"	"D"	"E"								
			Pc. No.	Size "	Pc. No.	Length "A" inches		Pc. No.	Size "											
3/4	548533	27-3/8	7968	3/4	35422	25	541051	47811	1	3/4-14	1-11-1/2									
	550361	50-7/8			544939	48														
	550594	68-7/8			544945	66														
	550595	146-7/8	7968	3/4	51276	144	541051	47811	1	3/4-14	1-11-1/2									
3/4	68495	24-7/8	7968	3/4	8643	22	541051	47811	1	3/4-14	1-11-1/2									
7/8	547090	22-3/8	532839	3/4	547801	20	541051	532839	3/4	3/4-14	3/4-14									
	547093	26-3/8			544957	24														
	546835	27-3/8	532839	3/4	546387	25	541051	532839	3/4	3/4-14	3/4-14									
1-1/8	90924	9	46169	3/4	544962	6	539322	46169	3/4	3/4-14	3/4-14									
	516188	11			5089	8														
	547732	16			56441	13														
	546348	19			23002	16														
	90925	20			19416	17														
	97856	21			19275	18														
	536353	23			20890	20														
	542982	24			41310	21														
	46684	25			545022	22														
	542983	26			46169	3/4		544963	23				539322	46169	3/4	3/4-14	3/4-14			
	68558	27			18282	24														
	542980	28			544964	25														
	547338	29			20438	26														
	73539	31			19450	28														
	547733	32			65594	29														
	533921	33			19539	30														
	542981	36			544967	33														
	58793	39			4893	36														
	46685	48			35419	45														
	80519	51			21456	48														
536281	99	46169	3/4	544970	96	539322	46169	3/4	3/4-14	3/4-14										
1-1/8	46661	25-5/8	46175	1	545022	22	539322	46169	3/4	1-11-1/2	3/4-14									
	46662	39-5/8	46175	1	4893	36	539322	46169	3/4	1-11-1/2	3/4-14									
1-1/8	513264	11-5/8	46175	1	5089	8	539322	46175	1	1-11-1/2	1-11-1/2									
	66062	12-5/8			545102	9														
	46679	15-5/8			19144	12														
	507587	16-5/8			56441	13														
	46680	18-5/8			21332	15														
	46682	22-5/8			20373	19														
	542976	23-5/8			46175	1							20890	20	539322	46175	1	1-11-1/2	1-11-1/2	
	46683	25-5/8			545022	22														
	547618	26-5/8			544963	23														
	46681	27-5/8			18282	24														
	549252	31-5/8			19450	28														
	542975	32-5/8			65594	29														
	542926	37-5/8			49388	34														
	50012	39-5/8			46175	1							4893	36	539322	46175	1	1-11-1/2	1-11-1/2	

Prices will be quoted upon application

Orders should give PIECE NUMBER and NAME of part wanted

HOSE WITH THREADED NIPPLES (continued)

Diameter	Complete Pc. No.	Overall Length "B" inches	Fitting, Ref. 2		Hose, Ref. 3		Clamp Ref. 4	Fitting, Ref. 5		"C"	"D"			
			Pc. No.	Size" inches	Pc. No.	Length "A" inches		Pc. No.	Size" inches					
1-1/8	547734	48-5/8	46175	1	35419	45	539322	46175	1	1-11-1/2	1-11-1/2			
	549774	59-5/8			549778	56								
	58027	63-5/8			30469	60								
	68472	66-5/8	46175	1	21289	63		539322	46175			1	1-11-1/2	1-11-1/2
1-3/8	58683	17-1/2	46272	1	22716	14	539321	46272	1	1-11-1/2	1-11-1/2			
	47102	39-1/2			29089	36								
	73837	63-1/2	46272	1	33530	60		539321	46272			1	1-11-1/2	1-11-1/2
1-3/8	90906	11-5/8	46223	1-1/4	24832	8	539321	46223	1-1/4	1-1/4-11-1/2	1-1/4-11-1/2			
	47087	13-5/8			35421	10								
	554866	14-5/8			555009	11								
	47094	17-5/8			22716	14								
	547759	21-5/8			21233	18								
	547092	22-5/8			19311	19								
	47088	23-5/8			20303	20								
	49829	24-5/8			44872	21								
	47085	25-5/8			545023	22								
	545512	25-5/8			545023	22								
	547760	26-5/8			50140	23								
	47086	27-5/8			20638	24								
	549266	29-5/8			19608	26								
	547761	30-5/8			544976	27								
	524464	32-5/8	46223	1-1/4	544977	29		539321	46223			1-1/4	1-1/4-11-1/2	1-1/4-11-1/2
	86734	33-5/8			21705	30								
	542990	35-5/8			544978	32								
	47089	39-5/8			29089	36								
	47092	41-5/8			41316	38								
	47093	44-5/8			41317	41								
	547762	48-5/8			35420	45								
47091	49-5/8			41315	46									
55467	54-5/8			55468	51									
47090	57-5/8			31732	54									
529865	63-5/8			33530	60									
528365	66-5/8			544984	63									
518907	75-5/8	46223	1-1/4	41314	72	539321	46223	1-1/4	1-1/4-11-1/2	1-1/4-11-1/2				
1-3/8	541668	25-5/8	82998	1-1/2	545023	22	539321	82998	1-1/2	1-1/2-11-1/2	1-1/2-11-1/2			

Prices will be quoted upon application

Orders should give PIECE NUMBER and NAME of part wanted

HOSE WITH THREADED AND TAPPED NIPPLES

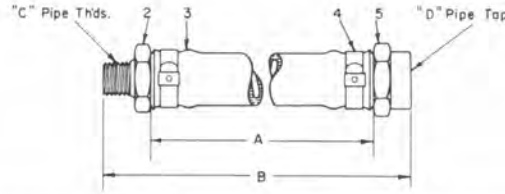

Diameter	Complete Pc. No.	Overall Length "B" inches	Fitting, Ref. 2		Hose, Ref. 3		Clamp Ref. 4	Fitting, Ref. 5		"C"	"D"
			Pc. No.	Size inches	Pc. No.	Length "A" inches		Pc. No.	Size inches		
3/8	518074	13	53975	3/8	544892	11	542883	57116	3/8	3/8-18	3/8-18
1/2	44319	242-1/2	6390	1/2	544913	240	547040	44277	1/2	1/2-14	1/2-14
3/4	515595	10-1/4	7968	3/4	14487	8	541051	14773	3/4	3/4-14	3/4-14
	99568	13-1/4	7968	3/4	41305	11	541051	14773	3/4	3/4-14	3/4-14
	515258	14-1/4	7968	3/4	19180	12	541051	14773	3/4	3/4-14	3/4-14
1-1/8	96030	14-5/8	46169	3/4	19144	12	539322	46178	3/4	3/4-14	3/4-14
	64493	18-5/8	46169	3/4	23002	16	539322	46178	3/4	3/4-14	3/4-14
1-1/8	57117	19	46175	1	23002	16	539322	46178	3/4	1-11-1/2	3/4-14
1-1/8	501531	12	46175	1	545102	9	539322	46180	1	1-11-1/2	1-11-1/2
	72007	14			545103	11					
	56347	19			23002	16					
	56345	25	46175	1	545022	22	539322	46180	1	1-11-1/2	1-11-1/2
	58626	29			20438	26					
	56346	37			49388	34					
	82947	40	46175	1	544968	37	539322	46180	1	1-11-1/2	1-11-1/2
1-3/8	554378	33-3/16	532825	1-1/4	554403	31	539321	46273	1-1/4	1-1/4-11-1/2	

HOSE WITH TAPPED NIPPLES

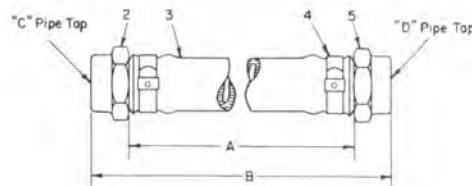

Diameter	Complete Pc. No.	Overall Length "B" inches	Fitting, Ref. 2		Hose, Ref. 3		Clamp Ref. 4	Fitting, Ref. 5		"C"	"D"
			Pc. No.	Size inches	Pc. No.	Length "A" inches		Pc. No.	Size inches		
1/4	79546	121-1/4	79533	1/4	544889	120	547779	79533	1/4	1/4-18	1/4-18
3/8	512575	16-3/4	57116	3/8	544894	15	542883	57116	3/8	3/8-18	3/8-18
	512518	25-3/4	57116	3/8	56440	24	542883	57116	3/8	3/8-18	3/8-18
	512519	31-3/4	57116	3/8	544896	30	542883	57116	3/8	3/8-18	3/8-18
7/8	550547	20	532837	3/4	544955	18	541052	532837	3/4	3/4-14	3/4-14

Prices will be quoted upon application

Orders should give PIECE NUMBER and NAME of part wanted

HOSE WITH TAPPED UNION NIPPLES

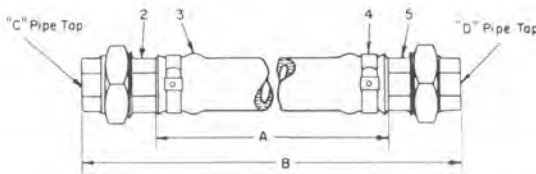

Diameter	Complete Pc. No.	Overall Length "B" inches	Fitting, Ref. 2		Hose, Ref. 3		Clamp Ref. 4	Fitting, Ref. 5		"C"	"D"
			Pc. No.	Size inches	Pc. No.	Length "A" inches		Pc. No.	Size inches		
1/2	545342	10-1/8	544805	1/4	8979	7	547040	544805	1/4	1/4-18	1/4-18
1/2	545343	11-1/2	544804	3/8	21508	8	547040	544804	3/8	3/8-18	3/8-18
	545344	27-1/2	544804	3/8	21507	24	547040	544804	3/8	3/8-18	3/8-18
1/2	545345	63-7/8	544806	1/2	48930	60	547040	544806	1/2	1/2-14	1/2-14
	545346	69-7/8			544908	66					
	545347	75-7/8			544910	72					
	545348	147-7/8			544911	144					
	545349	243-7/8	544806	1/2	544913	240	547040	544806	1/2	1/2-14	1/2-14
	545350	303-7/8			544914	300					
	546380	369-7/8			546383	366					
	549195	396-7/8			549220	393					
	547481	455-7/8			547479	452					
	545351	483-7/8	544806	1/2	544919	480	547040	544806	1/2	1/2-14	1/2-14
3/4	545352	11-7/8	544808	1/2	14487	8	541051	544808	1/2	1/2-14	1/2-14
	545355	25-7/8			8643	22					
	545357	33-7/8	544808	1/2	20092	30	541051	544808	1/2	1/2-14	1/2-14
	545361	57-7/8			544943	54					
	556188	72-7/8			556187	69					
	547491	75-7/8	544808	1/2	544946	72	541051	544808	1/2	1/2-14	1/2-14
3/4	545353	22-1/2	541765	3/4	19306	18	541051	541765	3/4	3/4-14	3/4-14
	545354	26-1/2			8643	22					
	545358	52-1/2			544939	48					
	545359	55-1/2			544940	51					
	545360	57-1/2			544942	53					
	545362	64-1/2			35365	60					
	546379	67-1/2	541765	3/4	546381	63	541051	541765	3/4	3/4-14	3/4-14
	545363	124-1/2			35424	120					
	545364	127-1/2			544948	123					
	545365	304-1/2			544951	300					
	546378	367-1/2			546382	363					
	547480	456-1/2			547478	452					
	549194	396-1/2	541765	3/4	549221	392	541051	541765	3/4	3/4-14	3/4-14
	555499	544-1/2	541765	3/4	555498	540		541765	3/4	3/4-14	3/4-14
3/4	545356	34-1/2	544807	1	22155	28	541051	544807	1	1-11-1/2	1-11-1/2
1-1/8	545373	26-1/2	544812	1/2	545022	22	539322	544812	1/2	1/2-14	1/2-14
	545375	28-1/2			18282	24					
	545376	30-1/2			20438	26					
	545378	34-1/2	544812	1/2	19539	30	539322	544812	1/2	1/2-14	1/2-14
	545379	39-1/2			29161	35					
	545381	44-1/2			19924	40					
	546925	52-1/2	544812	1/2	21456	48	539322	544812	1/2	1/2-14	1/2-14

Prices will be quoted upon application

Orders should give PIECE NUMBER and NAME of part wanted

HOSE WITH TAPPED UNION NIPPLES (continued)

Diameter	Complete Pc. No.	Overall Length "B" inches	Fitting, Ref. 2		Hose, Ref. 3		Clamp Ref. 4	Fitting, Ref. 5		"C"	"D"
			Pc. No.	Size inches	Pc. No.	Length "A" inches		Pc. No.	Size inches		
1-1/8	545366	11-3/8	544810	3/4	17910	7	539322	544810	3/4	3/4-14	3/4-14
	545368	12-3/8			5089	8					
	545369	16-3/8			19144	12					
	545370	22-3/8			19275	18					
	545372	26-3/8			545022	22					
	545377	34-3/8		544810	3/4	19539	30	539322	544810	3/4	3/4-14
1-1/8	545367	12-7/8	544814	1	5089	8	539322	544814	1	1-11-1/2	1-11-1/2
	545371	26-7/8			545022	22					
	545374	28-7/8			18282	24					
	545380	44-7/8			19924	40					
	545382	52-7/8	544814	1	21456	48	539322	544814	1	1-11-1/2	1-11-1/2
	545383	61-7/8			45615	57					
	545384	64-7/8			30469	60					
	545385	76-7/8			544982	72					
	545386	130-7/8		544814	1	545105	126	539322	544814	1	1-11-1/2
1-3/8	545387	17-1/2	547960	1-1/4	19445	12	539321	547960	1-1/4	1-1/4-11-1/2	1-1/4-11-1/2
	545388	27-1/2			545023	22					
	545389	53-1/2	547960	1-1/4	544983	48	539321	547960	1-1/4	1-1/4-11-1/2	1-1/4-11-1/2
	545390	77-1/2			41314	72					
	545391	87-1/2		547960	1-1/4	25553	82	539321	547960	1-1/4	1-1/4-11-1/2

HOSE WITH "MK" HOSE COUPLING AND THREADED NIPPLE

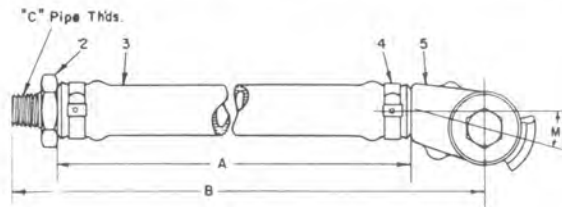

Diameter	Complete Pc. No.	Overall Length "B" inches	Fitting, Ref. 2		Hose, Ref. 3		Clamp Ref. 4	Fitting, Ref. 5		"C"	Offset ° "M"
			Pc. No.	Size inches	Pc. No.	Length "A" inches		Pc. No.	Type		
3/4	545152	23-3/4	7968	3/4	21839	19	541051	96892	MK-3	3/4-14	+15
	96865	29-3/4	7968	3/4	35422	25	541051	96892	MK-3	3/4-14	+15
1-1/8	528490	28-3/4	46190	3/4	18282	24	539322	46344	MK-4	3/4-14	+15
1-1/8	47074	22-3/4	46175	1	19275	18	539322	46344	MK-4	1-11-1/2	+15
	47073	24-3/4	46175	1	20890	20	539322	46344	MK-4	1-11-1/2	+15
	47072	26-3/4	46175	1	545022	22	539322	46344	MK-4	1-11-1/2	+15

Prices will be quoted upon application

Orders should give PIECE NUMBER and NAME of part wanted

HOSE WITH THREADED NIPPLE AND TAPPED UNION NIPPLE

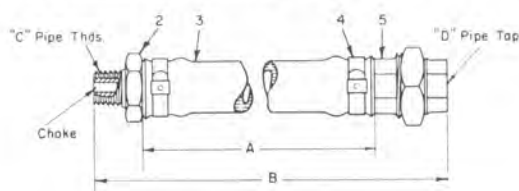

Diameter	Complete Pc. No.	Overall Length "B" inches	Fitting, Ref. 2		Hose, Ref. 3		Clamp Ref. 4	Fitting, Ref. 5		"C"	"D"	
			Pc. No.	Size inches	Pc. No.	Length "A" inches		Pc. No.	Size inches			
3/8	545237	8-3/4	53975	3/8	10855	6	542883	544803	3/8	3/8-18	3/8-18	
	545238	14-3/4			544893	12						
	545239	15-3/4			54482	13						
	545240	23-3/4			544895	21						
	545241	26-3/4			56440	24						
	545242	27-3/4	53975	3/8	545100	25	542883	544803	3/8	3/8-18	3/8-18	
	545243	30-3/4			516204	28						
	545244	35-3/4			544897	33						
	545245	38-3/4			52695	36						
	545246	42-3/4			544898	40						
	545247	45-3/4			52556	43						
	545248	62-3/4	53975	3/8	544899	60	542883	544803	3/8	3/8-18	3/8-18	
	554085	80-3/4			554087	78						
	555831	134-3/4	53975	3/8	555836	132	542883	544803	3/8	3/8-18	3/8-18	
1/2	545250	14-7/8	71979	3/8	544900	12	547040	544804	3/8	3/8-18	3/8-18	
	545252	21-7/8			26122	19						
	545256	30-7/8			544903	28						
	545260	36-7/8	71979	3/8	510910	34				3/8-18		
	545263	62-7/8	6390	1/2	48930	60	547040	544804	3/8	1/2-14	3/8-18	
	545268	410-1/8	6390	1/2	544917	408		544804	3/8	1/2-14	3/8-18	
	1/2	545249	13-1/8	6390	1/2	41301	10	547040	544806	1/2	1/2-14	1/2-14
		545251	16-1/8			41302	13					
		546110	22-1/8			26122	19					
		545253	25-1/8			45157	22					
545254		27-1/8			21507	24						
545255		29-1/8			41303	26						
545257		32-1/8	6390		47844	29						
545258		32-1/8	80003	*	47844	29						
545259		36-1/8	6390		47845	33						
545261		42-1/8		1/2	544906	39	547040	544806	1/2	1/2-14	1/2-14	
545262		63-1/8			48930	60						
545264		183-1/8			544912	180						
545265		243-1/8			544913	240						
545266		303-1/8			544914	300						
545267	363-1/8			544916	360							
545269	483-1/8			544919	480							
545270	603-1/8			544920	600							
545271	723-1/8			544921	720							
545272	903-1/8	6390	1/2	544922	900	547040	544806	1/2	1/2-14	1/2-14		

*Note: Nipple with 3/32" Choke

Prices will be quoted upon application

Orders should give PIECE NUMBER and NAME of part wanted

HOSE WITH THREADED NIPPLE AND TAPPED UNION NIPPLE
(continued)

Diameter	Complete Pc. No.	Overall Length "B" inches	Fitting, Ref. 2		Hose, Ref. 3		Clamp Ref. 4	Fitting, Ref. 5		"C"	"D"
			Pc. No.	Size inches	Pc. No.	Length "A" inches		Pc. No.	Size inches		
5/8	546206	18-1/8	532838	1/2	546208	15	541051	533446	1/2	1/2-14	1/2-14
	548570	25-1/8			544929	22					
	546834	50-1/8	532838	1/2	546832	47	541051	533446	1/2	1/2-14	1/2-14
5/8	550110	18-1/8	550107	3/4	546208	15	541051	533446	1/2	3/4-14	1/2-14
3/4	545275	14-1/8	8417	1/2	41305	11	541051	544808	1/2	1/2-14	1/2-14
	545281	19-1/8			19886	16					
	545284	25-1/8			8643	22					
	545289	29-1/8			21883	26					
	547698	31-1/8			22155	28					
	545293	33-1/8			20092	30					
	545296	35-1/8	8417	1/2	544935	32	541051	544808	1/2	1/2-14	1/2-14
	545298	39-1/8			19316	36					
	545300	43-1/8			27767	40					
	545302	50-1/8			544938	47					
	547633	52-1/8			547642	49					
	545306	63-1/8	8417	1/2	35365	60	541051	544808	1/2	1/2-14	1/2-14
3/4	545308	603-1/2	8417	1/2	544953	600	541051	541765	3/4	1/2-14	3/4-14
3/4	545273	12-1/2	7968	3/4	28644	9	541051	541765	3/4	3/4-14	3/4-14
	545274	13-1/2			20101	10					
	545276	15-1/2			19180	12					
	545277	16-1/2			19104	13					
	545278	17-1/2			30975	14					
	545279	18-1/2			37734	15					
	545280	19-1/2			19886	16					
	545282	21-1/2			19306	18					
	545283	25-1/2			8643	22					
	545286	27-1/2			33289	24					
	545287	28-1/2	7968	3/4	35422	25	541051	541765	3/4	3/4-14	3/4-14
	545288	29-1/2			21883	26					
	545290	31-1/2			22155	28					
	545292	33-1/2			20092	30					
	545295	34-1/2			544934	31					
	545297	39-1/2			19316	36					
	545299	43-1/2			27767	40					
	545301	47-1/2			53497	44					
	545303	51-1/2			544939	48					
	545304	53-1/2			35423	50					
545305	57-1/2			544943	54						
545307	147-1/2	7968	3/4	51276	144	541051	541765	3/4	3/4-14	3/4-14	
3/4	545285	26-1/2	7968	3/4	8643	22	541051	544807	1"	3/4-14	1-11-1/2
	545294	34	47811	1"	20092	30	541051	544807	1"	1-11-1/2	1-11-1/2
7/8	546205	18-1/2	532839	3/4	546207	15	541052	533508	3/4	3/4-14	3/4-14
	546391	25-1/2	532839	3/4	544956	22	541052	533508	3/4	3/4-14	3/4-14
1-1/8	546898	25-3/4	46169	3/4	545022	22	539322	544812	1/2	3/4-14	1/2-14
1-1/8	546891	10-3/4	46169	3/4	17910	7	539322	544810	3/4	3/4-14	3/4-14
	546892	19-3/4			23002	16					
	546893	21-3/4	46169	3/4	19275	18	539322	544810	3/4	3/4-14	3/4-14

Prices will be quoted upon application

Orders should give PIECE NUMBER and NAME of part wanted

HOSE WITH THREADED NIPPLE AND TAPPED UNION NIPPLE
(continued)

Diameter	Complete Pc. No.	Overall Length "B" inches	Fitting, Ref. 2		Hose, Ref. 3		Clamp Ref. 4	Fitting, Ref. 5		"C"	"D"	
			Pc. No.	Size inches	Pc. No.	Length "A" inches		Pc. No.	Size inches			
1-1/8	546895	22-3/4	46169	3/4	20373	19	539322	544810	3/4	3/4-14	3/4-14	
	546896	25-3/4			545022	22						
	547632	26-3/4			544963	23						
	546899	27-3/4			18282	24						
	547736	28-3/4			544964	25						
	546900	31-3/4	46169	3/4	19450	28	539322	544810	3/4	3/4-14	3/4-14	
	546901	33-3/4			19539	30						
	547737	34-3/4			544966	31						
	546902	35-3/4			55861	32						
	546904	39-3/4			4893	36						
	546907	41-3/4			544969	38						
	546909	45-3/4			30355	42						
	546910	47-3/4			41034	44						
	547738	48-3/4			35419	45						
	546911	51-3/4	46169	3/4	21456	48	539322	544810	3/4	3/4-14	3/4-14	
	1-1/8	545309	12-1/4	46175	1	5089	8	539322	544814	* 1	1-11-1/2	1-11-1/2
545310		14-1/4			19377	10		544814				
547473		16-1/4			19144	12		546877				
545311		16-1/4			19144	12		544814				
545312		17-1/4			56441	13						
545313		18-1/4			20098	14						
545314		19-1/4			21332	15		544814				
547474		19-1/4			21332	15		546877				
545315		20-1/4			23002	16		544814				
545316		21-1/4			19416	17						
545317		22-1/4			19275	18						
545318		23-1/4			20373	19		544814				
546915		25-1/4			41310	21		546877				
545319		26-1/4			545022	22		544814				
546879		26-1/4	46175	1	93301	22	539322	546877	1	1-11-1/2	1-11-1/2	
547735		27-1/4			544963	23		544814				
547475		31-1/4			544965	27		546877				
545320		34-1/4			19539	30		544814				
546880		38-1/4			93300	34		546877				
545321		38-1/4			49388	34		544814				
546903		40-1/4			4893	36		544814				
546906		41-1/4			544968	37		544814				
546908		46-1/4			30355	42		544814				
547476		46-1/4			30355	42		546877				
547739		49-1/4			35419	45		544814				
546912		54-1/4			544981	50		544814				
546913		58-1/4			31730	54		544814				
546914		64-1/4	46175	1	30469	60	539322	544814	1	1-11-1/2	1-11-1/2	
1-1/8		546894	22-1/4	46164	1-1/4	19275	18	539322	544814	1	1-1/4-11-1/2	1-11-1/2
		546897	26-1/4	46164	1-1/4	545022	22	539322	544814	1	1-1/4-11-1/2	1-11-1/2
1-1/8	546905	40-1/4	46164	1-1/4	4893	36	539322	544815	1-1/4	1-1/4-11-1/2	1-1/4-11-1/2	

*NOTE - Nipple Pc. No. 544814 is an AAR recommended Nipple.

Prices will be quoted upon application

Orders should give PIECE NUMBER and NAME of part wanted

HOSE WITH THREADED NIPPLE AND TAPPED UNION NIPPLE

(continued)

Diameter	Complete Pc. No.	Overall Length "B" inches	Fitting, Ref. 2		Hose, Ref. 3		Clamp Ref. 4	Fitting, Ref. 5		"C"	"D"
			Pc. No.	Size inches	Pc. No.	Length "A" inches		Pc. No.	Size inches		
1-3/8	545325	26-1/8	46272	1	545023	22	539321	544816	* 1	1-11-1/2	1-11-1/2
	545328	40-1/8	46272	1	29089	36	539321	544816	1	1-11-1/2	1-11-1/2
1-3/8	545322	13-5/8	46223	1-1/4	544975	9	539321	547960	1-1/4	1-1/4-11-1/2	1-1/4-11-1/2
	545323	16-5/8			19445	12					
	545324	26-5/8			545023	22					
	547754	27-5/8			50140	23					
	547755	29-5/8			41313	25					
	545326	34-5/8			21705	30					
	545327	40-5/8	46223	1-1/4	29089	36	539321	547960	1-1/4	1-1/4-11-1/2	1-1/4-11-1/2
	547756	41-5/8			544979	37					
	545329	46-5/8			30357	42					
	545330	48-5/8			54859	44					
	547757	49-5/8			35420	45					
	547758	50-5/8			41315	46					
	545331	58-5/8	46223	1-1/4	31732	54	539321	547960	1-1/4	1-1/4-11-1/2	1-1/4-11-1/2

* Note: Nipple Pc. 544816 is an AAR recommended Nipple.

HOSE WITH THREADED UNION NIPPLES

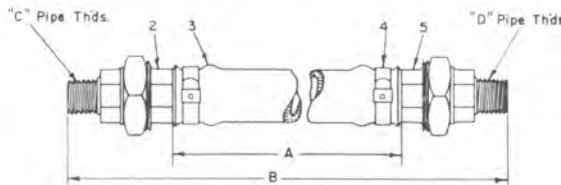

Diameter	Complete Pc. No.	Overall Length "B" inches	Fitting, Ref. 2		Hose, Ref. 3		Clamp Ref. 4	Fitting, Ref. 5		"C"	"D"
			Pc. No.	Size inches	Pc. No.	Length "A" inches		Pc. No.	Size inches		
3/4	545402	59-3/8	545657	1/2	544943	54	541051	545657	1/2	1/2-14	1/2-14
3/4	545686	54-1/4	534318	3/4	544939	48	541051	534318	3/4	3/4-14	3/4-14
1-1/8	545403	60-1/8	544811	3/4	31730	54	539322	544811	3/4	3/4-14	3/4-14
	536815	54-3/4	534317	1	21456	48	539322	534317	1	1-11-1/2	1-11-1/2
1-3/8	536814	55-1/2	537003	1-1/4	544983	48	539321	537003	1-1/4	1-1/4-11-1/2	1-1/4-11-1/2

Prices will be quoted upon application

Orders should give PIECE NUMBER and NAME of part wanted

HOSE WITH THREADED NIPPLE AND HOSE COUPLING

3216-3

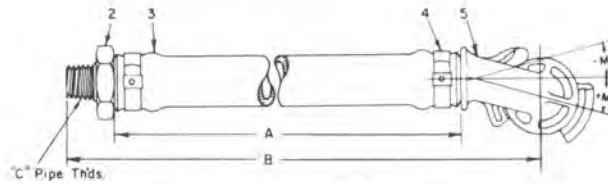

Diameter	Complete Pc. No.	Overall Length "B" inches	Fitting, Ref. 2		Hose, Ref. 3		Clamp Ref. 4	Fitting, Ref. 5		"C"	Offset ° "M"
			Pc. No.	Size inches	Pc. No.	Length "A" inches		Pc. No.	Type		
1/2	70728		71979	3/8	544914	300	547040	22577	AY-2	3/8	
1/2			6390	1/2	544900	12	547040	22577	AY-2	1/2	
	69114				544901	18					
	42455				45157	22					
	52004				21507	24					
	49399				48930	60					
	28426				545101	120					
	37212				544912	180					
	35093				544913	240	547040	22577	AY-2	1/2	
	31220		6390	1/2	544914	300					
	70728				544914	300					
	22928				544915	336					
	66007				544916	360					
	35279				544920	600					
	22929				544922	900					
	63149				544923	1200					
	35416				544925	1620					
	65089										
	83612		6390	1/2	544926	2400	547040	22577	AY-2	1/2	
3/4	18719		7968	3/4	48747	21	541051	11459	AL-2	3/4	
	22360		21458	7/8	35424	120				7/8	
	21200				544949	180					
	20867				545106	360					
	20950		21458	7/8	544953	600	541051	11459	AL-2	7/8	
3/4	20100	13-5/8	7968	3/4	20101	10	541051	518015	LP-3	3/4	-20
	35043	14-5/8			41305	11		518015	LP-3		-20
	33480	15-5/8			19180	12		518015	LP-3		-20
	545682	17-5/8			30975	14		11122	EP-3		+20
	30976	17-5/8			30975	14		518015	LP-3		-20
	542858	19-5/8			19886	16		11122	EP-3		+20
	19441	20-5/8			19442	17		518015	LP-3		-20
	45505	21-5/8			19306	18		518015	LP-3		-20
	32181	21-5/8			19306	18		11122	EP-3		+20
	23003	22-5/8			21839	19		518015	LP-3		-20
	47483	23-5/8			19179	20		518015	LP-3		-20
	35306	23-5/8			19179	20		11122	EP-3		+20
	32081	25-5/8			8643	22		11122	EP-3		+20
	32091	25-5/8			8643	22		518015	LP-3		-20
	32077	26-1/8			8643	22		10710	FP-3		+15
	80883	29-5/8	7968	3/4	21883	26	541051	518015	LP-3	3/4	-20
	20344	30-5/8			19300	27		518015	LP-3		-20
	19629	31-5/8			22155	28		11122	EP-3		+20
	30359	33-5/8	7968	3/4	20092	30	541051	11122	EP-3	3/4	+20

Prices will be quoted upon application

Orders should give PIECE NUMBER and NAME of part wanted

HOSE WITH THREADED NIPPLE AND HOSE COUPLING (continued)

Diameter	Complete Pc. No.	Overall Length "B" inches	Fitting, Ref. 2		Hose, Ref. 3		Clamp Ref. 4	Fitting, Ref. 5		"C"	Offset ^o "W"
			Pc. No.	Size inches	Pc. No.	Length "A" inches		Pc. No.	Type		
3/4	48928	33-5/8	7968	3/4	20092	30	541051	518015	LP-3	3/4	-20
	533596	35-5/8			544935	32		11122	EP-3		+20
	49391	37-5/8			49389	34		518015	LP-3		-20
	58314	39-5/8			19316	36		518015	LP-3		-20
	21758	39-5/8	7968	3/4	19316	36	541051	11122	EP-3		+20
	19707	41-5/8			19708	38		11122	EP-3		+20
	20720	42-5/8			20721	39		11122	EP-3		+20
	29994	42-5/8			20721	39		518015	LP-3		-20
	35415	43-5/8			27767	40		11122	EP-3		+20
	31962	44-5/8			20898	41		11122	EP-3		+20
	19706	45-5/8			9890	42		11122	EP-3		+20
	29993	46-5/8		7968	3/4	29992	43	541051	11122	EP-3	3/4
540914	49-5/8				544937	46		518015	LP-3		-20
540915	49-5/8				544937	46		11122	EP-3		+20
42378	51-5/8		7968	3/4	544939	48	541051	11122	EP-3	3/4	+20
3/4	33987	64-1/8	8417	1/2	35365	60	541051	10710	FP-3	1/2	+15
3/4	53616	63-5/8	7968	3/4	35365	60	541051	11122	EP-3	3/4	+20
3/4	58315	26-1/8	47811	1	8643	22	541051	518015	LP-3	1	-20
1-1/8	71431	19-3/8	46169	3/4	21332	15	539322	46102	HP-4	3/4-14	+15
	47078	19-3/4			23002	16		88991	LP-4		-20
	71170	20-3/8			23002	16		46102	HP-4		+15
	46596	21-3/8			19416	17		86784	FP-4		+15
	46255	21-3/8			19416	17		46102	HP-4		+15
	58316	22-3/8			19275	18		46102	HP-4		+15
	99543	22-3/8			19275	18		86760	HP-4		+15
	66873	23-3/8			20373	19		86784	FP-4		+15
	46257	23-3/8			20373	19		46102	HP-4		+15
	46258	24-3/8			20890	20		46102	HP-4		+15
	85592	25-3/8			41310	21		46102	HP-4		+15
	47067	25-3/4			545022	22		46342	EP-4		+20
46252	26-3/8			2243	22		46102	HP-4		+15	
87208	26-3/8			545022	22		86784	FP-4		+15	
47077	25-3/4			545022	22		88991	LP-4		-20	
544553	26-3/8			545022	22		86760	HP-4		+15	
87320	26-3/8			545022	22		87322	HP-4		+15	
64131	26-3/8			545022	22		43005	HP-4		+15	
87079	26-3/8			2243	22		86760	HP-4		+15	
46252	26-3/8			2243	22		46102	HP-4		+15	
525661	27-3/4	46169	3/4	18282	24	539322	46342	EP-4	3/4-14	+20	
46259	28-3/8			18282	24		46102	HP-4		+15	
46256	30-3/8			20438	26		46102	HP-4		+15	
46597	32-3/8			19450	28		86784	FP-4		+15	
520724	32-3/8			19450	28		86760	HP-4		+15	
544596	33-3/4			19539	30		46342	EP-4		+20	
46601	34-3/8			19539	30		86784	FP-4		+15	
88992	33-3/4			19539	30		88991	LP-4		-20	
49279	34-3/8			19539	30		46102	HP-4		+15	
88993	34-3/8	46169	3/4	19539	30	539322	86760	HP-4	3/4-14	+15	

Prices will be quoted upon application

Orders should give PIECE NUMBER and NAME of part wanted

HOSE WITH THREADED NIPPLE AND HOSE COUPLING (continued)

3216-3

Diameter	Complete Pc. No.	Overall Length "B" inches	Fitting, Ref. 2		Hose, Ref. 3		Clamp Ref. 4	Fitting, Ref. 5		"C"	Offset ^o "M"	
			Pc. No.	Size inches	Pc. No.	Length "A" inches		Pc. No.	Type			
1-1/8	527553	35-3/8	46169	3/4	544966	31	539322	86760	HP-4	3/4-14	+15	
	529978	35-3/8			544966	31		46102	HP-4		+15	
	536059	40-3/8			4893	36		46102	HP-4		+15	
	46602	64-3/8			30469	60		86784	FP-4		+15	
	46260	64-3/8			30469	60		46102	HP-4		+15	
	46599	67-3/8	46169	3/4	21289	63	539322	86784	FP-4	3/4-14	+15	
	46598	72-3/8			8985	68		86784	FP-4		+15	
	46202	76-3/8			544982	72		46102	HP-4		+15	
	46261	82-3/8			47914	78		46102	HP-4		+15	
	46600	124-3/8			35353	120		86784	FP-4		+15	
	74788	148-3/8	46169	3/4	544971	144	539322	46102	HP-4	3/4-14	+15	
1-1/8	46581	18-3/4	46175	1	20098	14	539322	86784	FP-4	1	+15	
	46587	19-3/4			21332	15		86784	FP-4		+15	
	46582	20-3/4			23002	16		86784	FP-4		+15	
	46580	21-3/4			19416	17		86784	FP-4		+15	
	47076	21-3/8			19416	17		88991	LP-4		-20	
	47109	21-3/8			19275	18		46346	FL-4		—	
	47065	22-1/8			19275	18		46342	EP-4		+20	
	46591	22-3/4			19275	18		86784	FP-4		+15	
	82816	22-3/4			19275	18		46102	HP-4		+15	
	90773	22-3/4			19275	18		86760	HP-4		+15	
	46585	23-3/4			20375	19		86784	FP-4		+15	
	47108	23-3/8			20890	20		46346	FL-4		—	
	46594	24-3/4			20890	20		86784	FP-4		+15	
	84044	24-3/8			20890	20		88991	LP-4		-20	
	46586	25-3/4			41310	21		86784	FP-4		+15	
	47064	26-1/8	46175	1	545022	22	539322	46342	EP-4	1	+20	
	92364	26-3/4			545022	22		86784	FP-4		+15	
	46369	26-3/8			545022	22		88991	LP-4		-20	
	49011	26-3/4			545022	22		46102	HP-4		+15	
	87183	26-3/4			545022	22		86760	HP-4		+15	
	88994	28-3/4			18282	24		86784	FP-4		+15	
	525660	28-3/8			18282	24		88991	LP-4		-20	
	46592	34-3/4			19539	30		86784	FP-4		+15	
	544597	34-3/8			19539	30		88991	LP-4		-20	
	64387	36-3/8			55861	32		88991	LP-4		-20	
	49390	38-3/4			49388	34		86784	FP-4		+15	
	66192	40-3/4			4893	36		86784	FP-4		+15	
	536057	40-3/8			4893	36		88991	LP-4		-20	
	70583	44-3/8			19924	40		86784	FP-4		+15	
	46593	48-3/4			41034	44		86784	FP-4		+15	
	46588	52-3/4	46175	1	21456	48	539322	86784	FP-4	1	+15	
	1-1/8	46572	18-3/4	46164	1-1/4	20098	14	539322	86784	FP-4	1-1/4	+15
		46574	20-3/4			23002	16		86784	FP-4		+15
77689		21-3/4			19416	17		86784	FP-4		+15	
56786		22-3/4			19275	18		86784	FP-4		+15	
46577		23-3/4	46164	1-1/4	20373	19	539322	86784	FP-4	1-1/4	+15	

Prices will be quoted upon application

Orders should give PIECE NUMBER and NAME of part wanted

HOSE WITH THREADED NIPPLE AND HOSE COUPLING (continued)

* NOTE: Whitworth Thread

Diameter	Complete Pc. No.	Overall Length "B" inches	Fitting, Ref. 2		Hose, Ref. 3		Clamp Ref. 4	Fitting, Ref. 5		"C"	Offset ^o "M"
			Pc. No.	Size inches	Pc. No.	Length "A" inches		Pc. No.	Type		
1-1/8	46571	24-3/4	46164	1-1/4	20890	20	539322	86784	FP-4	1-1/4	+15
	46283	26-3/4			545022	22		86784	FP-4		+15
	58618	26-3/8			545022	22		88991	LP-4		-20
	87100	26-3/4			2243	22		86784	FP-4		+15
	46276	26-3/4	46164	1-1/4	545022	22	539322	46102	HP-4	1-1/4	+15
	524106	28-3/4			18282	24		86784	FP-4		+15
	51514	34-3/4			19539	30		86784	FP-4		+15
	46570	40-3/4	46164	1-1/4	4893	36	539322	86784	FP-4	1-1/4	+15
	46576	52-3/4			12456	48		86784	FP-4		+15
	46575	64-3/4	46164	1-1/4	30469	60	539322	86784	FP-4	1-1/4	+15
1-3/8	53699	9-3/4	46223	1-1/4	544973	5	539321	46100	FP-5	1-1/4	+15
	46301	16-3/4			19445	12					
	46296	18-3/4			22716	14					
	46299	19-3/4	46223	1-1/4	30083	15	539321	46100	FP-5		
	46304	20-3/4			38978	16		46100	FP-5		
	526208	21-3/4			28069	17		86739	FP-5		
	46295	22-3/4			21233	18		46100	FP-5		
	90774	22-3/4	46223	1-1/4	21233	18		86739	FP-5		
	46290	23-3/4			19311	19		46100	FP-5		
	89315	23-3/4			19311	19		86739	FP-5		
	46289	24-3/4			20303	20		46100	FP-5		
	89002	24-3/4	46223	1-1/4	20303	20	539321	86739	FP-5		
	46305	25-3/4			44872	21		46100	FP-5		
	89116	25-3/4			44872	21		86739	FP-5		
	46242	26-3/4			2463	22		46100	FP-5		
	544552	26-3/4	46223	1-1/4	545023	22		86739	FP-5		
	82999	26-3/4	* 82998	1-1/2	545023	22	539321	46100	FP-5	1-1/4	+15
	87101	26-3/4	46223	1-1/4	2463	22		86739	FP-5		
	552775	26-3/4			552774	22		86739	FP-5		
	545449	26-3/4			2463	22		545525	FP-5		
	46297	28-3/4			20638	24		46100	FP-5		
	46302	29-3/4	46223	1-1/4	41313	25	539321				
	46288	30-3/4			19608	26					
	64237	31-3/4			544976	27					
	46298	32-3/4			29649	28		46100	FP-5		
	89099	32-3/4	46223	1-1/4	29649	28		86739	FP-5		
	63877	34-3/4			21705	30		46100	FP-5		
	551219	37-3/4			551220	33		551218	FP-5		
	549928	38-3/4			41312	34		86739	FP-5		
	46300	38-3/4			41312	34		46100	FP-5		
	85815	40-3/4			29089	36		46100	FP-5		
	505182	40-3/4	46223	1-1/4	29089	36	539321	86739	FP-5		
	536058	44-3/4			544980	40		46100	FP-5		
	46306	64-3/4			33530	60		46100	FP-5		
	46303	76-3/4			41314	72		46100	FP-5		
	46307	82-3/4	46223	1-1/4	47913	78		46100	FP-5	1-1/4	
46308	100-3/4	46272	1	16308	96		46100	FP-5	1	+15	
547211	172-3/4	46223	1-1/4	547804	168		86739	FP-5	1-1/4		
79571	208-3/4			544987	204		46100	FP-5			
83562	364-3/4	46223	1-1/4	544990	360	539321	46100	FP-5	1-1/4	+15	

Prices will be quoted upon application

Orders should give PIECE NUMBER and NAME of part wanted

HOSE WITH THREADED NIPPLE AND THREADED UNION NIPPLE

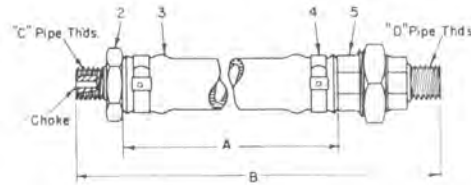

* NOTE: Nipple with 3/16 Choke.

Diameter	Complete Pc. No.	Overall Length "B" inches	Fitting, Ref. 2		Hose, Ref. 3		Clamp Ref. 4	Fitting, Ref. 5		"C"	"D"					
			Pc. No.	Size inches	Pc. No.	Length "A" inches		Pc. No.	Size inches							
3/8	553642	25-1/2	53975	3/8	31067	22	542883	553641	3/8	3/8-18	3/8-18					
1/2	550120	51-7/8	6390	1/2	544907	48	547040	550119	1/2	1/2-14	1/2-14					
	551163	63-7/8	6390	1/2	48930	60	547040	550119	1/2	1/2-14	1/2-14					
5/8	546393	58-7/8	532838	1/2	546392	55	541051	546405	1/2	1/2-14	1/2-14					
3/4	550199	29-7/8	8417	1/2	21883	26	541051	545657	1/2	1/2-14	1/2-14					
	547692	31-7/8			22155	28										
	547693	33-7/8			20092	30										
	547694	34-7/8			544934	31						541051	545657	1/2	1/2-14	1/2-14
	545335	35-7/8			544935	32										
	547695	48-7/8	8417	21489	45											
	547696	54-7/8	543138*	544940	51											
	547697	56-7/8	8417	544942	53											
	545611	57-7/8	8417	544943	54											
	547482	60-7/8	8417	547641	57	541051	545657	1/2	1/2-14	1/2-14						
3/4	545601	13-7/8	7968	3/4	20101	10	541051	545657	1/2	3/4-14	1/2-14					
3/4	548535	33-3/8	7968	3/4	547665	29	541051	534318	3/4	3/4-14	3/4-14					
	548637	35-3/8			544934	31										
	553830	36-3/8	8417	1/2	544935	32	541051	534318	3/4	1/2-14	3/4-14					
	550121	52-3/8	7968	3/4	544939	48	541051	534318	3/4	3/4-14	3/4-14					
	533922	56-3/8			544941	52										
	545617	64-3/8			35365	60										
	544850	84-3/8			544849	80						541051	534318	3/4	3/4-14	3/4-14
7/8	546388	29-5/8	532839	3/4	546387	25	541052	537001	3/4	3/4-14	3/4-14					
	546836	31-5/8	532839	3/4	546833	27	541052	537001	3/4	3/4-14	3/4-14					
	546390	39-5/8	532839	3/4	546389	35	541052	537001	3/4	3/4-14	3/4-14					
1-1/8	547720	17-5/8	46169	3/4	56441	13	539322	544811	3/4	3/4-14	3/4-14					
	547041	27-5/8			544963	23										
	547722	28-5/8			18282	24										
	547724	29-5/8			544964	25										
	547637	30-5/8			20438	26										
	547636	32-5/8			19450	28										
	547726	34-5/8			19539	30										
	545337	35-5/8			65594	29						539322	544811	3/4	3/4-14	3/4-14
	547638	40-5/8			4893	36										
	547728	47-5/8			547716	43										
	547729	50-5/8			547717	46										
	547730	51-5/8			547718	47										
	545612	58-5/8			31730	54										
	547731	59-5/8	46169	3/4	547719	55	539322	544811	3/4	3/4-14	3/4-14					
1-1/8	545336	26-7/8	46169	3/4	545022	22	539322	534317	1	3/4-14	1-11-1/2					

Prices will be quoted upon application

Orders should give PIECE NUMBER and NAME of part wanted

HOSE WITH THREADED NIPPLE AND THREADED UNION NIPPLE (continued)

Diameter	Complete Pc. No.	Overall Length "B" inches	Fitting, Ref. 2		Hose, Ref. 3			Fitting, Ref. 5		"C"	"D"
			Pc. No.	Size inches	Pc. No.	Length "A" inches	Clamp Ref. 4	Pc. No.	Size inches		
1-1/8	545602	14-1/8	46175	1	545102	9	539322	534317	1	1-11-1/2	1-11-1/2
	547721	18-1/8			56441	13					
	547723	29-1/8			18282	24					
	547725	32-1/8			544965	27					
	546394	33-1/8			19450	28					
	547640	34-1/8			46175	1					
	553829	36-1/8			544966	31					
	547727	47-1/8			30355	42					
	547483	59-1/8			31730	54					
533920	62-1/8	46175	1	45615	57	539322	534317	1	1-11-1/2	1-11-1/2	
1-1/8	545338	27-1/8	46164	1-1/4	545022	22	539322	534317	1	1-1/4-11-1/2	1-11-1/2
1-3/8	547751	24-5/8	46223	1-1/4	19311	19	539321	537003	1-1/4	1-1/4-11-1/4	1-1/4-11-1/2
	547089	29-5/8			20638	24					
	547631	30-5/8			41313	25					
	547752	32-5/8	46223	1-1/4	544976	27	539321	537003	1-1/4	1-1/4-11-1/4	1-1/4-11-1/2
	545341	33-5/8			29649	28					
	547635	34-5/8			544977	29					
	547753	51-5/8			41315	46					
	547484	59-5/8	46223	1-1/4	31732	54	539321	537003	1-1/4	1-1/4-11-1/2	1-1/4-11-1/2

HOSE WITH TAPPED NIPPLE AND THREADED UNION NIPPLE

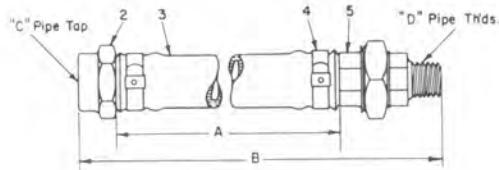

Diameter	Complete Pc. No.	Overall Length "B" inches	Fitting, Ref. 2		Hose, Ref. 3			Fitting, Ref. 5		"C"	"D"
			Pc. No.	Size inches	Pc. No.	Length "A" inches	Clamp Ref. 4	Pc. No.	Size inches		
1-1/8	545608	26-1/8	46178	3/4	545022	22	539322	544813	1/2	3/4-14	1/2-14
1-1/8	545607	26-1/4	46178	3/4	545022	22	539322	544811	3/4	3/4-14	3/4-14

Prices will be quoted upon application

Orders should give PIECE NUMBER and NAME of part wanted

HOSE WITH TAPPED NIPPLE AND TAPPED UNION NIPPLE

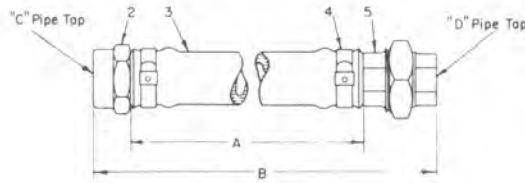

Diameter	Complete Pc. No.	Overall Length "B" inches	Fitting, Ref. 2		Hose, Ref. 3		Clamp Ref. 4	Fitting, Ref. 5		"C"	"D"
			Pc. No.	Size inches	Pc. No.	Length "A" inches		Pc. No.	Size inches		
1/2	545167	39	44277	1/2	19576	36	547040	544806	1/2	1/2-14	1/2-14
5/8	541691	29	532836	1/2	544227	26	541051	533446	1/2	1/2-14	1/2-14
3/4	545171	15	48378	1/2	19180	12	541051	544808	1/2	1/2-14	1/2-14
	545177	25			8643	22					
	545180	28	48378	1/2	35422	25	541051	544808	1/2	1/2-14	1/2-14
	545186	39	48378	1/2	19316	36	541051	544808	1/2	1/2-14	1/2-14
	547453	45			9890	42					
	545189	65	48378	1/2	544944	62	541051	544808	1/2	1/2-14	1/2-14
	554084	81			19037	78					
	555832	135	48378	1/2	555837	132	541051	544808	1/2	1/2-14	1/2-14
3/4	545172	15-1/2	15229	1	19180	12	541051	541765	3/4	1-11-1/2	3/4-14
	545179	25-1/2	15229	1	8643	22	541051	541765	3/4	1-11-1/2	3/4-14
	545175	26-1/2	15229	1	8643	22	541051	544807	1	1-11-1/2	1-11-1/2
	545168	9-1/4	14773	3/4	544933	6	541051	541765	3/4	3/4-14	3/4-14
	545169	11-1/4			14487	8					
	545170	15-1/4			19180	12					
	545173	23-1/4			19179	20					
	545174	25-1/4			8643	22					
	545181	29-1/4			21883	26					
	545183	31-1/4			22155	28					
	545184	33-1/4	14773	3/4	20092	30	541051	541765	3/4	3/4-14	3/4-14
	545185	39-1/4			19316	36					
	545187	47-1/4			53497	44					
	545188	51-1/4			544939	48					
	545190	69-1/4			544945	66					
	545191	243-1/4			544950	240					
	545192	363-1/4	14773	3/4	545106	360	541051	541765	3/4	3/4-14	3/4-14
	545178	26-1/4	14773	3/4	8643	22	541051	544807	1	3/4-14	1-11-1/2
	545182	30-1/4	14773	3/4	21883	26	541051	544807	1	3/4-14	1-11-1/2
	7/8	541686	13-1/4	532837	3/4	544954	10	541052	533508	3/4	3/4-14
541910		25-1/4			544956	22					
541690		29-1/4			544228	26					
541689		33-1/4			544959	30					
541685		37-1/4	532837	3/4	544960	34	541052	533508	3/4	3/4-14	3/4-14
545207		27-1/4	511388	1/2	18282	24	539322	544812	1/2	1/2-14	1/2-14
545204	25-3/8	46178	3/4	545022	22	539322	544812	1/2	3/4-14	1/2-14	

Prices will be quoted upon application

Orders should give PIECE NUMBER and NAME of part wanted

HOSE WITH TAPPED NIPPLE AND TAPPED UNION NIPPLE (continued)

Diameter	Complete Pc. No.	Overall Length "B" inches	Fitting, Ref. 2		Hose, Ref. 3		Clamp Ref. 4	Fitting, Ref. 5		"C"	"D"
			Pc. No.	Size inches	Pc. No.	Length "A" inches		Pc. No.	Size inches		
1-1/8	545194	11-3/8	46178	3/4	5089	8	539322	544810	3/4	3/4-14	3/4-14
	545212	39-3/8			4893	36		544810	3/4	3/4-14	3/4-14
	545200	25-3/8			545022	22		544810	3/4	3/4-14	3/4-14
	545203	25-5/8			545022	22		544814	1	3/4-14	1-11-1/2
	545208	29-5/8	46178	3/4	20438	26	539322	544814	1	3/4-14	1-11-1/2
	545197	19-3/8	46180	1	23002	16	539322	544810	3/4	1-11-1/2	3/4-14
	545193	11-5/8	46180	1	5089	8	539322	544814	1	1-11-1/2	1-11-1/2
	545195	15-5/8			19144	12					
	545196	19-5/8			23002	16					
	545198	23-5/8			20890	20					
	545199	25-5/8			545022	22					
	545206	27-5/8	46180	1	18282	24	539322	544814	1	1-11-1/2	1-11-1/2
	545209	31-5/8	46180	1	19450	28	539322	544814	1	1-11-1/2	1-11-1/2
	545210	33-5/8			19539	30					
	545211	39-5/8			4893	36					
	545213	45-5/8			30355	42					
	545214	60-5/8			45615	57					
	545215	69-5/8	46180	1	43883	66	529322	544814	1	1-11-1/2	1-11-1/2
1-3/8	545219	26-1/8	46273	1-1/4	545023	22	539321	547960	1-1/4	1-1/4-11-1/2	1-1/4-11-1/2
	545222	34-1/8	46273	1-1/4	21705	30	539321	547960	1-1/4	1-1/4-11-1/2	1-1/4-11-1/2
	545223	40-1/8	46273	1-1/4	29089	36	539321	547960	1-1/4	1-1/4-11-1/2	1-1/4-11-1/2

HOSE WITH TAPPED NIPPLE AND HOSE COUPLING

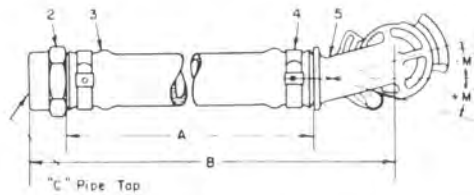

Diameter	Complete Pc. No.	Overall Length "B" inches	Fitting, Ref. 2		Hose, Ref. 3		Clamp Ref. 4	Fitting, Ref. 5		"C"	Offset "M"
			Pc. No.	Size inches	Pc. No.	Length "A" inches		Pc. No.	Size Type		
3/4	32311	25-3/8	14773	3/4	8643	22	541051	518015	LP-3	3/4-14	-20
	68783	57-3/8	14773	3/4	544943	54	541051	518015	LP-3	3/4-14	-20
	19038	81-3/8	14773	3/4	19037	78	541051	518015	LP-3	3/4-14	-20
3/4	19313	25-3/4	15229	1	8643	22	541051	518015	LP-3	1-11-1/2	-20
1-1/8	66539	22	46178	3/4	19275	18	539322	86784	FP-4	3/4-14	+15

Prices will be quoted upon application

Orders should give PIECE NUMBER and NAME of part wanted

HOSE WITH "MK" COUPLING AND TAPPED NIPPLE

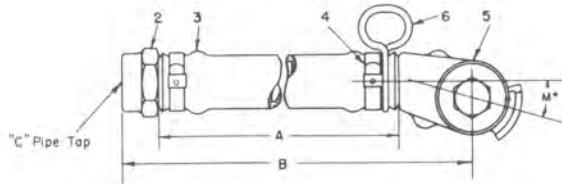

Diameter	Complete Pc. No.	Overall Length "B" inches	Fitting, Ref. 2		Hose, Ref. 3		Clamp Ref. 4	Fitting, Ref. 5		"C"
			Pc. No.	Size inches	Pc. No.	Length "A" inches		Pc. No.	Size Type	
1-1/8	527490	28-3/8	46169	3/4	18282	24	539322	46344	MK-4	3/4-14
1-1/8	47074	22-3/4	46175	1	19275	18	539322	46344	MK-4	1-11-1/2
	47073	24-3/4	46175	1	20890	20	539322	46344	MK-4	1-11-1/2
	47072	26-3/4	46175	1	545022	22	539322	46344	MK-4	1-11-1/2

HOSE WITH COUPLING AND TAPPED UNION NIPPLE

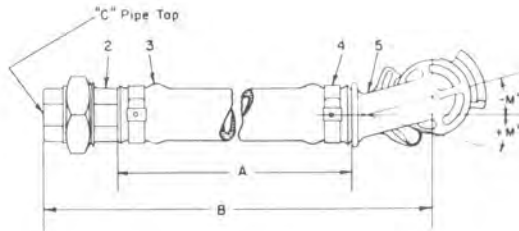

Diameter	Complete Pc. No.	Overall Length "B" inches	Fitting, Ref. 2		Hose, Ref. 3		Clamp Ref. 4	Fitting, Ref. 5		"C"	Offset ^o "M"
			Pc. No.	Size inches	Pc. No.	Length "A" inches		Pc. No.	Size Type		
1/2	71037		544804	3/8	544914	300	547040	22577	AY-2	3/8-18	
1/2	67873		544806	1/2	45157	22	547040	22577	AY-2	1/2-14	
	71962		544806	1/2	544902	25	547040	22577	AY-2	1/2-14	
	73846		544806	1/2	544924	1440	547040	22577	AY-2	1/2-14	
3/4	545162	26-5/8	541765	3/4	8643	22	541051	518015	LP-3	3/4-14	-20
	545164	58-5/8	541765	3/4	544943	54	541051	518015	LP-3	3/4-14	-20
	545165	82-5/8	541765	3/4	19037	78	541051	518015	LP-3	3/4-14	-20
3/4	545163	27-1/2	544807	1	8643	22	541051	518015	LP-3	1-11-1/2	-20
1-1/8	547392	27-1/8	544810	3/4	554022	22	539322	86784	FP-4	3/4-14	+15
	547393	41-1/8	544810	3/4	4893	36	539322	86784	FP-4	3/4-14	+15

Prices will be quoted upon application

Orders should give PIECE NUMBER and NAME of part wanted

HOSE WITH THREADED UNION NIPPLE, THREADED NIPPLE AND COUPLING

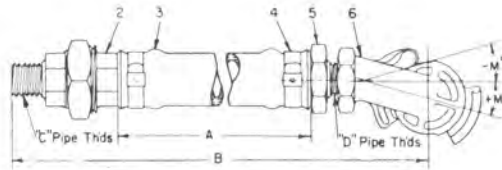

Diameter	Complete Pc. No.	Overall Length "B" inches	Hose Comb. Pc. No.	Hose, Ref. 3		Clamp Ref. 4	Fitting, Ref. 6		"C"	"D"	Offset "M"
				Pc. No.	Length "A" inches		Pc. No.	Type			
3/4	548638	37-5/8	548637	544934	31	541051	505490	ES-3	3/4-14	3/4-14	+20

HOSE WITH TAPPED ANGLE NIPPLE AND THREADED NIPPLE

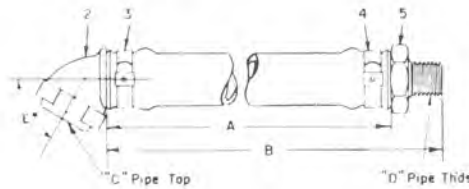

Diameter	Complete Pc. No.	Overall Length "B" inches	Fitting, Ref. 2		Hose, Ref. 3		Clamp Ref. 4	Fitting, Ref. 5		"C"	"D"	"E"
			Pc. No.	Size inches	Pc. No.	Length "A" inches		Pc. No.	Size inches			
1-1/8	72006	12-7/8	46175	1	545103	11	539322	46162	1	1-11-1/2	1-11-1/2	60

HOSE WITH TAPPED UNION NIPPLE AND STRAIGHT FLANGE FITTING

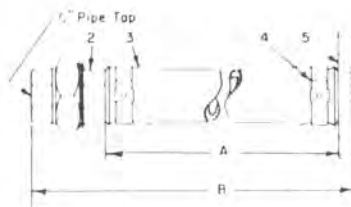

Diameter	Complete Pc. No.	Overall Length "B" inches	Fitting, Ref. 2		Hose, Ref. 3		Clamp Ref. 4	Fitting, Ref. 5		"C"
			Pc. No.	Size inches	Pc. No.	Length "A" inches		Pc. No.	Size inches	
1-1/8	547450	27-1/8	544810	3/4	545022	22	539322	506472	3/4	3/4-14

Prices will be quoted upon application

Orders should give PIECE NUMBER and NAME of part wanted

HOSE WITH COUPLING AND TAPPED "EL" FLANGE NIPPLE

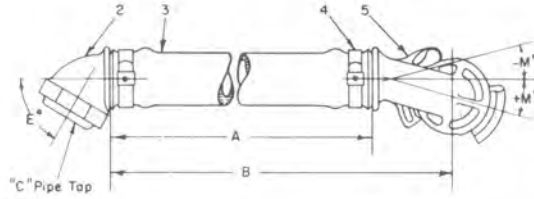

Diameter	Complete Pc. No.	Overall Length "B" inches	Fitting, Ref. 2		Hose, Ref. 3		Clamp Ref. 4	Fitting, Ref. 5		"C"	Offset °	
			Pc. No.	Size inches	Pc. No.	Length "A" inches		Pc. No.	Type		"E"	"M"
3/4	28121	24-1/2	13470	3/4	8643	22	541051	13447	NK-3	3/4-14	45 ⁰	-20
1-1/8	46603	24-7/8	46170	3/4	545022	22	539322	86784	FP-4	3/4-14	45 ⁰	+15
	543482	24-7/8	46170	3/4	545022	22	539322	86760	HP-4	3/4-14	45 ⁰	+15

HOSE WITH TWO STRAIGHT FLANGE FITTINGS

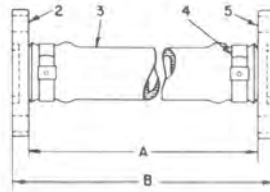

Diameter	Complete Pc. No.	Overall Length "B" inches	Fitting, Ref. 2		Hose, Ref. 3		Clamp Ref. 4	Fitting, Ref. 5	
			Pc. No.	Size inches	Pc. No.	Length "A" inches		Pc. No.	Size inches
1/2	503146	27-1/2	504091	3/8	41303	26	547040	504091	3/8
	537329	30-1/2			47844	29			
	537330	36-1/2	504091	3/8	544905	35	547040	504091	3/8
	542128	43-1/2			19577	42			
	548906	47-1/2	504091	3/8	548905	46	547040	504091	3/8
3/8	543164	28-3/4	530856	3/8	547682	27	542883	530856	3/8
	547681	28-3/4	530856	3/8	547682	27	542883	530856	3/8
	541693	32-5/8	541441	3/8	544896	30	542883	541441	3/8

Prices will be quoted upon application

Orders should give PIECE NUMBER and NAME of part wanted

HOSE WITH THREADED NIPPLES AND SPECIAL UNION FITTING

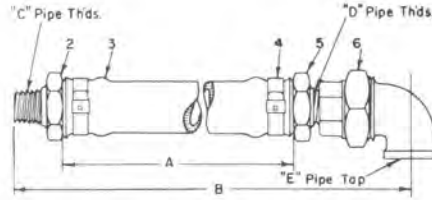

Diameter	Complete Pc. No.	Overall Length "B" inches	Complete Less El Union	Hose, Ref. 3		Clamp Ref. 4	Fitting, Ref. 6		"C"	"D"	"E"
				Pc. No.	Length "A" inches		Pc. No.	Size inches			
3/4	548542	34-1/2	543409	20092	30	541051	532831	3/4	3/4-18	3/4-18	3/4-18
1-3/8	548543	35-5/8	524464	544977	29	539321	532833	1-1/4	1-1/4-11-1/2	1-1/4-11-1/2	1-1/4-11-1/2

HOSE WITH TAPPED ANGLE AND UNION NIPPLE

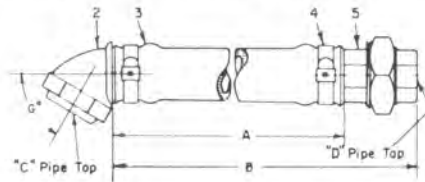

Diameter	Complete Pc. No.	Fitting, Ref. 2		Hose, Ref. 3		Clamp Ref. 4	Fitting, Ref. 5		Offset ° "G"
		Pc. No.	Size "C"	Pc. No.	Length "A" inches		Pc. No.	Size "D"	
1-1/8	545216	46162	1-11-1/2	545022	22	539322	544814	1-11-1/2	60°
	545218	46162	1-11-1/2	4893	36	539322	544814	1-11-1/2	
1-3/8	545224	81718	1-1/4-11-1/2	525023	22	539321	547960	1-1/4-11-1/2	60°

HOSE WITH SPECIAL ANGLE FLANGE FITTINGS

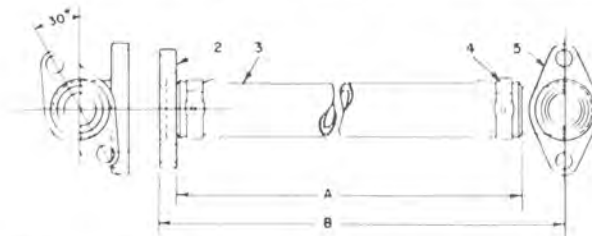

Diameter	Complete Pc. No.	Approx. Overall Length "B" inches	Fitting, Ref. 2		Hose, Ref. 3		Clamp Ref. 4	Fitting, Ref. 5	
			Pc. No.	Flange Size	Pc. No.	Length "A" inches		Pc. No.	Flange Size
1-1/8	547626	60	547624	1	547627	58	539322	547625	1

Prices will be quoted upon application Orders should give PIECE NUMBER and NAME of part wanted

HOSE WITH WABCOTITE FITTINGS

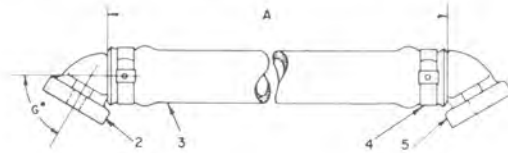

Diameter	Complete Pc. No.	Fitting, Ref. 2		Hose, Ref. 3			Fitting, Ref. 5		Offset ° "G"
		Pc. No.	Size inches	Pc. No.	Length "A" inches	Clamp Ref. 4	Pc. No.	Size Flange	
1/2	†542111	512301	1/2	19576	36	547040	512301	1/2	60°
1-3/8	542037	508960	1-1/4	29089	36	539321	508960	1-1/4	60°
	*507095	511563	1-1/4	29089	36	539321	511563	1-1/4	60°
	**508851	511565	1-1/4	29089	36	539321	511565	1-1/4	60°

HOSE WITH TAPPED NIPPLE AND WABCOTITE "EL" FITTINGS

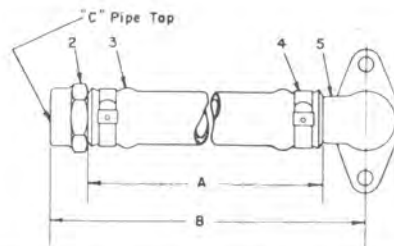

Diameter	Complete Pc. No.	Overall Length "B" inches	Fitting, Ref. 2		Hose, Ref. 3			Fitting, Ref. 5		"C"
			Pc. No.	Size inches	Pc. No.	Length "A" inches	Clamp Ref. 4	Pc. No.	Size inches	
1-3/8	546229	23-5/8	543679	1-1/4	44872	21	539321	533525	1-1/4	1-1/4-11-1/2
	541696	26-5/8	543679	1-1/4	20638	24	539321	533523	1-1/4	1-1/4-11-1/2

† NOTE - Pc. 512296 covers Pc. 542111 with WABCOTITE ® Fittings and support Plug

*NOTE - Includes 1-1/4 in WABCOTITE ® Fitting for 1-1/4 in. Pipe.

**NOTE - Includes 1-1/4 in WABCOTITE ® Fitting for 3/4 in Pipe.

Prices will be quoted upon application

Orders should give PIECE NUMBER and NAME of part wanted

HOSE WITH TWO THREADED NIPPLES AND COUPLINGS

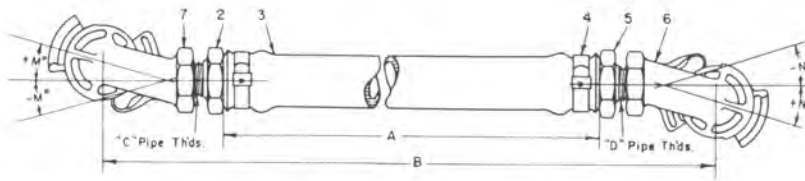

Diameter	Complete Pc. No.	Overall Length "B" inches	Hose Comb. Pc. No. **	Hose, Ref. 3		Clamp Ref. 4	Ref. 6 & 7 Fitting		"C"	"D"	Offset ° "M - N"
				Pc. No.	Length "A" inches		Pc. No.	Type			
1-1/8	* 536352	248-5/8	—	545104	240	539322	536285	LS-3	3/4	3/4	-20

*Note: Pc. No. includes nipple with 3/32 in. choke

**Note: Hose Combinations include Ref. Nos. 2, 3, 4 and 5

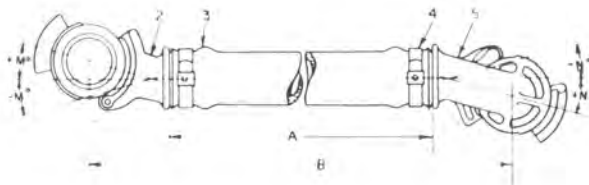

Diameter	Complete Pc. No.	Overall Length "B" inches	Fitting Ref. 2 & 5 Pc. No.	Hose, Ref. 3		Clamp Ref. 4	Fitting, Ref. 5		Offset °	
				Pc. No.	Length "A" inches		Pc. No.	Type	"M"	"N"
1/2	68428		35585	545101	120	547040	35585	AY-2	1/2	1/2
	73847		22577	544912	180		22577	AY-2		
	51100		22577	544914	300		22577	AY-2		
	67780		35585	544914	300		35585	AY-2		
	34612		22577	544920	600		22577	AY-2		
	35584		35585	544920	600	547040	35585	AY-2	1/2	1/2

Prices will be quoted upon application

Orders should give PIECE NUMBER and NAME of part wanted

HOSE WITH TWO COUPLINGS

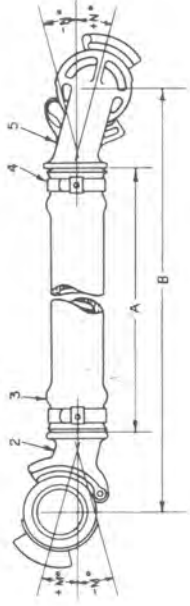

Diameter	Complete P.c. No.	Overall Length "B" inches	Fitting, Ref. 2		Hose, Ref. 3		Clamp Ref. 4	Fitting, Ref. 5		Offset °	
			P.c. No.	Type	P.c. No.	Length "A" inches		P.c. No.	Type	"M"	"N"
3/4	19174	17-1/8	11122	EP-3	19180	12	541051	10710	FP-3	+20	+15
	19178	25-1/8	11122	EP-3	19179	20		10710	FP-3	+20	+15
	19319	26-1/2	11122	EP-3	8643	22		11122	EP-3	+20	+15
	19320	26-1/2	518015	LP-3	8643	22		518015	LP-3	-20	-20
	20093	34-1/2	11122	EP-3	20092	30		11122	EP-3	+20	+20
	20096	34-1/2	518015	LP-3	20092	30	541051	518015	LP-3	-20	-20
	19315	40-1/2	11122	EP-3	19316	36		11122	EP-3	+20	+20
	19314	40-1/2	518015	LP-3	19316	36		518015	LP-3	-20	-20
	41032	65-1/2	518015	LP-3	41031	61		518015	LP-3	-20	-20
	40342	70-1/2	518015	LP-3	544945	66		518015	LP-3	-20	-20
1-1/8	34000	124-1/2	11122	EP-3	35424	120		11122	EP-3	+20	+20
	33986	305-3/4	10710	FP-3	544951	300	541051	10710	FP-3	+15	+15
	46762	15-3/4	86784	FP-4	19377	10	539322	86784	FP-4	+15	+15
	46766	17-3/4	86784	FP-4	19144	12					
	46765	19-3/4	86784	FP-4	20098	14		86784	FP-4		
	46768	23-3/4	86784	FP-4	19275	18		86784	FP-4		
	46764	27-3/4	86784	FP-4	545022	22		86784	FP-4		
	70732	27-3/4	46102	HP-4	545022	22	539322	46102	HP-4	+15	+15
	46767	35-3/4	86784	FP-4	19539	30		86784	FP-4		
	46761	41-3/4	86784	FP-4	4893	36		86784	FP-4		
1-3/8	46763	65-3/4	86784	FP-4	30469	60		86784	FP-4	+15	+15
	51231	64-1/2	46342	EP-4	30469	60	539322	46342	EP-4	+20	+20
	46757	11-3/4	46100	FP-5	44545	6	539321	46100	FP-5	+15	+15
	66666	12-3/4			544974	7					
	46749	17-3/4			19445	12					
	47468	23-3/4			21233	18		46100			
	46748	27-3/4			545023	22					
	46752	29-3/4			20638	24					
	46756	31-3/4			19608	26					
	46751	34-3/4	46100		544977	29		46100			
1-1/2	541920	37-3/4	86739		544978	32		86739			+15
	549268	37-1/4	86739	FP-5	544978	32	539321	96943	FP-5	+15	-35
	46753	65-3/4	46100		33530	60		46100			+15
	50456	125-3/4			58737	120					
	71465	161-3/4			544985	156					
	71952	185-3/4			544986	180		46100			
	46754	245-3/4			544988	240					
	57751	305-3/4			544989	300					
	46755	365-3/4			544990	360					
	68248	485-3/4			544991	480					
1-3/4	46750	545-3/4			544992	540					
	550388	605-3/4	46100	FP-5	545412	600	539321	46100	FP-5	+15	+15

Prices will be quoted upon application. Orders should give PIECE NUMBER and NAME of part wanted.

HOSE WITH THREADED NIPPLES AND COUPLING

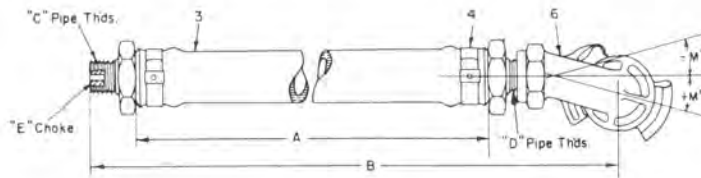

Diameter	Complete Pc. No.	Approx. Overall Length "B" inches	Hose Comb. Pc. No.	Hose, Ref. 3		Clamp Ref. 4	Fitting, Ref. 6		"C"	"D"	"E"	Offset ° "M"
				Pc. No.	Length "A" inches		Pc. No.	Type				
1/2	512495	26-5/8	512494	45157	22	547040	505490	ES-2	1/2	1/2	3/16	+15
	515668	26-3/4	512494	45157	22		514798	ES-2			3/16	—
	532981	28-5/8	542109	21507	24		505490	ES-2				+15
	526160	29-1/2	542109	21507	24		506388	HS-2				+15
	527682	33-1/2	542110	544903	28		506388	HS-2				+15
	536273	100-3/4	536282	58616	96		514798	ES-2				—
	536252	101-1/2	536282	58616	96	547040	506388	HS-2	1/2	1/2		+15
5/8	541606	24-1/2	541610	544928	19	541051	506388	HS-2	1/2	1/2		+15
	540568	27-1/2	540585	544929	22	541051	506388	HS-2	1/2	1/2		+15
	548317	28-5/8	547091	544795	24	541051	505490	ES-2	1/2	1/2		+15
	554371	30-5/8	554370	554227	26	541051	505490	ES-2	1/2	1/2		+15
3/4	547683	26-3/4	545451	8643	22	541051	505490	ES-2	1/2	1/2	3/16	+15
	547685	26-3/4	8641	8643	22		99713	LS-2	1/2	1/2		-20
	547684	26-3/4	545451	8643	22		514798	ES-2	1/2	1/2	3/16	—
	548537	27-5/8	21549	8643	22		504511	HS-3	3/4	3/4		+15
	545413	27	8641	8643	22		538551	EYS-2	1/2	1/2		—
	545414	27	545451	8643	22		538551	EYS-2	1/2	1/2	3/16	—
	548149	26-5/8	21549	8643	22		49163	ES-3	3/4	3/4		+15
	548538	28-5/8	548532	33289	24	541051	49163	ES-3	3/4	3/4		+15
	543011	29-5/8	543004	33289	24		504511	HS-3	1/2	3/4		+15
	547686	28-3/4	547672	33289	24		505490	ES-2	1/2	1/2	3/16	+15
	547687	29-3/4	547673	33289	24		504511	HS-3	1/2	3/4	3/16	+15
	547689	29-3/4	547674	35422	25		99713	LS-2	1/2	1/2	3/16	-20
	543007	30-5/8	543001	35422	25		506388	HS-2	1/2	1/2		+15
	548539	29-3/4	548533	35422	25		504511	HS-3	3/4	3/4		+15
	543008	30-3/4	543002	21883	26		505490	ES-2	1/2	1/2	3/16	+15
	547688	30-3/4	543002	21883	26		514798	ES-2	1/2	1/2	3/16	—
	547690	30-3/4	547680	21883	26	541051	99713	LS-2	1/2	1/2		-20
	549896	30-3/4	547680	21883	26		505490	ES-2	1/2	1/2		+15
	547663	34-5/8	547662	547665	29		506388	HS-2	1/2	1/2		+15
	547691	34-5/8	547676	20092	30		505490	ES-2	1/2	1/2	3/16	+15
	543012	35-5/8	543005	20092	30		504511	HS-3	1/2	3/4	3/16	+15
	543006	35-5/8	543000	20092	30		506388	HS-2	1/2	1/2		+15
	543408	34-5/8	543409	20092	30		49163	ES-3	3/4	3/4		+20
548540	35-5/8	543409	20092	30		504511	HS-3	3/4	3/4		+15	
548638	37-5/8	548637	544934	31	541051	49163	ES-3	3/4	3/4		+20	
548541	38-5/8	548534	544936	33		504511	HS-3	3/4	3/4		+15	
542859	39-5/8	542927	49389	34	541051	506388	HS-2	1/2	1/2		+15	

Prices will be quoted upon application

Orders should give PIECE NUMBER and NAME of part wanted

HOSE WITH THREADED NIPPLES AND COUPLING

† NOTE - Coupling has eye on shank for Dummy Coupling Chain.

Diameter	Complete Pc. No.	Approx. Overall Length "B" inches	Hose Comb. Pc. No.	Hose, Ref. 3		Clamp Ref. 4	Fitting, Ref. 6		"C"	"D"	"E"	Offset ° "M"
				Pc. No.	Length "A" inches		Pc. No.	Type				
3/4	543009	38-3/4	543003	49389	34	541051	514798	ES-2	1/2	1/2	3/16	—
	543010	38-3/4	543003	49389	34		505490	ES-2	1/2	1/2	3/16	+15
	549895	39	543003	49389	34		538551	EYS-2	1/2	1/2	3/16	—
	† 92832	53-5/8	546425	544939	48		87737	FS-3	3/4	3/4		—
	† 550362	54-1/8	550361	544939	48		87737	FS-3	3/4	1		—
	549773	61-5/8	549772	37696	56		506388	HS-2	1/2	1/2		+15
	† 550596	72-1/8	550594	544945	66		87737	FS-3	1	3/4		—
	520489	125-5/8	520561	35424	120		46983	HS-3	3/4	3/4		—
	† 550597	150-1/8	550595	51276	144	541051	87737	FS-3	1	3/4		—
1-1/8	542988	26-1/4	542982	41310	21	539322	49163	ES-3	3/4	3/4		+20
	542987	27-1/4	542982	41310	21		504511	HS-3	3/4			+15
	542989	28-1/4	542983	544963	23		49163	ES-3				+20
	† 547740	29-1/8	542983	544963	23		87817	FS-3				+15
	547741	28-3/8	542983	544963	23		536285	LS-3				-20
	542985	31-1/4	542980	544964	25		504511	HS-3				+15
	547333	31-1/4	547338	20438	26	539322	49163	ES-3	3/4	3/4		+20
	547742	32-1/4	547338	20438	26		504511	HS-3				+15
	547743	34-1/4	547733	65594	29		49163	ES-3				+20
	542986	39-1/4	542981	544967	33		504511	HS-3				+15
1-1/8	542978	26	542976	20890	20	539322	505508	LS-4	1	1		-15
	547661	29	547618	544963	23		505508	LS-4				-15
	542979	30	46681	18282	24		505508	LS-4				-15
	† 547744	30-3/4	46681	18282	24		88983	FS-4				—
	549482	31-1/8	46681	18282	24	539322	73301	HS-4	1	1		—
	† 548536	35-3/4	542975	65594	29		88983	FS-4				—
	546173	35	542975	65594	29	539322	545506	LS-4	1	1		-15
	542977	35	542975	65594	29		545506	LS-4				-15
	542860	40	542926	49388	34		505508	LS-4				-15
	549775	62	549774	549778	56	539322	505508	LS-4	1	1		-15
1-3/8	547763	25	547759	21233	18	539321	504513	FS-5	1-1/4	1-1/4		+15
	† 542994	27	47088	20303	20		87852	FS-5				+15
	547970	27	47088	20303	20		504513	FS-5				+15
	552087	28-3/4	47085	545023	22		552009	HS-5				+20
	543158	29-1/4	545512	545023	22		73303	HS-5				—
	† 542992	31	47086	20638	24		87852	FS-5				+15
	547791	31	47086	20638	24	539321	504513	FS-5	1-1/4	1-1/4		+15
	547764	34	547761	544976	27		504513	FS-5				+15
	† 524465	36	524464	544977	29		87852	FS-5				+15
	547792	36	524464	544977	29		504513	FS-5				+15
	† 542993	39	542990	544978	32		87852	FS-5				+15
	547793	39	542990	544978	32		504513	FS-5				+15
	† 529864	67	529865	33530	60		87852	FS-5				+15
	† 528364	70	528365	544984	63		87852	FS-5				+15
	† 518908	79	518907	41314	72	539321	87852	FS-5	1-1/4	1-1/4		+15

Prices will be quoted upon application

Orders should give PIECE NUMBER and NAME of part wanted

STANDARD COUPLINGS

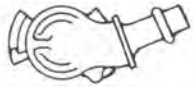
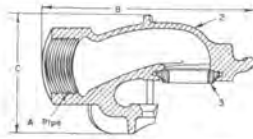

EP, FP, HP, LP



ES, HS



LS



FS, FV

Pc. No. Complete Ref. 2 *	Pc. No. Ref. 3	Description	A Tap or Thread.	B inches	C inches	Approx. Net Weight Lbs. Ea.
505490	538976	ES-2 Hose Coupling, with Shank at 15° Angle, Complete	1/2	4-7/8	2-1/4	1-5/8
514798	538976	ES-2 Hose Coupling with Straight Shank, Complete	1/2	4-3/4	2-1/4	1-3/4
548842	41817	ES-2 Hose Coupling with Shank at 15° Angle, Complete	1/2	4-7/8	2-1/4	1-3/4
506388	3279	HS-2 Hose Coupling, with Shank at 15° Angle, Complete	1/2	4-5/8	2-1/4	2-1/4
99713	3279	LS-2 Hose Coupling with Shank at 20° Angle, Complete	1/2	4-7/8	2-5/16	1-1/2
49163	538976	ES-3 Hose Coupling with Shank at 20° Angle, Complete	3/4	4-7/8	2-1/4	1-1/2
87737	3279	FS-3 Hose Coupling with Straight Shank, Complete	3/4	5-3/4	3-1/8	2-1/4
87817	3279	FS-3 Hose Coupling with Shank at an Angle, Complete	3/4	5-7/8	3-1/8	2-1/4
46983	3279	HS-3 Hose Coupling with Straight Shank, Complete	3/4	4-7/8	2-1/4	2-3/8
504511	3279	HS-3 Hose Coupling with Shank at an Angle, Complete	3/4	4-3/4	2-1/4	2-1/4
536285	3279	LS-3 Hose Coupling with Shank at an Angle, Complete	3/4	4-7/8	2-5/16	2
514296	538976	ES-4 Hose Coupling with Shank at an Angle, complete	1	4-3/4	2-5/16	1-1/2
88983	3279	FS-4 Hose Coupling with Straight Shank, Complete	1	5-3/4	3-1/4	2-1/4
89020	3279	FS-4 Hose Coupling with Shank at an Angle, Complete	1	5-7/8	3-1/4	2-1/4
73301	3279	HS-4 Hose Coupling with Straight Shank, Complete	1	6-3/16	2-7/8	2-1/2
505508	3279	LS-4 Hose Coupling, Shank at an Angle	1	5	2-1/4	2
87852	3279	FS-5 Hose Coupling with Shank at an Angle, Complete	1-1/4	6-1/4	3-1/2	2-1/2
73303	3279	HS-5 Hose Coupling with Straight Shank, Complete	1-1/4	6-5/16	2-7/8	2-3/4
552009	3279	HS-5 Hose Coupling with Shank at 20° Angle, Complete	1-1/4	6-7/16	2-7/8	2-3/4
¢ 538551	538976	EYS-2 Hose Coupling, Complete	1/2	4-7/8	3-1/4	2
¢ 549921	41817	EYS-2 Hose Coupling, Complete	1/2	4-7/8	3-1/4	2
97306	3279	FR-2 Hose Coupling, (Single Car Test Device) Complete	1/2	4-5/8	2-7/16	1-3/4
46246	None	FV-4 Hose Coupling, Complete	1-1/4	5-3/4	3-1/4	2
¢ 87772	2200	ON-2 Automotive Hose Coupling, Complete	1/2	4-1/4	2-1/2	2-1/2
¢ 87762	2200	OJ-2 Automotive Hose Coupling, Complete	1/2	4-1/4	2-15/16	2-1/2
79942	3279	FR-2 Hose Coupling, Single Car Test Device, Complete	1/2	4-5/8	2-7/16	1-3/4
82750	2200	AN-2 Hose Coupling, Complete	1/2	4-1/4	1-7/8	2

NOTE The above Piece Numbers cover Electro-tite Hose Couplings, the face and gasket groove of which are treated for rust prevention.

¢ NOTE For Complete Cataloging, see page 37

Prices will be quoted upon application
Orders should give PIECE NUMBER and NAME of part wanted

STANDARD COUPLINGS

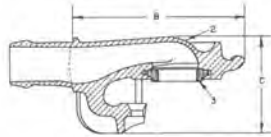

Pc. No. Complete Ref. 2 *	Pc. No. Ref. 3	Description	A Tap or Thread.	B inches	C inches	Approx. Net Weight Lbs. Ea.
11459	2200	AL-2 1/2 Hose Coupling, Complete		2-1/8	4-5/16	2
10901	2200	AM-2 Hose Coupling, Complete		2-1/4	4-5/16	2
22577	2200	AY-2 Hose Coupling, Complete		2-3/4	4-1/2	2
11122	538976	EP-3 Hose Coupling, Complete		2-5/16	4	1-1/2
10710	3279	FP-3 Hose Coupling, Complete		2-5/8	4-1/2	1-1/2
518015	3279	LP-3 Hose Coupling, Complete		2-7/8	4-3/8	1-1/4
46342	538976	EP-4 Hose Coupling, Complete		2-3/8	4-1/8	1-1/2
88991	3279	LP-4 Hose Coupling, Complete		2-7/8	4-3/8	1-1/2
87322	3279	HP-4 Hose Coupling, Complete		2-1/2	5-3/16	2
86760	3279	HP-4 Hose Coupling, Complete		2-1/2	5-3/16	2
86784	3279	FP-4 Hose Coupling, Complete		2-5/8	5-3/8	2-1/8
46100	3279	FP-5 Hose Coupling, Complete		3-5/16	5-3/8	2-1/4
86739	3279	FP-5 Hose Coupling, Complete		3-5/16	5-3/8	2-1/4
96943	3279	FP-5 Hose Coupling less A. A. R. Monogram, Complete		3-5/16	5-3/8	2-1/4
545525	538976	FP-5 Hose Coupling, Complete		3-5/16	5-3/8	2-1/4
551218	41817	FP-5 Hose Coupling, Complete		3-5/16	5-3/8	2-1/4
8326	2200	AL-3 Hose Coupling, Complete		3-1/4	4-5/16	2-1/2
22594	2200	AM-3 Hose Coupling, Complete		2-3/4	4-3/16	2-1/2
77292	3279	FS-3 Hose Coupling, Complete, Single Car Test Device		3-1/8	5-7/8	2-1/4
520491	3279	HS-3 Hose Coupling Complete, with .290 Choke		2-1/4	4-3/4	2-1/2
96892	3313	MK-3 Hose Coupling, Complete		2-5/8	5-3/8	3
13477	13475	NK-3 Hose Coupling, Complete		2-5/8	5-3/8	3
51793	13475	NK-3 Coupling, Complete		2-5/8	5-3/8	3
46346	3313	FL-4 Hose Coupling, Complete		4	5-3/16	2
45968	3279	FR-4 Hose Coupling with Shank at an 45° Angle		3-1/2	5-3/4	2
545506	538976	LS-4 Hose Coupling with Shank at an Angle		2-3/4	4-1/2	1-3/4
46344	3313	MK-4 Hose Coupling, Complete		2-3/4	5-1/8	3-1/4
46102	3279	HP-4 Hose Coupling, Complete		2-1/2	5-3/16	2
43005	3279	HP-4 Hose Coupling, Complete		2-1/2	5-3/16	2
529778	None	FP-5 Hose Coupling, Complete		3-5/16	5-3/8	2-1/4
46458	3279	FR-5 Hose Coupling, Complete		3-1/2	5-5/16	2-1/4
504513	3279	FS-5 Hose Coupling, Complete		3-1/2	6-1/4	2-1/2
556407	3279	HP-3 Hose Coupling, Complete		7-1/8	2-7/16	2

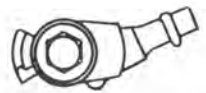

AL, FL, MK, NK



AY



AM



FR



AN

* Gaskets, Reference No. 3 are included in Complete Pc. Numbers

Prices will be quoted upon application
Orders should give PIECE NUMBER and NAME of part wanted

*DUMMY COUPLINGS

For Brake Pipe Hose Coupling
with Eye on back of Coupling

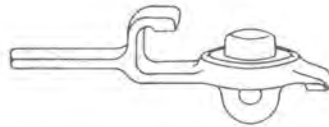

For Signal Pipe Hose Coupling
with Eye on end of handle



Pc. No.	Type	Approx. Net Weight Lbs.
20806	F.	5/8
20809	F with Chain	3/4
82974	F-1 (with Brass Insert).	3/4
87701	F-1 (with Brass Insert and 7-1/2" Chain).	1
554992	F-1 with 7-1/2" Chain.	
20816	E and L	1
20817	E and L with Chain.	1-1/8
505419	E and L (with Brass Insert).	1
512048	E and L (with Brass Insert & 7-1/2 Chain).	1-1/8
554994	E and L with 7-1/2" Chain.	1-1/8
508557	H-1 (with Brass Insert & 7-1/2 Chain).	1-1/4
20821	A with 7-1/2" Chain	1-1/4
20811	H with 7-1/2" Chain	1-1/8
81810	H with 14" Chain	1-1/4
73713	H with 23" Chain	1-3/4
510699	H with 21-7/8" Chain	1-1/2
20819	M with 7-1/2" Chain	1-1/8
33195	E & L Type with 12" Chain	1-1/2

Piece No. 2134 Type "H"

Pc. No.	Type	Approx. Net Weight Lbs.
2134	H.	1
18657	H with 7-1/2" Chain.	1-1/8
516237	H with 20" Chain	
516237	H-1 (with Brass Insert) 20" Chain.	1-1/2
508557	H-1 with 7-1/2" Chain.	

CLEANING TOOL

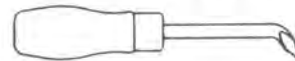

Approx. Net Weight 1/4 lb.
Piece No. 46096 Coupling
Groove Cleaning Tool

* Dummy Couplings can be used with any size of Hose Couplings in which the first letter in the designation is the same as the type letter of the dummy coupling.

MISCELLANEOUS

Angle Fittings

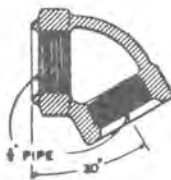

Fig. 1
Approx. Net Weight 5/8 lb.

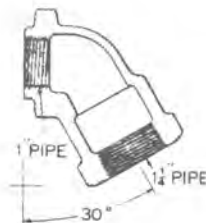

Fig. 2
Approx. Net Weight 2-1/2 lbs.

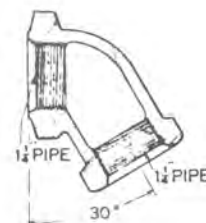

Fig. 3
Approx. Net Weight 3 lbs.

- Piece No. 2237 3/4" x 3/4" Angle Fitting, Fig. 1
- Piece No. 3819 1" x 1-1/4" Angle Fitting, Fig. 2
- Piece No. 3788 1-1/4" x 1-1/4" Angle Fitting, Fig. 3

Prices will be quoted upon application
Orders should give PIECE NUMBER and NAME of part wanted

HOSE COUPLINGS

MK-4 HOSE COUPLING

The MK-4 Hose Coupling, having automatic closing when uncoupled.

Piece No. 46344. MK-4 Hose Coupling, complete

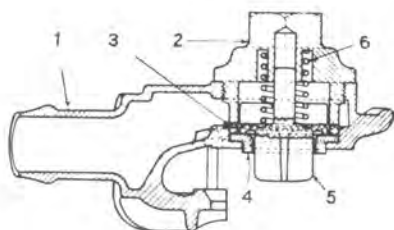

Pc. No.	Ref. No.	
4487	2	Cap
5760	3	Washer
3313	4	Hose Coupling Gasket
5759	5	Valve
5761	6	Spring

Approx. Net Wt. 3 lb.

FS-4 HOSE COUPLING

Pc. No. Ref. No.

88983		FS-4 Hose Coupling with shank, tapped for 1" pipe, complete (includes 3)
87737		FS-3 Hose Coupling, with shank, tapped for 3/4" pipe, complete (includes 3)
3279	3	Hose Coupling Gasket

Approx. Net Wt. 2-1/4 lb.

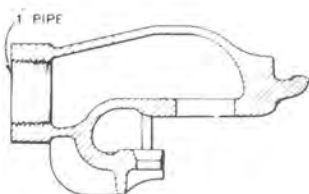
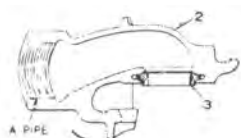

FV-4 CHARGING HOSE COUPLING

Supplied for Storage Brake Equipments

Piece No. 46246. FV-4 Charging Hose Coupling (tapped for 1" pipe) complete

Approx. Net Wt. 2-3/4 lb.

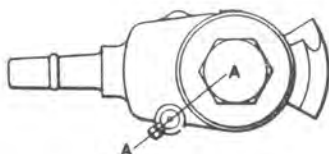

AY-2 HOSE COUPLING WITH LOCKING DEVICE

The AY-2 Hose Coupling has manually operated locking feature to prevent couplings from separating. (Will interchange with AM-2 Coupling).

Piece No. 22577. AY-2 (1/2") Hose Coupling, with Locking Device, complete

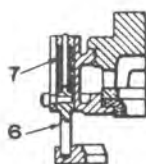
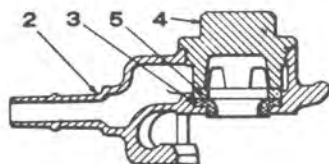

Pc. No.	Ref. No.	
58229	2	Hose Coupling Case, with Pin
2200	3	Hose Coupling Gasket
7969	4	Coupling Cap
2199	5	Coupling Gasket Washer
22576	6	Latch with Button, complete
22575	7	Latch Spring

Approx. Net Wt. 1-3/4 lb.

SECTION A-A

Prices will be quoted upon application
Orders should give PIECE NUMBER and NAME of part wanted

HOSE COUPLINGS

AM-2 HOSE COUPLING

The AM-2 Coupling will interchange with AY-2 Coupling.

Piece No. 10901, AM-2 (1/2") Hose Coupling, complete

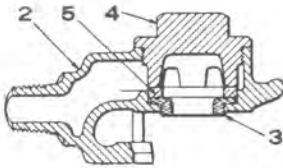

Pc. No.	Ref. No.	
5798 1	2	Hose Coupling Case, with Pin
2200	3	Hose Coupling Gasket
7969	4	Coupling Cap
2199	5	Coupling Gasket Washer

Approx. Net Wt. 2 lb.

DUST STOPPER

The E and L Dust Stopper is used with ET-3 and LT-3 Hose Couplings.

Piece No. 8496, E and L Dust Stopper

Approx. Net Wt.

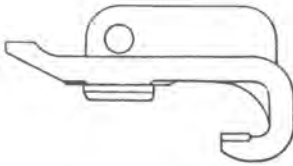

SPECIAL COUPLINGS

HUF HOSE COUPLING

The HUF Hose Coupling consists of a jumper or double end coupling with gaskets, one end suitable for coupling with the standard Signal Coupling, the other end suitable for coupling with the standard Brake Pipe Coupling, and was designed for the purpose of providing means for temporarily connecting the brake pipe and signal pipe in cases of emergency.

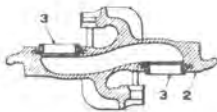

Pc. No.	Ref. No.	
46150	2	HUF Hose Coupling, complete, (includes two of 3)
3279	3	Hose Coupling Gasket (2 Req'd)

Approx. Net Weight,
each 4-1/4 lbs.

HP-4 AND FP-4 COMBINATION HOSE COUPLING

Piece No. 46322 One HP-4 and Two FP-4 Combination
Hose Coupling, complete, used with
Brake Test Truck, see Part Catalog
3219-1 Sup. 6.



Approx. Net Weight, each 6-1/2 lbs.

Prices will be quoted upon application
Orders should give PIECE NUMBER and NAME of part wanted

EYS-2 HOSE COUPLING

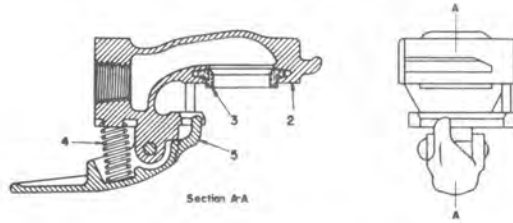

Pc. No.	Ref. No.	Part Name
538551		EYS-2 Hose Coupling, Complete, with Locking Handle
538552	2	Coupling Case
538976	3	Coupling Gasket
540464	4	Handle Spring
540458	5	Handle

Approx. Net Wt. - 3 lb.

OJ-2 AND ON-2 HOSE COUPLINGS

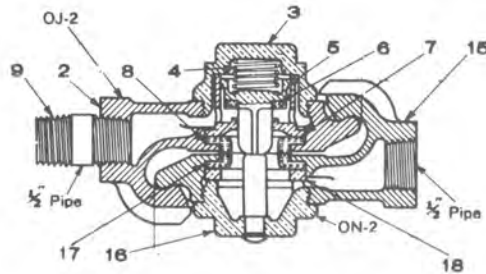

Pc. No.	Ref. No.	Part Name
87762		OJ-2 Hose Coupling, Complete
81462	2	Coupling Case
87761	3	Valve Cap Nut
87760	4	Valve Spring
87724	5	Valve Stem
17550	6	Valve Seal
87723	7	Valve Bushing
2200	8	Coupling Gasket
81465	9	1/2" x 1-1/2" Nipple
87772		ON-2 Hose Coupling, Complete
81462	15	Coupling Case
87765	16	Cap Nut
2200	17	Coupling Gasket
87766	18	Gasket Washer

OJ - Approx Net Wt. 1-3/4 lb.

ON - Approx. Net Wt. - 1-1/2 lb.

Prices will be quoted upon application
 Orders should give PIECE NUMBER and NAME of part wanted

MISCELLANEOUS

3216-3

HOSE FITTINGS

1/4 Wabco Hose

Pc. No.	Description	A
38021	1/4 Threaded Nipple	1-3/16
79533	1/4 Tapped Nipple	5/8
547779	Punch Lok Clamp	
550391	1/4 Flanged Nipple	3/8
96826	1/4 Threaded Nipple	1-3/16

3/8 Wabco Hose

Pc. No.	Description	A
53975	3/8 Threaded Nipple	1-1/16
57116	3/8 Tapped Nipple	7/8
541699	1/2 Tapped Nipple	1
544803	3/8 Tapped Union Nipple	1-1/16
530856	3/8 Flanged Nipple	7/8
542883	Punch Lok Clamp	
553641	3/8 Thrd. Union Nipple	2-13/32

1/2 Wabco Hose

Pc. No.	Description	A	B	C
6390	1/2 Threaded Nipple	1-1/8		
11514	3/4 Threaded Nipple	1-3/16		
44277	1/2 Tapped Nipple	1		
71979	3/8 Threaded Nipple	1-1/8		
80003	1/2 Th'd. Nipple & Choke	1-1/8		
504091	3/8 Flanged Nipple	23/32		
512301	1/2 Flanged Angle Nipple	13/16	11/16	60°
512493	1/2 Th'd. Nipple & Choke	1-1/8		
544804	3/8 Tapped Union Nipple	1-3/4		
544805	1/4 Tapped Union Nipple	1-9/16		
544806	1/2 Tapped Union Nipple	1-15/16		
550119	1/2 Threaded Union Nipple	2-11/16		
547040	Punch Lok Clamp			

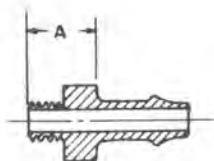

Threaded Stud Nipple

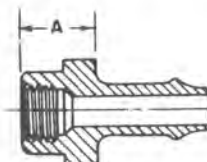

Tapped Nipple

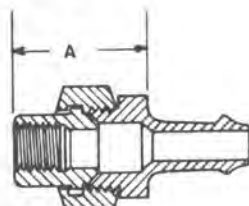

Tapped Union Nipple

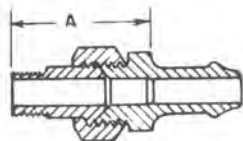

Threaded Union Nipple

Prices will be quoted upon application

Orders should give PIECE NUMBER and NAME of part wanted

5/8 Wabco Hose

Pc. No.	Description	A	B
532836	1/2 Tapped Nipple	1	
532838	1/2 Threaded Nipple	1-1/8	
533040	3/4 Tapped Nipple & Choke	31/32	
533041	3/4 Flanged Nipple	1/2	
533446	1/2 Tapped Union Nipple	1-15/16	
537451	3/4 Flanged Elbow Nipple	1-1/16	1
546405	1/2 Threaded Union Nipple	2-11/16	
550107	3/4 Threaded Hose Nipple	1-3/16	
541051	Punch Lok Clamp		

3/4 Wabco Hose

Pc. No.	Description	A
7968	3/4 Threaded Nipple	1-3/16
8417	1/2 Threaded Nipple	1-3/16
14773	3/4 Tapped Nipple	1
15229	1 Tapped Nipple	1-3/16
47811	1 Threaded Nipple	1-11/16
48378	1/2 Tapped Nipple	1
534318	3/4 Threaded Union Nipple	3-3/32
541765	3/4 Tapped Union Nipple	2-1/4
543138	1/2 Th'd. Nipple & Choke	1-3/16
544807	1 Tapped Union Nipple	3-7/32
544808	1/2 Tapped Union Nipple	1-15/16
545657	1/2 Threaded Union Nipple	2-11/16
547647	3/8 Threaded Nipple	1-5/16
541051	Punch Lok Clamp	

MISCELLANEOUS

HOSE FITTINGS

7/8 Wabco Hose

Pc. No.	Description	A
532839	3/4 Threaded Nipple	1-3/16
533508	3/4 Tapped Union Nipple	2-1/4
532837	3/4 Tapped Nipple	31/32
532842	3/4 Flanged Nipple	1/2
537001	3/4 Threaded Union Nipple	3-3/32
541052	Punch Lok Clamp	

1-1/8 Wabco Hose

Pc. No.	Description	A	B	C
46162	1 Tapped Angle Nipple	5/8	1-1/2	60°
46164	1-1/4 Threaded Nipple	1-25/32		
46169	3/4 Threaded Nipple	1-1/2		
46170	3/4 Tapped Angle Nipple	1/2	1	45°
46175	1 Threaded Nipple	1-25/32		
46178	3/4 Tapped Nipple	1-1/8		
46180	1 Tapped Nipple	1-3/16		
506472	3/4 Flanged Nipple	2-15/16		
511388	1/2 Tapped Nipple	15/16		
534317	1 Threaded Union Nipple	3-11/32		
544810	3/4 Tapped Union Nipple	2-3/16		
544811	3/4 Threaded Union Nipple	3-1/32		
544812	1/2 Tapped Union Nipple	2-1/4		
544813	1/2 Threaded Union Nipple	3		
544814	1 Tapped Union Nipple	2-7/16		
544815	1-1/4 Tapped Union Nipple	2-5/8		
546877	1 Tapped Union Nipple	2-7/16		
547624	1 Flanged Nipple	9/16		
547625	1 Flanged Elbow Nipple	1-3/8	1-5/16	
530436	Wire Hanger			
539322	Punch Lok Clamp			

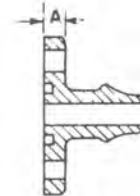

Flanged Nipple

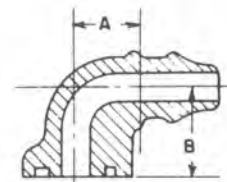

Flange Elbow Nipple

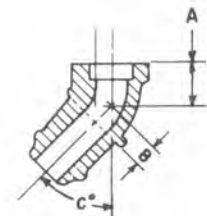

Flanged Angle Nipple

1-3/8 Wabco Hose

Pc. No.	Description	A	B	C
46223 *	1-1/4 Threaded Nipple	1-13/16		
46272	1 Threaded Nipple	1-3/4		
46273	1-1/4 Tapped Nipple	1-3/8		
46224	3/4 Tapped Angle Nipple	1/2	1	45°
81718	1-1/4 Tapped Angle Nipple	3/4	1-9/16	60°
82998	1-1/2 Threaded Nipple	1-13/16		
508960	1-1/4 Flanged Angle Nipple	1-3/8	3/4	60°
544816 *	1 Tapped Union Nipple	2-5/16		
532825	1-1/4 Threaded Nipple	1-13/16		
532843	1-1/4 Flanged Nipple	5/8		
532844	1-1/4 Tapped Union Nipple	2-3/4		
533523	1-1/4 Flanged Elbow Nipple	1-3/8	2-5/8	
534679	1-1/4 Tapped Nipple	1-3/8		
537003	1-1/4 Threaded Union Nipple	3-3/4		
547960 *	1-1/4 Threaded Union Nipple	2-3/4		
539321	Punch Lok Clamp			
512752	1-1/8 Annealed Steel Hose Clamp (Comp.)			

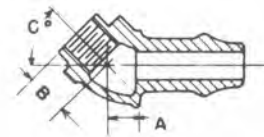

Tapped Angle Nipple

Prices will be quoted upon application

Orders should give PIECE NUMBER and NAME of part wanted

* NOTE - A. A. R. Recommended

ANGLE FITTINGS WITH REINFORCED FLANGED UNION AND SUPPORTING LUG

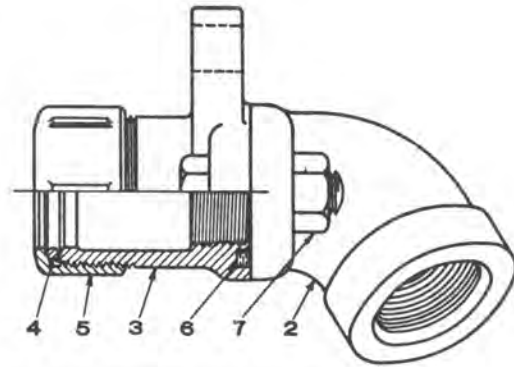
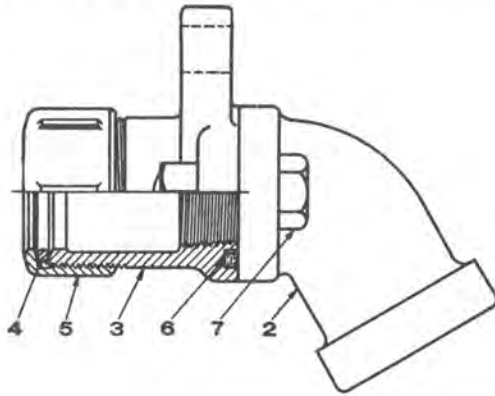

Pc. No.	506776	511417	508578	506777	511416
Approx. Weight Lbs.	6 7/8	6 7/8	5	2 7/8	2 7/8

- Piece No. 506776 1 1/4" Angle Fitting with 1 1/4" Reinforced Flanged Union Fitting, complete
- Piece No. 511417 1 1/4" Angle Fitting having Pipe Connection at 30° with 1 1/4" Reinforced Flanged Union, complete
- Piece No. 508578 1" Angle Fitting with 1" Reinforced Flanged Union Fitting, complete
- Piece No. 506777 3/4" Angle Fitting with 3/4" Reinforced Flanged Union Fitting, complete
- Piece No. 511416 3/4" Angle Fitting having Pipe Connection at 30° with 3/4" Reinforced Flanged Union Fitting, complete

- Pc. No. Ref. No.
- 506775 2 1 1/4" Angle Fitting Body
 - 511402 2 1 1/4" Angle Fitting Body with Pipe Connection at 30°
 - 508726 2 1" Angle Fitting Body
 - 506774 2 3/4" Angle Fitting Body
 - 511415 2 3/4" Angle Fitting Body with Pipe Connection at 30°
 - 511563 1 1/4" Reinforced Flanged Union, complete (includes 3, 4 and 5)
 - 511564 1" Reinforced Flanged Union, complete (includes 3, 4 and 5)
 - 511561 3/4" Reinforced Flanged Union, complete (includes 3, 4 and 5)
 - 511329 3 Flanged Union Body for 1 1/4" Pipe
 - 511546 3 Flanged Union Body for 1" Pipe

- Pc. No. Ref. No.
- 511469 3 Flanged Union Body for 3/4" Pipe
 - 94789 4 Flanged Union Ring for 1 1/4" Pipe
 - 93987 4 Flanged Union Ring for 1" Pipe
 - 93838 4 Flanged Union Ring for 3/4" Pipe
 - 94788 5 Flanged Union Nut for 1 1/4" Pipe
 - 93988 5 Flanged Union Nut for 1" Pipe
 - 93833 5 Flanged Union Nut for 3/4" Pipe
 - 94790 6 1 1/4" Flanged Union Gasket
 - 93986 6 1" Flanged Union Gasket
 - 93841 6 3/4" Flanged Union Gasket
 - 21800 7 Hex. Hd. Bolt and Nut (2 Req'd) for 1 1/4" Fittings
 - 10834 7 Hex. Hd. Bolt and Nut (2 Req'd) for 1" Fittings
 - 21366 7 Hex. Hd. Bolt and Nut (2 Req'd) for 3/4" Fittings

PIPE SUPPORT FITTINGS

60° Angle Bracket Coupling

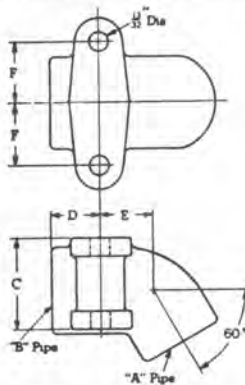

90° Angle Bracket Coupling

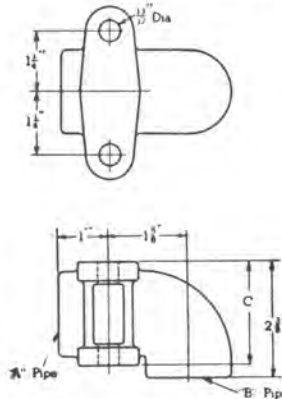

Straight Bracket Coupling

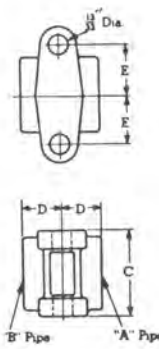

Straight Bracket Coupling

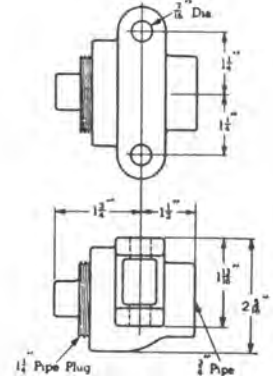

Size	Pc. No.	A	B	C	D	E	F
1" x 1"	503807	1"	1"	1 7/8"	1"	1 1/4"	1 1/4"
1" x 1 1/4"	503806	1 1/4"	1"	1 7/8"	1"	1 1/8"	1 1/4"
1" x 1 1/2"	*504819	1 1/2"	1"	1 7/8"	1"	1 1/8"	1 1/4"
3/4" x 3/4"	98474	3/4"	3/4"	1 1/8"	H"	H"	1"
1/2" x 1/2"	98845	1/2"	1/2"	1 1/8"	3/4"	7/8"	3/8"
1/2" x 3/8"	99084	1/2"	3/8"	1 1/8"	3/4"	7/8"	3/8"

Size	Pc.No.	A	B	C
1 1/4" x 1 1/4"	507494	1 1/4"	1 1/4"	2 H"
1" x 1"	505075	1"	1"	2 1/2"
1" x 1"	506228	1"	1"	2 1/2"
3/4" x 3/4"	506229	3/4"	3/4"	2 1/2"
1/2" x 1/2"	506230	1/2"	1/2"	2 1/2"

Size	Pc.No.	A	B	C	D	E
1 1/4" x 1 1/4"	509481	1 1/4"	1 1/4"	2 3/4"	1"	1 1/8"
1" x 1 1/4"	505088	1 1/4"	1"	2 3/4"	1"	1 1/8"
1" x 1"	500727	1"	1"	2 3/4"	1"	1 1/8"
1/2" x 3/4"	505093	3/4"	1/2"	1 1/4"	H"	1"
1/2" x 1/2"	505087	1/2"	1/2"	1 1/4"	3/4"	3/8"

Pc. No. 98847 3/4" x 1 1/4" Straight Bracket Coupling

Pc. No. 98477 3/4" x 1 1/4" Straight Bracket Coupling with 1 1/4" Pipe Plug

*Pc. 504819 includes 1 1/2" Pipe Plug

Prices will be quoted upon application

Orders should give PIECE NUMBER and NAME of part wanted

Westinghouse Air Brake Company

Wilmerding, Pa., U. S. A.



Cut-Out Cocks (Tapped)

Part Catalog No. 3216-4

March, 1950

(SUPERSEDING PORTION OF JANUARY, 1938 ISSUE OF 3216-4, PORTION OF
T-3516-4 AND TEMPORARY PART CATALOG T-3516-4, SUP. 10)

CUT-OUT COCKS
INDEX TO COMPLETE PIECE NUMBERS

Pc. No.	Cock Size	Page	Pc. No.	Cock Size	Page	Pc. No.	Cock Size	Page
17921	1/4"	3	64596	1 1/2"	9	31269	1"	4
51320	1/4"	3	70579	1 1/2"	9	33073	1"	6
84447	1/4"	3	72401	1 1/2"	9	33894	1"	11
501100	1/4"	3	99085	1 1/2"	3	43004	1"	4
501101	1/4"	3	501083	1 1/2"	3	45757	1"	5
501103	1/4"	3	501084	1 1/2"	3	50772	1"	5
520647	1/4"	14	501085	1 1/2"	3	51288	1"	8
520850	1/4"	14	501086	1 1/2"	3	51299	1"	8
522499	1/4"	14	501087	1 1/2"	3	55749	1"	9
9053	3/8"	3	508626	1 1/2"	7	59369	1"	11
12260	3/8"	3	513931	1 1/2"	3	66500	1"	5
22459	3/8"	3	516230	1 1/2"	3	90562	1"	9
35725	3/8"	3	519840	1 1/2"	3	505074	1"	5
51302	3/8"	8	520445	1 1/2"	3	508620	1"	7
57102	3/8"	3	526382	1 1/2"	14	524607	1"	4
59090	3/8"	11	532944	1 1/2"	14	526374	1"	4
66448	3/8"	8	535343	1 1/2"	7	533919	1"	5
68334	3/8"	8	2233	3/4"	4	536187	1"	4
74319	3/8"	3	7517	3/4"	8	2092	1 1/4"	4
75588	3/8"	10	11823	3/4"	4	20260	1 1/4"	4
84492	3/8"	8	14494	3/4"	4	27415	1 1/4"	4
90772	3/8"	9	19709	3/4"	4	33072	1 1/4"	6
91148	3/8"	8	20263	3/4"	8	67190	1 1/4"	4
500291	3/8"	3	29723	3/4"	8	75653	1 1/4"	4
501042	3/8"	3	29724	3/4"	8	79885	1 1/4"	4
501065	3/8"	3	30436	3/4"	4	84458	1 1/4"	11
501066	3/8"	3	43286	3/4"	4	85647	1 1/4"	11
501070	3/8"	3	54499	3/4"	10	97290	1 1/4"	5
504746	3/8"	11	55747	3/4"	9	508625	1 1/4"	7
512087	3/8"	11	59088	3/4"	11	510728	1 1/4"	4
512302	3/8"	11	64727	3/4"	8	517302	1 1/4"	7
512438	3/8"	3	65536	3/4"	8	517357	1 1/4"	7
516933	3/8"	7	67128	3/4"	9	518235	1 1/4"	4
523369	3/8"	14	75587	3/4"	9	521825	1 1/4"	7
523370	3/8"	14	91134	3/4"	10	530537	1 1/4"	5
529761	3/8"	3	99081	3/4"	4	532576	1 1/4"	7
536824	3/8"	3	501074	3/4"	4	18409	1 1/2"	4
540354	3/8"	3	501076	3/4"	4	64790	1 1/2"	4
900200	3/8"	10	501077	3/4"	4	84234	1 1/2"	4
901310	3/8"	10	501078	3/4"	4	9530	2"	4
901631	3/8"	6	508627	3/4"	7	79646	2"	4
901632	3/8"	6	519844	3/4"	4	9517	3/8" and 1"	12
12603	1 1/2"	3	520300	3/4"	4	11661	3/8" and 1"	12
14493	1 1/2"	3	524487	3/4"	9	51018	3/8" and 1"	12
15213	1 1/2"	3	530793	3/4"	14	530086	3/8" and 1"	12
18078	1 1/2"	3	2135	1"	4	84628	1 1/2" and 1 1/2"	12
29725	1 1/2"	8	11905	1"	5	521641	1 1/2" and 1 1/2"	12
30433	1 1/2"	3	19991	1"	5	528283	1 1/2" and 3/4"	13
43287	1 1/2"	3	20870	1"	4	69655	1 1/2" x 1"	13
44001	1 1/2"	3	21979	1"	5	519407	3/8" x 1"	13
59089	1 1/2"	11	26693	1"	4			

Prices will be quoted upon application

Orders should give PIECE NUMBER and NAME of part wanted

CUT-OUT COCKS

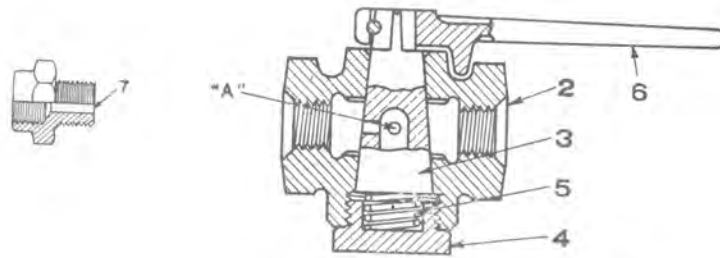

Cock Size	Complete	Vent Size "A"	Ref. No.								Approx. Net Weight (Lbs.)	
			2		3		4	5	6			7
			Body	Body With Vent	Key	Key With Vent	Cap	* Spring	Handle			Choke Fitting
								Split	Non-Split			
1/4"	51320		51311		9056		88064	2231				1 1/4
	501103		51311		9056		88064	2231		9035		
	17921	1/8"		17920			12259	88064	2231	9035		
	84447	1/16"		84422			84400	88064	2231	9035		
	501100	1/16"		84422			84400	88064	2231	99224		
	501101	1/8"		17920			12259	88064	2231	99224		
3/8"	9053		9055		9056		88064	2231		9035		1 1/4
	††22459		9055		9056		88064	2231	533456			
	500291		9055		9056		88064	2231	99224			
	§501042		501040		9056		88064	2231		501041		
	†529761		901626		9056		88064	2231	513907			
	†540354		901626		9056		88064	2231		501041		
	12260	1/8"		12258		12259	88064	2231		9035		
	35725	1/16"		35724		35723	88064	2231		9035		
	57102	1/16"		57103		57104	88064	2231		9035		
	††74319	1/8"		12258		12259	88064	2231	533456			
	501065	1/8"		12258		12259	88064	2231	99224			
	501066	3/16"		35724		35723	88064	2231	99224			
	501070	1/16"		57103		57104	88064	2231	99224			
	512438	1/16"		504744		512435	88064	2231	99224			
	†536824	1/8"		536823		12259	88064	2231	513907			
1/2"	14493		2228		2229		88064	2231		9035	11645	1 3/4
	15213		2228		2229		88064	2231		9035		1 1/2
	†18078		2228		2229		88064	2231		18036		1 1/2
	99085		2228		2229		88064	2231	99224			1 1/2
	501083		2228		2229		88064	2231	99224			1 1/2
	†513931		513930		2229		88064	2231	99224		11645	1 3/4
	12603	1/8"		30439		12601	88064	2231	513907			1 1/2
	30433	1/16"		30439		30440	88064	2231		9035		1 1/2
	43287	1/8"		43078		43079	88064	2231		9035		1 1/2
	44001	1/8"		30439		43969	88064	2231		9035		1 1/2
	501084	1/8"		30439		12601	88064	2231	99224			1 1/2
	501085	1/16"		30439		30440	88064	2231	99224			1 1/2
	501086	1/8"		43078		43079	88064	2231	99224			1 1/2
	501087	1/8"		30439		43969	88064	2231	99224			1 1/2
	519840	3/16"		30439		30440	88064	2231	99224			1 1/2
	520445	1/16"		518593		518594	88064	2231	99224		11645	1 3/4
	†516230	1/8"		516227		12601	88064	2231	513907			1 1/2

§Sealed in closed position

†Sealed in open position

‡Stub Handle

††Short Handle

*NOTE A—For Spring Identification Table, see page 14.

NOTE B—For Packaging, see page 15.

NOTE C—For Cut-out Cocks with Threaded and Tapped Connections, see Drain (Cut-out) Cocks P.C. 3216-4, Sup. 7.

Prices will be quoted upon application

Orders should give PIECE NUMBER and NAME of part wanted

CUT-OUT COCKS

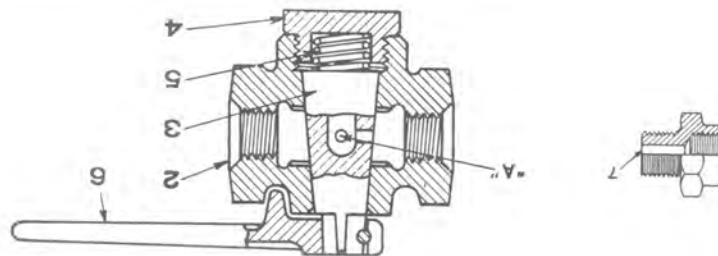

Cock Size	Complete	Vent Size (A)	2		3		4		5		6		7		
			Body	With Vent	Key	With Vent	Cap	Spring	Handle	Non-Split	Fitting	Choke	Net Weight (lbs.)	Approx.	
2"	1 1/2"	1 1/8"	9530	79646	9526	79645	9527	9529	9528	9528	18407	18407	18407	18407	18407
			18410	84244	18405	84232	18408	2098	2098	2098	2098	2098	2098	2098	2098
1 1/2"	1 1/4"	1 1/8"	2092	20260	2093	2096	2097	2098	2100	2100	2100	2100	2100	2100	2100
			2093	2093	2096	2096	2097	2098	2098	2098	2098	2098	2098	2098	2098
1"	3/4"	3/8"	2136	2136	2139	2139	2140	2098	2103	2103	2103	2103	2103	2103	2103
			2136	2136	2139	2139	2140	2098	2098	2098	2098	2098	2098	2098	2098
3/4"	3/8"	3/8"	2235	2235	2236	2236	2236	2236	2236	2236	2236	2236	2236	2236	2236
			2235	2235	2236	2236	2236	2236	2236	2236	2236	2236	2236	2236	2236
3/4"	3/8"	3/8"	501077	501078	30442	30443	94297	520304	99210	99210	99210	99210	99210	99210	99210
			501078	519844	30442	30443	94297	520304	99210	99210	99210	99210	99210	99210	99210

‡Stub Handle †Short Handle **Key with Spiral Side Vent

*NOTE A—For Spring Identification Table, see page 14.

NOTE B—For Packaging, see page 15.

NOTE C—For Cut-out Cocks with Threaded and Tapped Connections, see Drain (Cut-out) Cocks P.C. 3216-4 Sup. 7.

Prices will be quoted upon application

Orders should give PIECE NUMBER and NAME of part wanted

**CUT-OUT COCKS
MAIN RESERVOIR COCKS**

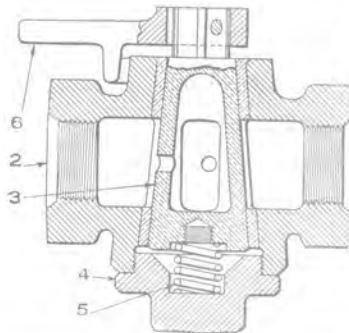

Cock Size	Complete	Vent Size	Ref. No.					Union Stud Connection	Approx. Net Weight (Lbs.)
			2	3	4	5	6		
			Body With Vent	Key With Vent	Cap	* Spring	Handle Non-Split		
1"	11905	1/4" Drill	11906	11909	2097	2098	11667	8	
	21979	1/4" Drill	63316	11909	2097	2098	11667	8 1/4	
	45757	1/4" Drill	63316	11909	2097	2098	11667	8	
	†50772	1/4" P.T.	56471	11909	2097	2098	11667	8	
	†19991	1/4" Drill	11906	11909	2097	2098	19704	8	
	††505074 533919	1/4" P.T. 1/4" Drill	56471 534260	11909 534259	2097 2097	2098 2098	19704 11667	8 8	
1 1/4"	97290	1/4" Drill	97289	97291	2097	2098	97287	8 1/2	
	†530537	1/4" P.T.	530541	97291	2097	2098	97287		

†Long Handle

††Side Vent Tapped for 1/4" Pipe

UNION STUD CONNECTION

Complete	Hole "A"	Ref. No.		
		202	203	204
		Stud	Nut	Sleeve
71713	5/16"	71730	71728	71727
86773	1/16"	86772	71728	71727
87805	3/2"	87804	71728	71727

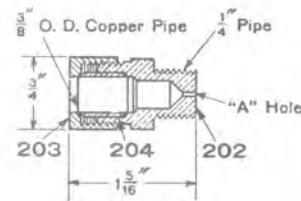

Approx. Net Weight 1/8 lb.

BRAKE PIPE CUT-OUT COCK

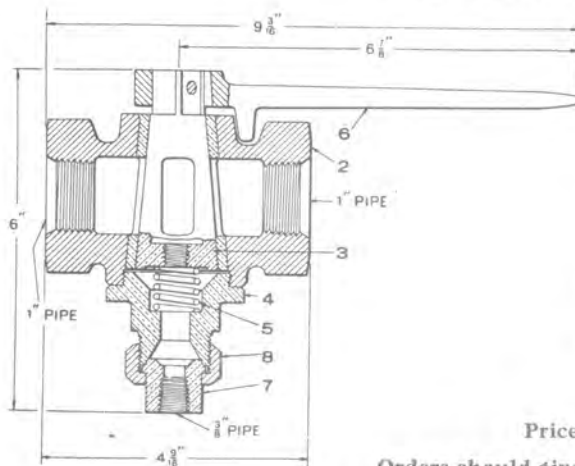

Piece No. 66500 1" Cut-out Cock, Complete

Pc. No.	Ref. No.
2136	2 Body
2139	3 Key
63929	4 Cap
*2098	5 Spring
2103	6 Handle
37625	7 Swivel
15292	8 Nut

Approx. Net Weight 7 3/4 Lbs.

*NOTE A—For Spring Identification Table, see page 14.
NOTE B—For Packaging, see page 15.

Prices will be quoted upon application
Orders should give PIECE NUMBER and NAME of part wanted

CUT-OUT COCKS

3/8" CUT-OUT COCK WITH COCK SUPPORT AND HANDLE SEALED IN OPEN POSITION

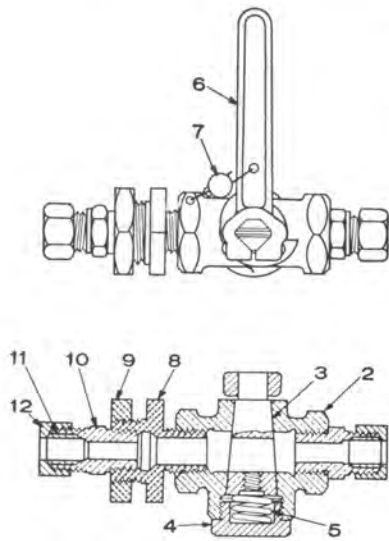

Piece No. 901631 3/8" Cut-out Cock, Complete
 Piece No. 901632 3/8" Cut-out Cock, Less Compression Fittings

Pc. No.	Ref. No.
901626	2 Body
9056	3 Key
88064	4 Cap
*2231	5 Spring
513907	6 Handle
	7 Seal with Wire 12 1/2" Long
95872	Support Fitting Complete (includes 8 and 9)
95826	8 Support Fitting
95827	9 Jam Nut
84157	3/8" Compression Union Stud, Complete (2 Req'd) (includes 10, 11 and 12)
80677	10 Stud (2 Req'd)
71727	11 Sleeve (2 Req'd)
71728	12 Nut (2 Req'd)

Approx. Net Weight 1 1/2 Lbs.
 Approx. Net Weight, Less Fittings 1 1/4 Lbs.

CUT-OUT COCKS WITH STRAIGHT LOCK HANDLE

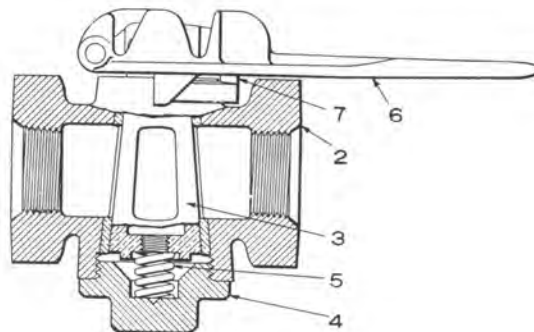

Cock Size	Com- plete	Ref. No.							Approx. Net Weight (Lbs.)
		2 Body	3 Key	4 Cap	5 * Spring	Handle Comp. Includes 6 and 7	6 Handle	7 Handle Socket	
1"	33073	2136	2139	2140	2098	32930	32928	32929	6 1/4
1 1/4"	33072	2093	2096	2097	2098	37691	37687	37688	9 1/4

*NOTE A—For Spring Identification Table, see page 14.

NOTE B—For Packaging, see page 15.

Prices will be quoted upon application
 Orders should give PIECE NUMBER and NAME of part wanted

CUT-OUT COCKS
CUT-OUT COCKS WITH LOCKING HANDLE

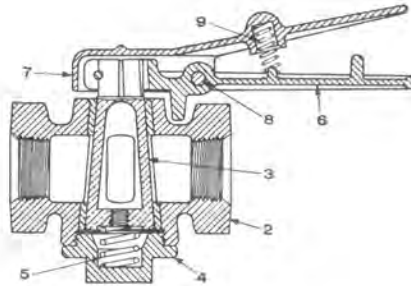

Cock Size	Complete	Ref. No.									Approx. Net Weight (Lbs.)
		2	3	4	5	Handle Complete	6	7	8	9	
		Body	Key	Cap	* Spring		Handle	Handle Lock	Pin	* Handle Spring	
3/8"	516933	9055	9056	88064	2231	512851	510923	510924	510925	13109	1 5/8
1/2"	508626	2228	2229	88064	2231	512851	510923	510924	510925	13109	2 1/4
	†535343	30439	12601	88064	2231	512851	510923	510924	510925	13109	
3/4"	508627	2235	2236	94297	2145	512852	510926	510927	510928	13109	3 1/2
1"	508620	2136	2139	2140	2098	512853	510930	510931	510932	11730	7
1 1/4"	508625	2093	2096	2097	2098	512854	510933	510934	510932	11730	9 1/2
	‡521825	518439	518440	2097	2098	512854	510933	510934	510932	11730	
	§532576	2093	7839	70727	2098	512854	510933	510934	510932	11730	

† 1/8" Vent

‡ 1/4" Spiral Side Vent

§ Vent in Cap

1 1/4" CUT-OUT COCK WITH LOCKING HANDLE PARALLEL WITH PIPE WHEN OPEN

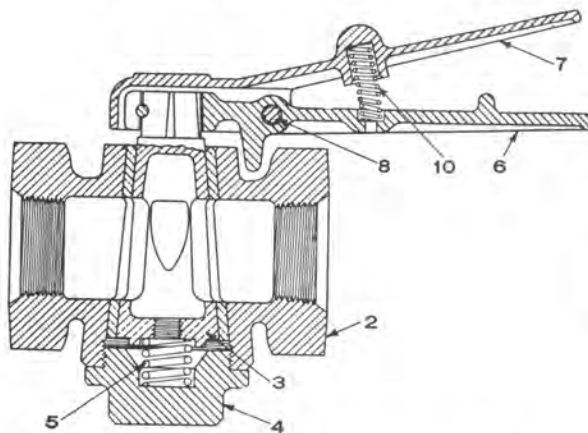

Piece No. 517302 1 1/4" Cut-out Cock, Complete
 Piece No. 517357 1 1/4" Cut-out Cock, Complete, Less Handle

Pc. No.	Ref. No.	Description
2093	2	Body
515301	3	Key
2097	4	Cap
*2098	5	Spring
515322		Handle, complete (includes 6, 7, 8 and 9)
517301	6	Handle
515307	7	Handle Lock
510932	8	Pin
11730	10	Handle Spring

Approx. Net Weight 9 1/4 Lbs.
 Approx. Net Weight, Less Handle 7 3/4 Lbs.

*NOTE A—For Spring Identification Table, see page 14.
 NOTE B—For Packaging, see page 15.

Prices will be quoted upon application
 Orders should give PIECE NUMBER and NAME of part wanted

CUT-OUT COCKS
TEST RACK COCKS

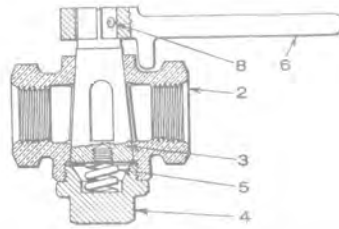

Cock Size	Complete	Ref. No.								Choke Plug	Approx. Net Weight (Lbs.)	
		Vent Size	2		3		4	5	6			8
			Body	Body With Vent	Key	Key With Vent	Cap	* Spring	Handle			Cotter
3/8"	51302		9055		9056		88064	2231	9035	12270	84493 (3/8" Drill) 50716 (1/4" Drill)	1 3/8
	84492		9055		9056		88064	2231	9035	12270		
	91148		9055		9056		88064	2231	9035	12270		
1/2"	29725		2228		2229		88064	2231	9035	12270		1 1/2
	29724		2235		2236		94297	520304	15279	8049		2 1/2
3/4"	17517	1/8"		7515		7516	94297	520304	26127	8049		2 1/2
	20263	1/8"		7515		7516	94297	520304	18762	8049		2 1/2
	29723		2235		2236		94297	520304				2 1/8
1"	51288		2136		2139		2140	2098	2103	41334		5 1/2
	51299	1/8"		57111		43003	2140	2098	2103	41334		

†Handle Bent on Angle

†Piece No. 66448 3/8" Cock, Complete

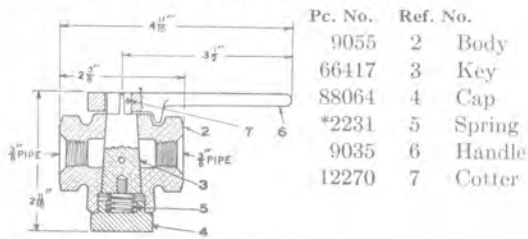

Pc. No.	Ref. No.	Description
9055	2	Body
66417	3	Key
88064	4	Cap
*2231	5	Spring
9035	6	Handle
12270	7	Cotter

Approx. Net Weight 1 3/8 Lbs.

†Piece No. 68334 3/8" Cock, Complete

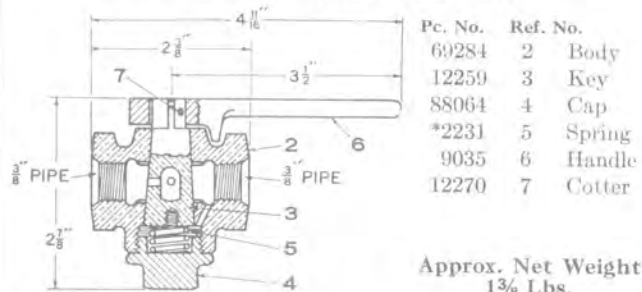

Pc. No.	Ref. No.	Description
69284	2	Body
12259	3	Key
88064	4	Cap
*2231	5	Spring
9035	6	Handle
12270	7	Cotter

Approx. Net Weight 1 3/8 Lbs.

†Piece No. 6472 3/4" Cock, Complete

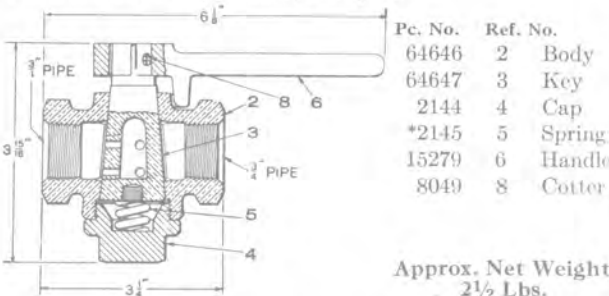

Pc. No.	Ref. No.	Description
64646	2	Body
64647	3	Key
2144	4	Cap
*2145	5	Spring
15279	6	Handle
8049	8	Cotter

Approx. Net Weight 2 1/2 Lbs.

†Piece No. 65536 3/4" Cock, Complete

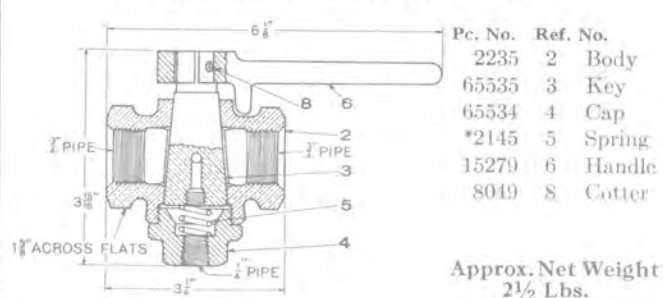

Pc. No.	Ref. No.	Description
2235	2	Body
65535	3	Key
65534	4	Cap
*2145	5	Spring
15279	6	Handle
8049	8	Cotter

Approx. Net Weight 2 1/2 Lbs.

*NOTE A—For Spring Identification Table, see page 14.

NOTE B—For Packaging, see page 15.

†NOTE C—Listed for detail repairs only, complete cocks will not be furnished.

Prices will be quoted upon application
Orders should give PIECE NUMBER and NAME of part wanted

CUT-OUT COCKS
CUT-OUT COCKS FOR DRAWBAR CONNECTION

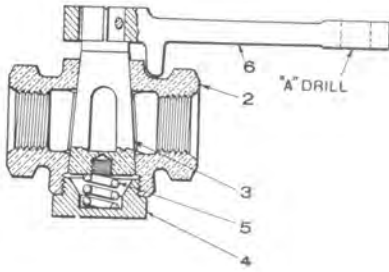

Cock Size	Comp.	Ref. No.						Approx. Net Weight (Lbs.)
		2	3	4	5	6		
		Body	Key	Cap	Spring	Handle	A	
3/8"	90772	9055	9056	88064	2231	64597	1/2"	1 1/4
1/2"	64596	2228	2229	88064	2231	64597	1/2"	1 1/2
	72401	2228	2229	88064	2231	516538	7/16"	
	70579	2228	2229	88064	2231	70574	1/16"	
3/4"	55747	2235	2236	94297	2145	55746	1/2"	2 1/2
1"	55749	2136	2139	2140	2098	55748	1/2"	5 1/2

3/4" CUT-OUT COCKS FOR DRAWBAR CONNECTION, WITH HANDLE ON ANGLE

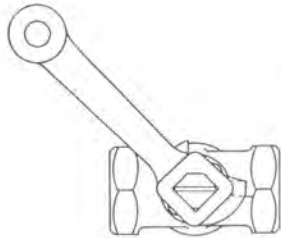

Piece No. 67128 3/4" Cut-out Cock, Complete

Pc. No.	Ref. No.	
2235	2	Body
2236	3	Key
94297	4	Cap
*2145	5	Spring
67127	6	Handle

Approx. Net Weight
2 1/2 Lbs.

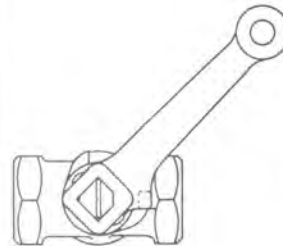
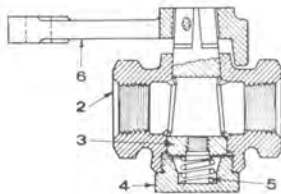

Piece No. 524487 3/4" Cut-out Cock, Complete

Pc. No.	Ref. No.	
2235	2	Body
2236	3	Key
94297	4	Cap
*2145	5	Spring
524486	6	Handle

Approx. Net Weight
2 1/2 Lbs.

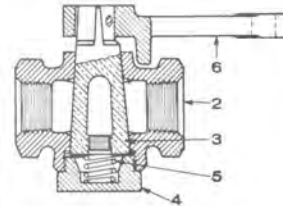

3/4" CUT-OUT COCK WITH DOUBLE END HANDLE

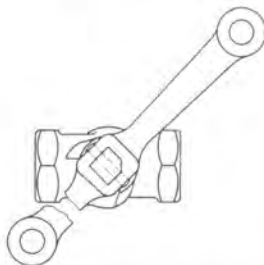

Piece No. 75587 3/4" Cut-out Cock, Complete

Pc. No.	Ref. No.	
2235	2	Body
2236	3	Key
94297	4	Cap
*2145	5	Spring
75943	6	Handle

Approx. Net Weight
3 Lbs.

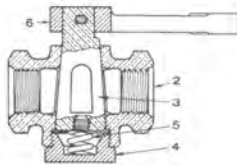

1" CUT-OUT COCK WITH OFFSET HANDLE

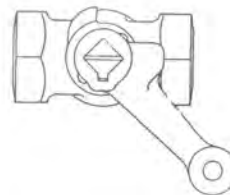

Piece No. 90562 1" Cut-out Cock, Complete

Pc. No.	Ref. No.	
2136	2	Body
2139	3	Key
2140	4	Cap
*2098	5	Spring
90548	6	Handle

Approx. Net Weight
5 3/4 Lbs.

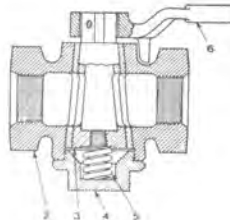

*NOTE A—For Spring Identification Table, see page 14.
 NOTE B—For Packaging, see page 15.

Prices will be quoted upon application
 Orders should give **PIECE NUMBER** and **NAME** of part wanted

CUT-OUT COCKS

3/8" CUT-OUT COCK WITH HANDLE HAVING EYE



Piece No. 75588 3/8" Cut-out Cock, Complete

Pc. No.	Ref. No.	
35724	2	Body, with 3/16" Vent
35723	3	Key, with 3/16" Vent
*2231	4	Spring
88064	5	Cap
75944	6	Handle

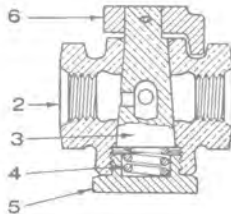

Approx. Net Weight 1 3/4 Lbs.

3/4" CUT-OUT COCKS WITH SPECIAL STOP ON HANDLE

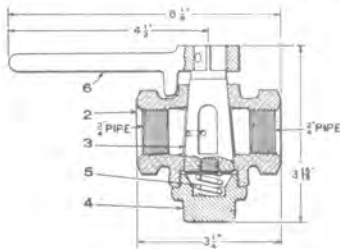

Comp.	Vent Size	Ref. No.					Approx. Net Weight (Lbs.)		
		2		3		4		5	6
		Body	Body With Vent	Key	Key With Vent	Cap		* Spring	Handle Non-Split
54499		2235		2236		94297	2145	42380	2 1/2
91134	1/8"		43076		91651	94297	2145	42380	2 1/2

3/8" CUT-OUT COCKS WITH HANDLE SEALED IN OPEN POSITION

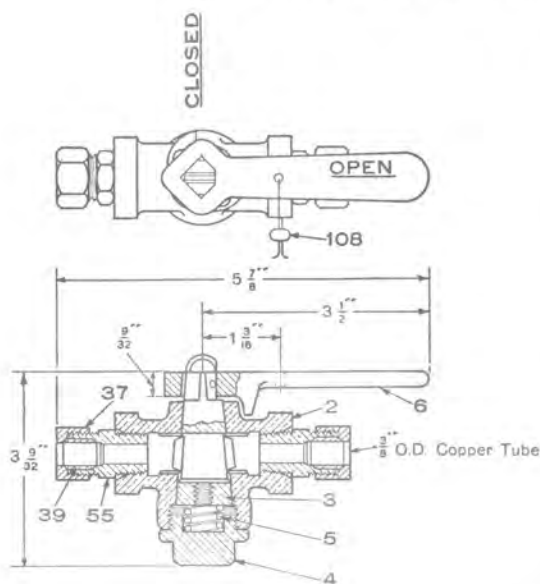

Piece No. 900200 3/8" Cut-out Cock, Complete

Piece No. 901310 3/8" Cut-out Cock, Complete Less Fittings

Pc. No.	Ref. No.	
900193	2	Body
59107	3	Key
59108	4	Cap
*2231	5	Spring
900192	6	Handle
84157		3/8" Compression Union Stud, Complete (2 Req'd) (includes 37, 39 and 55)
71728	37	Nut (2 Req'd)
71727	39	Sleeve (2 Req'd)
80677	55	Stud (2 Req'd)
108		Seal with Wire 12 1/2" long

Approx. Net Weight 1 1/2 Lbs.
Approx. Net Weight, Less Fittings 1 1/4 Lbs.

*NOTE A—For Spring Identification Table, see page 14.
NOTE B—For Packaging, see page 15.

Prices will be quoted upon application
Orders should give PIECE NUMBER and NAME of part wanted

CUT-OUT COCKS

CUT-OUT COCKS WITH HANDLE PARALLEL WITH PIPE WHEN OPEN

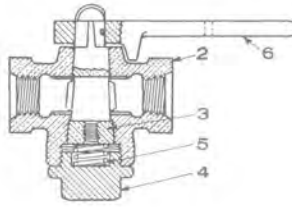

Cock Size	Complete	Vent Size	Ref. No.								Approx. Net Weight (Lbs.)
			2		3		4	5	6		
			Body	Body With Vent	Key	Key With Vent	Cap	* Spring	Handle		
								Split	Non-Split		
3/8"	‡59090	59109	59107	59108	2231	15070	1 1/4
	§504746	1/8"	504744	504745	88064	2231	99224	
	512087	1/8"	512089	512088	59108	2231	15070	
	512302	1/8"	512303	512088	59108	2231	900192	
1/2"	59089	59105	59104	59108	2231	15070	1 1/2
3/4"	59088	59053	59098	27926	2145	18762	2 1/2
1"	33894	5/16"	33895	33891	2140	2098	2103	5 1/2
	‡59369	59375	59141	59143	2098	51041	
1 1/4"	84458	84460	84463	84464	2098	2100	8 1/2

‡Listed for Repairs only, Complete Cocks will not be furnished §Handle not drilled for seal †Vent in Cap

1 1/4" CUT-OUT COCK WITH STRAIGHT LOCK HANDLE

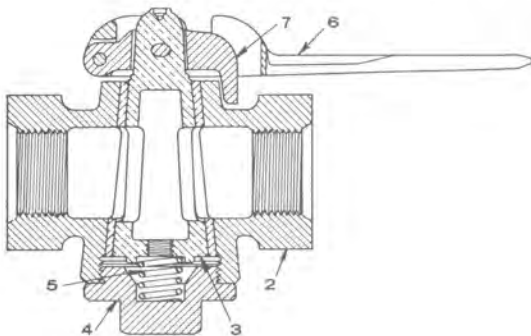

Piece No. 85647 1 1/4" Cut-out Cock, Complete

Pc. No.	Ref. No.	Description
84460	2	Body
84463	3	Key
84464	4	Cap
*2098	5	Spring
37691		Handle, Complete (includes 6 and 7)
37687	6	Handle
37688	7	Handle Socket

Approx. Net Weight 11 lbs.

*NOTE A—For Spring Identification Table, see page 14.
NOTE B—For Packaging, see page 15.

Prices will be quoted upon application
Orders should give PIECE NUMBER and NAME of part wanted

CUT-OUT COCKS

3/8" AND 1" DOUBLE CUT-OUT COCKS

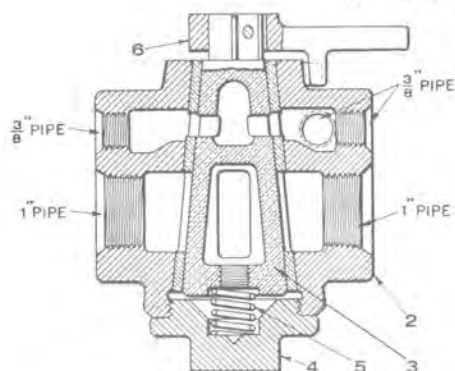

Approx. Net Weight 10 1/4 Lbs.

- Piece No. 11661 3/8" and 1" Double Cut-out Cock, Complete
- Piece No. 530086 3/8" and 1" Double Cut-out Cock, with 1/8" Vent, Complete

Pc. No.	Ref. No.	Description
11662	2	Body, bushed
530087	2	Body, bushed (with 1/8" Vent)
10658	3	Key
530085	3	Key (with 1/8" Vent)
10657	4	Cap
*2098	5	Spring
11667	6	Handle
33711		3/8" Pipe Plug

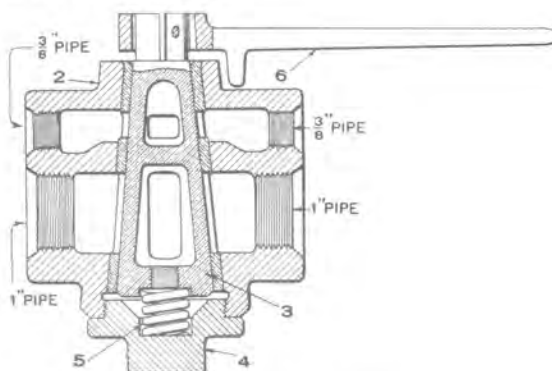

Approx. Net Weight 9 Lbs.

- Piece No. 9517 3/8" and 1" Double Cut-out Cock, Complete
- Piece No. 51018 3/8" and 1" Double Cut-out Cock, with 1/8" Vent, Complete

Pc. No.	Ref. No.	Description
9516	2	Body, bushed
51019	2	Body, bushed (with 1/8" Vent)
9515	3	Key
51017	3	Key (With 1/8" Vent)
2097	4	Cap
*2098	5	Spring
10897	6	Handle

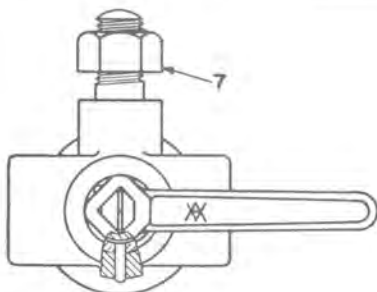

3/8" and 3/8" }
1/2" and 1/2" } DOUBLE CUT-OUT COCKS

- Piece No. 540551 3/8" and 3/8" Double Cut-out Cock, Complete
- Piece No. 84628 1/2" and 1/2" Double Cut-out Cock, Complete
- Piece No. 521641 1/2" and 1/2" Double Cut-out Cock, with 1/16" Vent, Complete

Pc. No.	Ref. No.	Description
540548	2	Body, bushed (for Pc. 540551)
84629	2	Body, complete (includes 7)(for Pc. 84628)
526504	2	Body, complete (includes 7)(for Pc. 521641)
84592	3	Key
521643	3	Key, with 1/16" Vent
84593	4	Cap
*2098	5	Spring
9035	6	Handle (for Pc. 84628 and Pc. 540551)
99224	6	Handle (for Pc. 521641)
17583	7	Stud and Nut (for Pc. 84628 and Pc. 521641)

Approx. Net Weight 5 Lbs.

*NOTE A—For Spring Identification Table, see page 14.
NOTE B—For Packaging, see page 15.

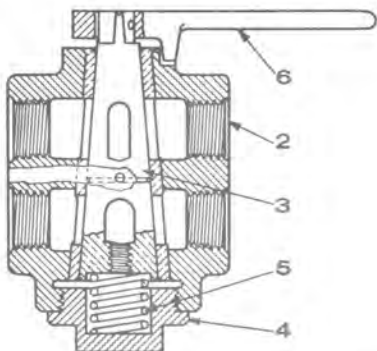

Prices will be quoted upon application
Orders should give PIECE NUMBER and NAME of part wanted

CUT-OUT COCKS

1/2" AND 3/4" DOUBLE CUT-OUT COCKS

Piece No. 528283 1/2" and 3/4" Double Cut-out Cock, Complete

Pc. No.	Ref. No.	
901652	2	Body
528289	3	Key
*900613	4	Spring
75632	5	Cap
75635	6	Handle
6983	22	1"x3/4" Reducing Bushing (2 Req'd)
1635		1/4" Pipe Plug (2 Req'd)

Approx. Net Weight 9 1/2 Lbs.

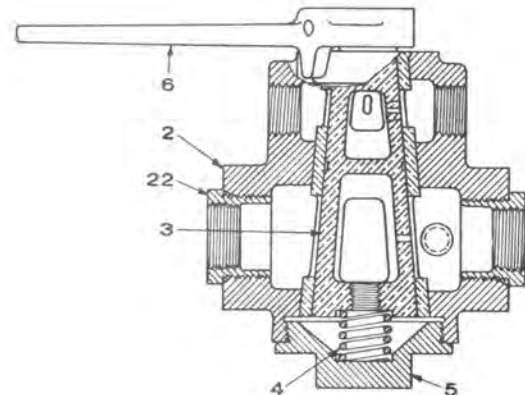
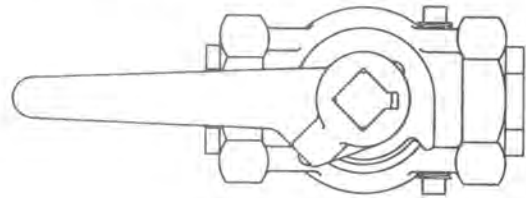

THREE POSITION BRAKE PIPE CUT-OUT COCK

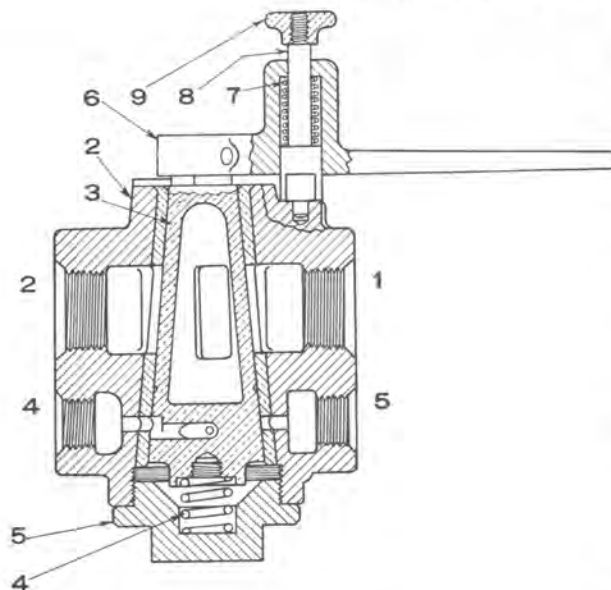

Piece No. 519407 3/8"x1" Three Position Cut-out Cock, Complete

Piece No. 69655 1/2"x1" Three Position Cut-out Cock, Complete

Pc. No.	Ref. No.	
519398	2	Body, for Pc. 519407
70146	2	Body, for Pc. 69655
66805	3	Key
*2098	4	Spring
66806	5	Cap
66807	6	Handle
*66808	7	Handle Spring
66809	8	Handle Pin
69858	9	Handle Pin Nut
33711		3/8" Pipe Plug

Approx. Net Weight 13 7/8 lbs.

*NOTE A—For Spring Identification Table, see page 14.

NOTE B—For Packaging, see page 15.

Prices will be quoted upon application
Orders should give PIECE NUMBER and NAME of part wanted

CUT-OUT COCKS
COCKS WITH "T" HANDLE

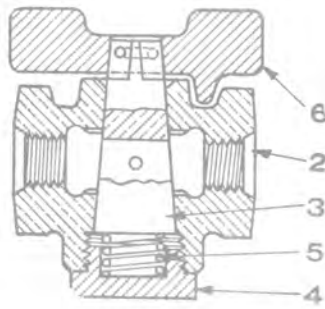

Cock Size	Comp.	Vent Size	Ref. No.						Approx. Net Weight (Lbs.)	
			2		3		4	5		6
			Body	Body With Vent	Key	Key With Vent	Cap	* Spring		Handle
1/4"	520647	1/8"	51311		9056		88064	2231	520654	1 1/4
	520850		84422		512435	88064	2231	520654		
	522499		522500		512435	88064	2231	522501		
3/8"	523369	1/8"		12258		12259	88064	2231	520654	1 1/4
	523370		9055		9056	88064	2231	520654		
1/2"	526382	1/8"	2228		2229		88064	2231	526381	1 1/2
	532944		43078		43079	88064	2231	526381		
3/4"	530793		2235		2236		94297	2145	530792	2 1/2

†Includes seal wire 12 1/2" long

*SPRING IDENTIFICATION

The following table is shown to enable railroad men, storekeepers and all Air Brake men to identify the various springs used in the Cocks cataloged herein. It is based on calculated figures and the actual spring will vary somewhat, due to small differences in wire diameter, coil diameter, number of turns, etc. This tabulation is intended for identification only and should not be used for any other purpose. It does not represent a specification for the springs mentioned.

Pc. No.	Approx. Out. Dia. "A"	Approx. Dia. Wire "B"	Approx. Free Height "C"	† Approx. No. Turns	Material	Name of Spring	Where Used
2098	3/4"	.1055"	1 7/32"	6	Steel	Key Spring	Double and 1 1/4" Cocks
2145	5/8"	.102"	1 43/64"	4 1/2	Brass	Key Spring	3/4" Cut-out Cocks
2231	5/8"	.0907"	1 31/64"	3 1/2	Brass	Key Spring	1/4", 3/8" and 1/2" Cocks
9529	1 1/4"	.162"	2 3/2"	8 1/2	Brass	Key Spring	2" Cut-out Cock
11730	3/8"	.0475"	1 9/16"	13	Steel	Handle Spring	1" and 1 1/4" Cocks with Locking Handle
13109	5/8"	.055"	1 1/16"	9 3/4	Steel	Handle Spring	3/8", 1/2" and 3/4" Cocks with Locking Handle
29615	1 1/8"	.129"	1 31/64"	4	Brass	Key Spring	3/4" Cut-out Cock
66808	1 1/8"	.0475"	1 11/16"	10 1/2	Steel	Handle Spring	Three Position B.P. Cut-out Cock
520304	5/8"	.113"	1 41/64"	3 1/2	Steel	Key Spring	3/4" Cut-out Cock
900613	3/2"	.1285"	1 7/64"	5 3/4	Brass	Key Spring	1/2" x 3/4" Double Cut-out Cock

†Number of turns of wire in each Spring, counted between extreme ends of wire

NOTE A—For Packaging, see page 15.

Prices will be quoted upon application
Orders should give PIECE NUMBER and NAME of part wanted

CUT-OUT COCKS

COCK KEYS

We strongly recommend that all cut-out cocks be returned to us at Wilmerding, Pa., or the Westinghouse Pacific Coast Brake Co., Emeryville, Cal., for repairs, since we have exceptional facilities for handling this work in quantity at low cost, and maintaining standards, so important to Air Brake Apparatus. However, we will furnish, if desired, repair sizes of cut-out cock keys as follows:

1 1/4" CUT-OUT COCK KEYS

Pc. No.	Diameter at Large End
33303	1.608 Minimum
33304	1.6315
2096	1.6555 Standard
33305	1.6815
29543	1.7075 Maximum

1" CUT-OUT COCK KEYS

Pc. No.	Diameter at Large End
34948	1.433 Minimum
2139	1.453 Standard
34949	1.473 Maximum

3/4" CUT-OUT COCK KEYS

34946	1.171 Minimum
2236	1.191 Standard
34947	1.211
89332	1.222 Maximum

1/2" CUT-OUT COCK KEYS

34944	.800 Minimum
2229	.820 Standard
34945	.840 Maximum

1 1/4" CUT-OUT COCK KEYS WITH SPIRAL SIDE VENT

Pc. No.	Diameter at Large End
518440	1.6555 Standard
529764	1.6815
529765	1.7075 Maximum

SHEET METAL THREAD PROTECTORS

Sheet metal thread protectors in the form of caps, plugs and discs are used to close the openings in various devices on shipment from our works, for the purpose of protecting threads from injury and preventing dirt from getting inside the apparatus. These are so satisfactory that we list below the protectors used with various types of cocks, believing that many railroads on account of the small expense involved and the protection insured, will desire to use them when shipping cocks from point to point or when returning old cocks to us for repairs.

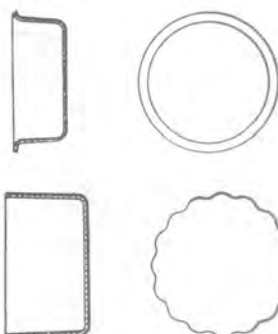

- Piece No. 21228 For 1/4" Pipe Tap
 Piece No. 21194 For 3/8" Pipe Tap
 Piece No. 21195 For 1/2" Pipe Tap
 Piece No. 21196 For 3/4" Pipe Tap
 Piece No. 21197 For 1" Pipe Tap
 Piece No. 21257 For 1 1/4" Pipe Tap

- Piece No. 57386 For 1/2" External Thread
 Piece No. 57387 For 3/4" External Thread

PACKING AND SHIPPING—STANDARD PRACTICE

We strongly recommend that all orders specify material in quantities conforming to our standard practice in boxing and packing. This will not only assist us in filling orders promptly but such original packages should prove of advantage to railroad storekeepers and others through greater convenience and economy in handling, ease of inventory, etc. The Cocks and details cataloged herein are packed as follows:

Description	Pc. No.	No. Per Box	Shpg. Wt. (Lbs.)	Description	Pc. No.	No. Per Box	Shpg. Wt. (Lbs.)	Description	Pc. No.	No. Per Box	Shpg. Wt. (Lbs.)
3/8" Cock	22459	250	360	1" Cock	2135	50	310	Choke Fitting	11644	10	4 1/4
	9053	250	400	1 1/4" Cock	2092	50	490	1" Cock Key	11909	25	26 1/2
	500291	250	400	1 1/4" Cock Key	2096	25	23	Handle Spring	13109	50	1 1/2
1/2" Cock	14493	250	490	Key Spring	2098	125	4 1/2	Choke Fitting	24141	10	8 1/4
	15213	250	425	1" Cock Key	2139	25	17 1/2	Union Swivel	37625	12	2
	99085	250	425	Key Spring	2145	100	2	Union Sleeve	71727	100	1
	501083	250	490	1/2" Cock Key	2229	25	4 1/2	Union Nut	71728	100	4 1/4
3/4" Cock	2233	200	550	Key Spring	2231	200	3	Union Stud	71730	50	3 1/4
	14494	200	620	3/4" Cock Key	2236	25	12	Union Stud Comp.	71713	25	5 3/4
	99081	200	550	3/4" Cock Key	7516	25	11 1/2				
	501074	200	620	1/4", 3/8" Cock Key	9056	25	4 1/2				

NOTE: All other cocks packed as ordered

Prices will be quoted upon application
 Orders should give PIECE NUMBER and NAME of part wanted



Westinghouse Air Brake Company

Wilmerding, Pa., U. S. A.

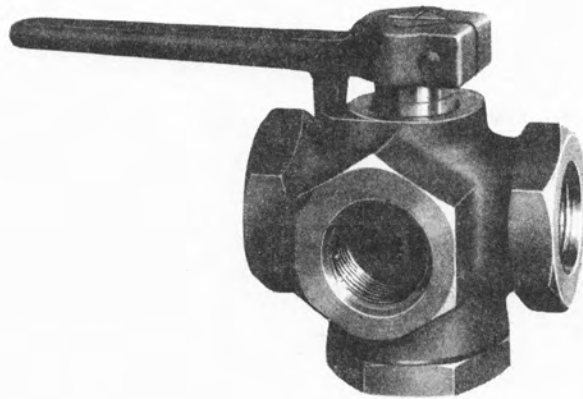

Three Way Cocks

Part Catalog No. 3216-4

Supplement No. 9

March, 1950

(SUPERSEDING PORTION OF JANUARY, 1938 ISSUE OF 3216-4
AND PORTION OF T-3516-4)



THREE-WAY COCKS

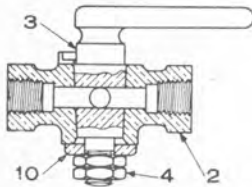
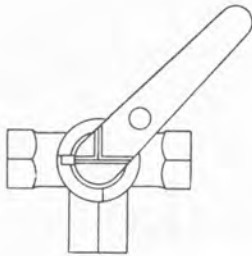

Approx. Net Weight 1 Lb.

Piece No. 524178 1/4" THREE-WAY COCK, Complete

Pc. No.	Ref. No.	Description
18541	2	Body
524179	3	Key With Pin
37159	4	7/16" Hex. Nut (2) Req'd
18573	10	Washer

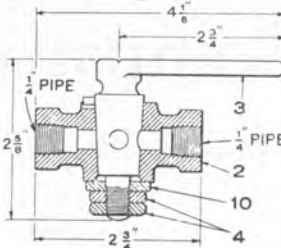
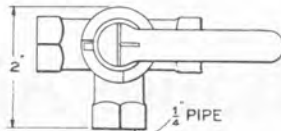

Approx. Net Weight 1 Lb.

Piece No. 18540 1/4" THREE-WAY COCK, Complete

Pc. No.	Ref. No.	Description
18541	2	Body
18542	3	Key
39266	4	7/16" Hex. Nut (2) Req'd
18573	10	Washer

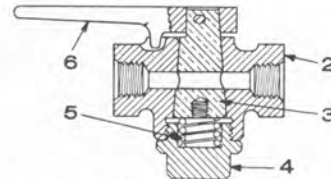
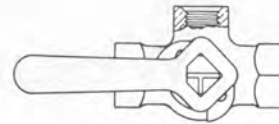

Approx. Net Weight 1 1/4 Lbs.

Piece No. 96934 1/4" THREE-WAY COCK, Complete

Pc. No.	Ref. No.	Description
96933	2	Body
35607	3	Key
35609	4	Cap
*2231	5	Spring
35608	6	Handle

Piece No. 55449 1/4" THREE-WAY COCK, Complete, With Union Connection For 3/8" O.D. Copper Tubing

Pc. No.	Ref. No.	Description
55277	2	Body
35607	3	Key
35609	4	Cap
*2231	5	Spring
35608	6	Handle
21465	7	Swivel
21466	8	Nut

Approx. Net Weight 1 1/4 Lbs.

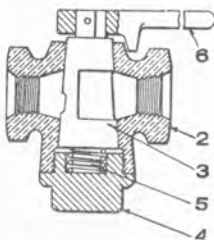
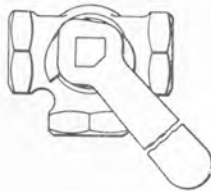
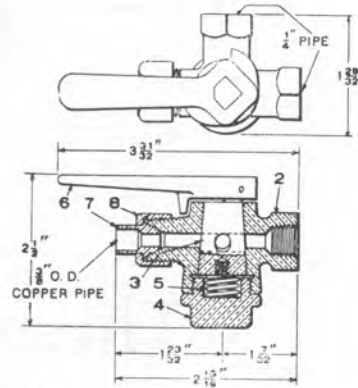

Cock Size	Comp. Pc. No.	Ref. No.					Handle		Approx. Net Weight (Lbs.)
		2	3	4	5	6			
		Body	Key	Cap	* Spring	Split	Non-Split		
1/4"	501544	79932	79933	7875	2231	35608		2	
3/8"	20774	20772	20773	7875	2231	9035		2	
3/8"	501095	20772	20773	7875	2231	99224		2	
3/8"	20775	20772	20773	7875	2231			1 3/4	

*NOTE—For Spring Identification Table, see Page 8.

Prices will be quoted upon application
Orders should give PIECE NUMBER and NAME of part wanted

THREE-WAY COCKS

1/2" THREE-WAY COCKS

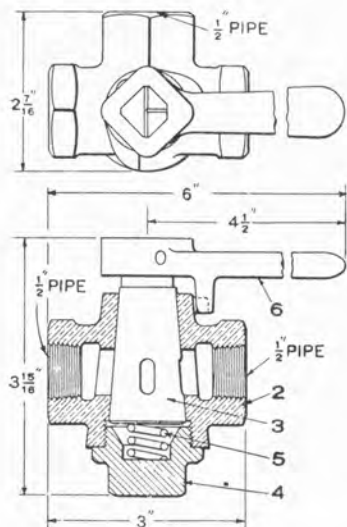

Complete	Ref. No.					
	2	3	4	5	6	
	Body	Key	Cap	* Spring	Handle	
					Split	Non-Split
†9737	9739	9740	94297	2145	15279
31949	9739	31976	94297	2145	15279
§44002	43326	31976	94297	2145	15279
†501056	9739	9740	94297	2145	99210
501072	9739	31976	94297	2145	99210
§501073	43326	31976	94297	2145	99210

§With Untapped Side Connection

†With Extension Key

Approx. Net Weight 2 3/4 Lbs.

Piece No. 501495 1/2" THREE-WAY COCK, Complete

Pc. No.	Ref. No.
501596	2 Body
501597	3 Key
94297	4 Cap
*2145	5 Spring
15279	6 Handle

Approx. Net Weight 3 Lbs.

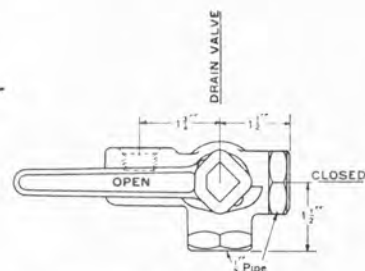

THREE-WAY COCKS WITH HANDLE PARALLEL WITH PIPE WHEN OPEN

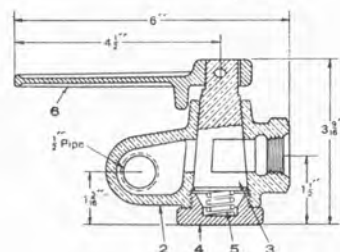
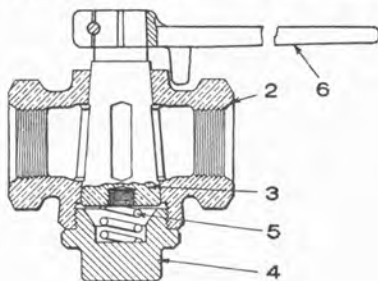

Cock Size	Complete	Ref. No.						Approx. Net Weight (Lbs.)
		2	3	4	5	6		
		Body	Key	Cap	* Spring	Handle		
						Split	Non-Split	
1/2"	516219	9739	516218	94297	2145	99210	2 3/4
3/4"	†10025	10026	10027	94297	2145	10028	3 1/4
	24900	10026	10027	94297	2145	15279	
	501097	10026	10027	94297	2145	99210	

†Stub Handle

NOTE A—These Three-Way Cocks are used primarily as mountain cocks and are located in the cab. The handle position is opposite the standard cut-out cock practice, that is, it is parallel with the pipe when the cock is open.
*NOTE B—For Spring Identification Table, see Page 8.

Prices will be quoted upon application
Orders should give PIECE NUMBER and NAME of part wanted

THREE-WAY COCKS

Piece No. 64589 3/4" THREE-WAY COCK, Complete

Pc. No.	Ref. No.	
10026	2	Body
10027	3	Key
94297	4	Cap
*2145	5	Spring
64590	6	Handle

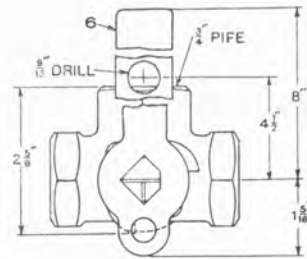

Approx. Net Weight 4 Lbs.

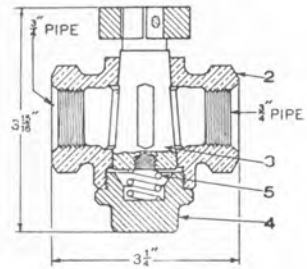

3/4" x 3/4" x 3/8" THREE-WAY COCKS

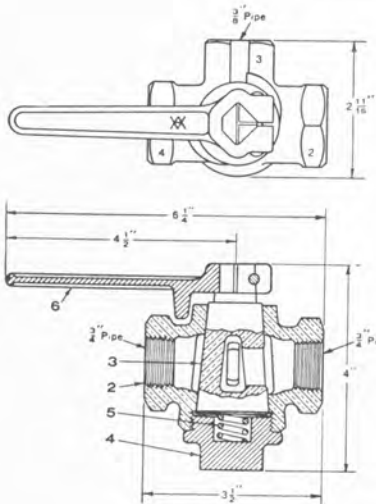

Complete	Ref. No.						Choke Fitting
	2	3	4	5	6		
	Body	Key	Cap	* Spring	Split	Non-Split	
94757	72282	84747	43061	2145			
99086	72282	84747	43061	2145	99199	41451	
519926	72282	84747	43061	2145	99199		11644
519927	72282	84747	43061	2145	99199		519845
†527734	72282	84747	43061	2145	527735		
†540356	72282	84747	43061	2145		540357	

†Short Handle

Approx. Net Weight 3 3/4 Lbs.

- Piece No. 43058 3/4" x 3/4" x 3/8" THREE-WAY COCK WITH 1/4" VENT, Complete, (Non-Split Handle)
- Piece No. 501098 3/4" x 3/4" x 3/8" THREE-WAY COCK WITH 1/4" VENT, Complete, (Split Handle)
- Piece No. 501099 3/4" x 3/4" x 3/8" THREE-WAY COCK WITHOUT VENT, Complete, (Split Handle)

Pc. No.	Ref. No.	
43059	2	Body (With Vent)
72282	2	Body (Without Vent)
43060	3	Key
43061	4	Cap
*2145	5	Spring
41451	6	Handle (Non-Split)
99199	6	Handle (Split)

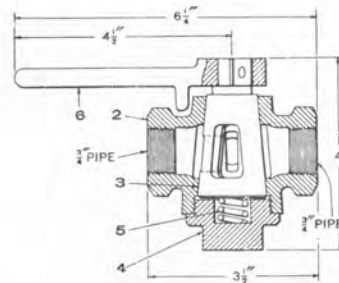

Approx. Net Weight 3 3/4 Lbs.

*NOTE—For Spring Identification Table, see Page 8.

Prices will be quoted upon application
Orders should give PIECE NUMBER and NAME of part wanted

THREE-WAY COCKS

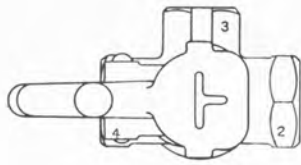

Piece No. 508664 3/4"x3/4"x3/8" THREE-WAY COCK WITH LOCKING HANDLE, Complete

Pc. No.	Ref. No.	Description
72282	2	Body
84747	3	Key
43061	4	Cap
*2145	5	Spring
538404		Handle, Complete (includes 6, 7, 8 and 9)
511101	6	Handle
516494	7	Handle Lock
510928	8	Handle Pin
*13109	9	Handle Spring

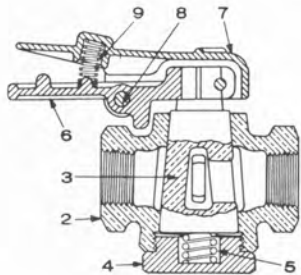

Approx. Net Weight 4 1/4 Lbs.

Piece No. 18537 1" THREE-WAY COCK, Complete
 Piece No. 519957 1"x1"x3/4" THREE-WAY COCK, Complete

Pc. No.	Ref. No.	Description
18538	2	Body
18539	3	Key
2097	4	Cap
*2098	5	Spring
2100	6	Handle
6983		1"x3/4" Reducing Bush (For Pc. 519957)

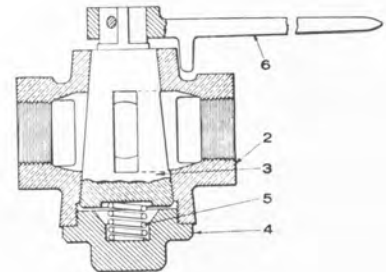
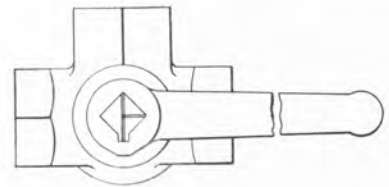

Approx. Net Weight 8 Lbs.

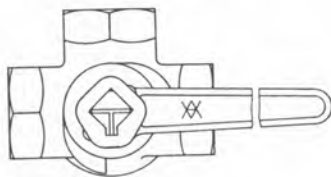

Piece No. 507894 1" THREE-WAY COCK, Complete

Pc. No.	Ref. No.	Description
507667	2	Body
507666	3	Key
2097	4	Cap
*2098	5	Spring
2100	6	Handle

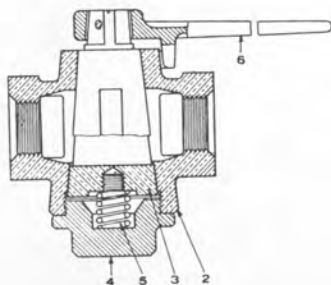

Approx. Net Weight 8 1/4 Lbs.

*NOTE—For Spring Identification Table, see Page 8.

Prices will be quoted upon application
 Orders should give PIECE NUMBER and NAME of part wanted

THREE-WAY COCKS

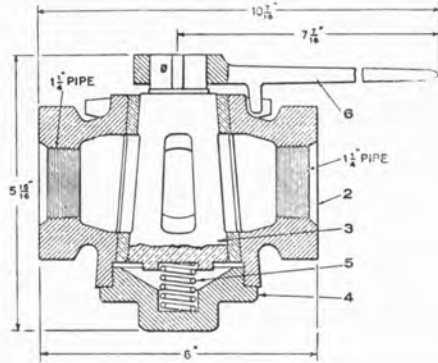

Piece No. 34557 1 1/4" THREE-WAY COCK, Complete

Pc. No.	Ref. No.	
34526	2	Body
48000	3	Key
34556	4	Cap
*34551	5	Spring
34535	6	Handle

Approx. Net Weight 14 Lbs.

THREE-WAY COCKS WITH WABCOTITE FITTINGS
3/4" x 3/4" x 3/8" THREE-WAY COCKS

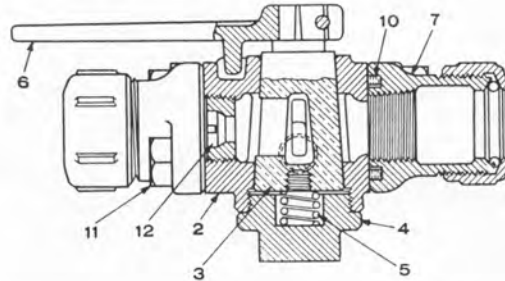

Complete With Fittings	Complete Less Fittings	Pipe Size	Style	Pc. No.	Wabcotite Fitting, Ref. No. 7 See Part Catalog No. 3216-21		Approx. Net Weight (Lbs.)
					Gasket Ref. No. 10	Bolt and Nut Ref. No. 11	
507179	507092	3/4" I.P.	Straight	2 of 93843	93841	25300	7
518104	507092	3/4" I.P.	Straight Elbow	93843 95261	93841	25300	7 3/8
507180	507146	3/4" I.P.	Straight	2 of 93843	93841	25300	7 1/8
518119	518120	3/4" I.P.	Straight	2 of 93843	93841	25300	7 1/8
533315	533514	3/4" I.P.	Straight	2 of 93843	93841	25300	7 1/8

COCKS LESS FITTINGS

Complete Less Fittings	Ref. No.						Approx. Net Weight (Lbs.)
	2	3	4	5	6	12	
	Body	Key	Cap	* Spring	Handle	Choke Plug	
507092	507274	43060	43061	2145	99199	4 1/2
507146	507274	43060	43061	2145	99199	507105 (5/16" Drill)	4 5/8
518120	507274	43060	43061	2145	99199	535000 (1/2" Drill)	4 5/8
533514	507274	43060	43061	2145	99199	535001 (1/2" Drill)	4 5/8

NOTE A—Repairs for Pc. Nos. 519913, 519914, 519916, 519917, 519920, 519921 and 519922 are the same as for Pc. Nos. 507179, 507092, 507180, 507146, 518104, 518119 and 518120 respectively.

*NOTE B—For Spring Identification Table, see Page 8.

Prices will be quoted upon application
Orders should give PIECE NUMBER and NAME of part wanted

**THREE-WAY COCKS
COCKS WITH WABCOTITE FITTINGS**

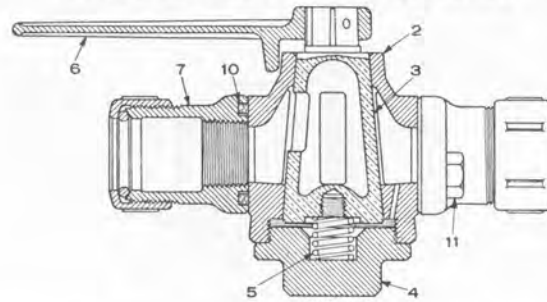

Cock Size	Complete With Fittings	Complete Less Fittings	Wabcotite Fitting Ref. No. 7 See Part Catalog No. 3216-21					Approx. Net Weight (Lbs.)
			Pipe Size	Style	Pc. No.	Gasket Ref. No. 10	Bolt & Nut Ref. No. 11	
						2 Req'd		
3/4" x 3/4" x 3/8"	‡518787	509372	3/4" I.P.	Straight	2 of 97317	93986	25302	10 3/4
3/4" x 3/4" x 3/8"	540074	540073	3/4" I.P.	Straight	2 of 97317	93986	25302	10 3/4
1" x 1" x 3/8"	‡508994	509372	1" I.P.	Straight	2 of 94021	93986	25302	10 3/4
1" x 1" x 3/8"	540069	540073	1" I.P.	Straight	2 of 94021	93986	25302	10 3/4
1" x 1" x 3/8"	‡540081	540082	1" I.P.	Straight	2 of 94021	93986	25302	10 3/4
1" x 1" x 3/4"	540075	540080	1" I.P.	Straight	2 of 94021	93986	25302	10 3/4

COCKS LESS FITTINGS

Cock Size	Complete Less Fittings	Ref. No.					Approx. Net Weight (Lbs.)
		2	3	4	5	6	
		Body Bushed	Key	Cap	Spring	Handle	
1" x 1" x 3/8"	‡509372	509373	509102	509307	2098	537795	6 3/4
1" x 1" x 3/8"	540073	540117	509102	509307	2098	2103	6 3/4
1" x 1" x 3/8"	‡540082	540116	529358	509307	2098	2103	6 3/4
1" x 1" x 3/4"	540080	509371	509102	509307	2098	2103	7

‡Handle opposite as shown in illustration

‡Handle and Side Outlet of Key opposite as shown in illustration

NOTE—Repairs for Pc. Nos. 519949, 519950, 519952, 524301, 524302 and 529359 are the same as for Pc. Nos. 540069, 540073, 540074, 540075, 540080 and 540081 respectively.

**3/4" x 3/4" x 3/8" THREE-WAY COCKS WITH WABCOTITE FITTINGS
AND DOUBLE LOCKING HANDLE**

- Piece No. 526428 3/4" x 3/4" x 3/8" THREE-WAY COCK, Complete (With Wabcotite Sweat Fittings For 7/8" O.D. Tube) (Approx. Net Weight 6 3/4 Lbs.)
- Piece No. 527195 3/4" x 3/4" x 3/8" THREE-WAY COCK, Complete (With Wabcotite Fittings For 3/4" I.P.) (Approx. Net Weight 7 Lbs.)
- Piece No. 527196 3/4" x 3/4" x 3/8" THREE-WAY COCK, Complete Less Wabcotite Fittings (Approx. Net Weight 4 1/2 Lbs.)

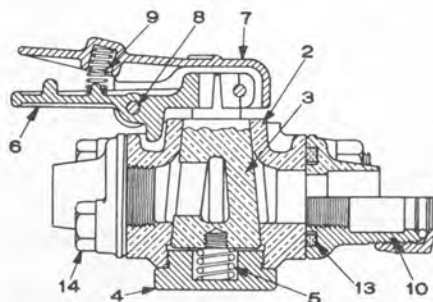

Pc. No.	Ref. No.	Description
507274	2	Body
43060	3	Key
43061	4	Cap
*2145	5	Spring
538405		Handle, Complete (includes 6, 7, 8 and 9)
511101	6	Handle
526449	7	Handle Lock
510928	8	Handle Pin
*13109	9	Handle Spring
502093	10	3/4" Wabcotite Sweat Fitting for 7/8" O.D. Tube (For Pc. 526428) (2 Req'd) See P.C. 3216-21
93843	10	3/4" Wabcotite Fitting, Complete, for 3/4" I.P. (For Pc. 527195) (2 Req'd) See P.C. 3216-21
93841	13	3/4" Wabcotite Fitting Gasket (2 Req'd)
25300	14	1/2" x 4 1/2" Hex. Hd. Bolt and Nut (2 Req'd)

*NOTE—For Spring Identification Table, see Page 8.

Prices will be quoted upon application
Orders should give PIECE NUMBER and NAME of part wanted

THREE-WAY COCKS
COCKS WITH WABCOTITE FITTINGS
AND HANDLE PARALLEL WITH PIPE WHEN OPEN

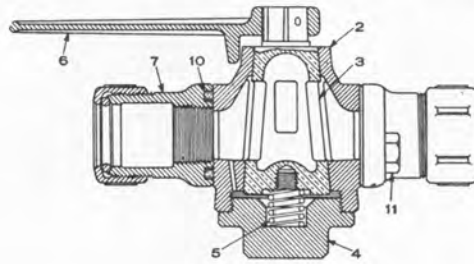

Cock Size	Complete With Fittings	Complete Less Fittings	Wabcotite Fitting Ref. No. 7 See Part Catalog No. 3216-21				Gasket Ref. No. 10	Bolt & Nut Ref. No. 11	Approx. Net Weight (Lbs.)
			Pipe Size	Style	Pc. No.	2 Req'd			
3/4" x 3/4" x 3/8"	‡523706	523790	3/4" I.P.	Straight	2 of 93843	93841	25300	7	
3/4" x 3/4" x 3/4"	519999	520000	3/4" I.P.	Straight	2 of 93843	93841	25334	6 3/4	
3/4" x 3/4" x 3/4"	§518108	509370	3/4" I.P.	Straight	2 of 97317	93986	25302	11	
3/4" x 3/4" x 3/4"	§540118	509370	3/4" I.P.	Straight	97317	93986	25302	11	
				Elbow	507713				
1" x 1" x 3/4"	§509301	509370	1" I.P.	Straight	2 of 94021	93986	25302	11	

COCKS LESS FITTINGS

Cock Size	Complete Less Fittings	Ref. No.						Approx. Net Weight (Lbs.)
		2	3	4	5	6		
		Body	Key	Cap	* Spring	Handle		
						Split	Non-Split	
3/4" x 3/4" x 3/8"	‡523790	507274	43060	43061	2145	523707	4 1/2
3/4" x 3/4" x 3/4"	520000	519992	519993	519994	2145	99199	4 1/4
1" x 1" x 3/4"	§509370	509371	509293	509307	2098	2103	7 1/2

‡Offset Handle, Opposite as shown in illustration

§Body Bushed

NOTE—Repairs for Pc. Nos. 519953, 519954, 519956 and 520743 are the same as for Pc. Nos. 509301, 509370, 518108 and 540118 respectively.

***SPRING IDENTIFICATION**

The following table is shown to enable railroad men, storekeepers and all Air Brake men to identify the various springs used in the Cocks cataloged herein. It is based on calculated figures and the actual spring will vary somewhat, due to small differences in wire diameter, coil diameter, number of turns, etc. This tabulation is intended for identification only and should not be used for any other purpose. It does not represent a specification for the springs mentioned.



SPRING IDENTIFICATION

Pc. No.	Approx. Out. Dia. "A"	Approx. Dia. Wire "B"	Approx. Free Height "C"	†Approx. No. Turns	Material	Name of Spring	Where Used
2098	5/8"	.1055"	1 7/32"	6	Steel	Key Spring	1" Cocks
2145	5/8"	.102"	1 3/4"	4 1/2	Brass	Key Spring	3/4" Cocks
2231	5/8"	.0907"	1 1/2"	3 1/2	Brass	Key Spring	1/4", 3/8" and 1/2" Cocks
13109	23/64"	.055"	1 1/16"	9 3/4	Steel	Handle Spring	3/4" x 3/4" x 3/8" Three-Way Cock
34551	13/16"	.121"	1 7/32"	6	Steel	Key Spring	1 1/4" Three-Way Cock

†Number of turns of wire in each Spring, counted between extreme ends of wire

Prices will be quoted upon application
Orders should give PIECE NUMBER and NAME of part wanted

3216-4
Sup. 10
100-96

Westinghouse Air Brake Company

Wilmerding, Pa., U. S. A.

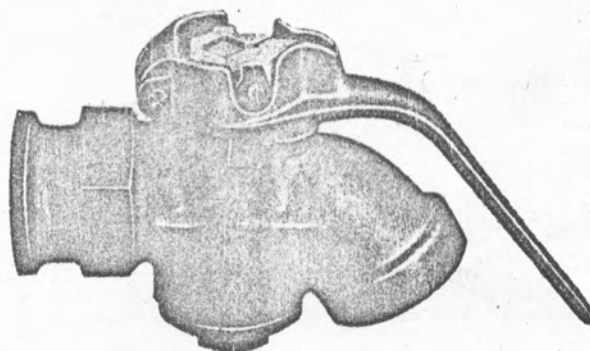

Angle Cocks

Part Catalog No. 3216-4

Supplement No. 10

March, 1950

(SUPERSEDING PORTION OF JANUARY, 1938, ISSUE OF 3216-4
AND PORTION OF T-3516-4)

ANGLE COCKS WITH SUPPORTING FLANGE AND IMPROVED SELF-LOCKING HANDLE

The angle cock with supporting flange and improved (Split-Type) self-locking handle supersedes the former standard, and is standard for freight equipments.

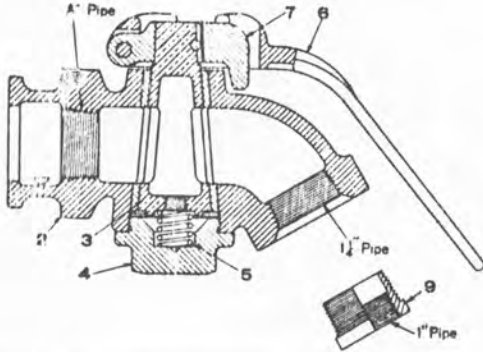

Complete Pc. No.	A
519714	1"
502977	1"
501382	1 1/4"
515955	1 1/4"
517682	1 1/4"
533383	1 1/4"

Approx. Net Weight 11 lbs.

Ref. No.	Name of Part	Pc. No.					
		1"	1"x1 1/4"	1 1/4"			
2	Self-Locking Angle Cock, Complete.....	519714	502977	501382	515955	517682	533383
2	Body, Bushed.....	86808	86808	84312			
2	Body, Bushed, Left Hand.....				515960		
2	Body, Bushed, With Vent.....					517684	
2	Body, Bushed, Left Hand With Vent.....						533382
3	Key.....	501326	501326	501326	501326	517685	535241
4	Cap.....	2097	2097	2097	2097	2097	2097
*5	Spring.....	2098	2098	2098	2098	2098	2098
6	Handle, Complete (includes 6 and 7).....	501381	501381	501381	501381	501381	501381
7	Handle, only.....	501328	501328	501328	501328	501328	501328
9	1 1/4"x1" Bushing.....	501327	501327	501327	501327	501327	501327
		2178					

Repairs for obsolete cocks Pc. Nos. 84311 and 86809 are the same as for cocks Pc. Nos. 501382 and 502977 respectively, except for the Key substitute Pc. No. 2096 and if Handle repair parts are desired a new Handle Complete Pc. No. 501381 should be ordered.

1 1/4" DOUBLE LOCKING ANGLE COCK

The 1 1/4" Double Locking Angle Cock is standard for passenger and locomotive equipments.

Piece No. 502526 1 1/4" Double Locking Angle Cock, Complete

Piece No. 517683 1 1/4" Double Locking Angle Cock, Complete, With Vent

Pc. No.	Ref. No.	Description
84312	2	Body, bushed
517684	2	Body, bushed, With Vent
501326	3	Key
517685	3	Key, With Vent
2097	4	Cap
*2098	5	Key Spring
502527		Handle, Complete (includes 6, 7, 8, 11; two of 9 and 10)
502530	6	Handle
502533	7	Handle Socket
502534	8	Latch
502531	9	Adjusting Screw (2 Req'd)
502532	10	Adjusting Nut (2 Req'd)
*502535	11	Latch Spring

*NOTE—For Spring Identification Table, see Page 3.
NOTE—For Packaging, see Page 4.

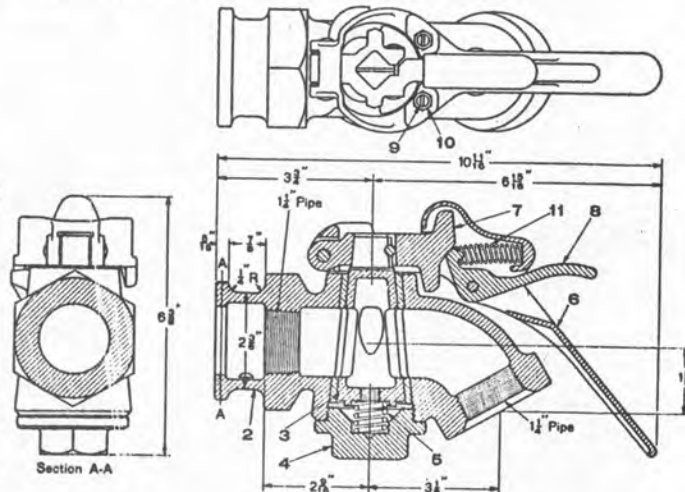

Approx. Net Weight 12 Lbs.

Prices will be quoted upon application

Orders should give PIECE NUMBER and NAME of part wanted

ANGLE COCKS WITHOUT SUPPORTING FLANGE

Self-locking angle cocks without supporting flange and improved (Split-Type) self-locking handle.

- Piece No. 523505 1" Self-locking Angle Cock, Complete (Approx. Net Weight 7 Lbs.)
- Piece No. 523506 1" Self-locking Angle Cock, Complete With Choke (Approx. Net Weight 7 3/4 Lbs.)
- Piece No. 536935 3/4"x1" Self-locking Angle Cock, Complete (Approx. Net Weight 7 1/4 Lbs.)

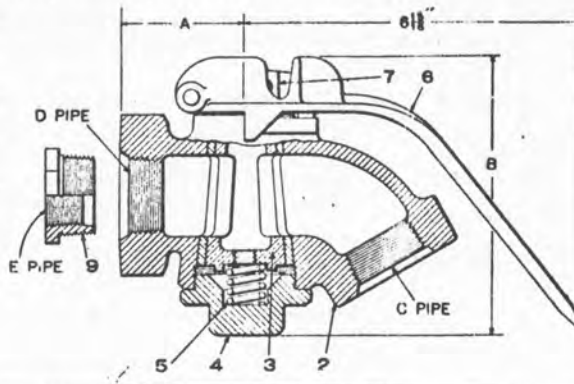

Pc. No.	Ref. No.	Description
14866	2	Body, Bushed
14864	3	Key
2140	4	Cap
*2098	5	Spring
501381		Handle, Complete (includes 6 and 7)
501328	6	Handle, only
501327	7	Handle Socket
24141	9	1" Bushing with 1/8" Choke (For Pc. 523506)
6983	9	1"x3/4" Bushing (For Pc. 536935)

Cock Size	A	B	C	D	E
3/4"x1"	2 7/8"	4 1/2"	1"	1"	3/4"
1"	2 7/8"	4 1/2"	1"	1"	3/4"

The following self-locking angle cocks, complete, are obsolete and will not be furnished. Only detail repair parts as shown in schedule will be furnished. If handle repair parts are desired a new handle complete Pc. No. 501381 should be ordered.

Ref. No.	Name of Part	1"x1 1/4"	1 1/4"	1"	3/4"x1"
	Self-locking Angle Cock, Complete..	22412	22413	22416	58222
2	Body, Bushed.....			14866	14866
3	Key.....	2096	2096	14864	14864
4	Cap.....	2097	2097	2140	2140
*5	Spring.....	2098	2098	2098	2098
9	Bushing.....		2178		6983

Self-locking angle cock without supporting flange and with former standard handle (Non-Split Type).

- Piece No. 18309 3/4" Self-locking Angle Cock, Complete

Pc. No.	Ref. No.	Description
14910	2	Body, Bushed
2236	3	Key
14897	4	Cap
*2145	5	Spring
17833		Handle, Complete (includes 6 and 7)
17832	6	Handle, only
17831	7	Handle Socket

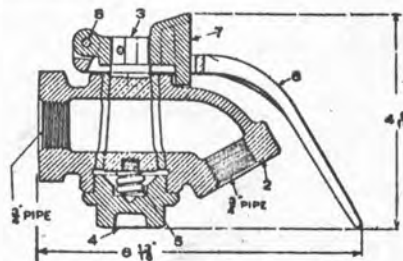

Approx. Net Weight 4 3/4 Lbs.

***SPRING IDENTIFICATION**

The following table is shown to enable railroad men, storekeepers and all Air Brake men to identify the various springs used in the Cocks cataloged herein. It is based on calculated figures and the actual spring will vary somewhat, due to small differences in wire diameter, coil diameter, number of turns, etc. This tabulation is intended for identification only and should not be used for any other purpose. It does not represent a specification for the springs mentioned.

Pc. No.	Approx. Outside Dia. "A"	Approx. Dia. Wire "B"	Approx. Free Height "C"	†Approx. No. Turns	Material	Name of Spring	Where Used
2098	3/4"	1055"	1 7/8"	6	Steel	Key Spring	1 1/2" Angle Cock
2145	5/8"	102"	1 1/2"	4 1/2	Brass	Key Spring	3/4" Angle Cock
502535	1 1/2"	0625"	1 3/4"	15	Steel	Latch Spring	1 1/4" Double Locking Angle Cock

†Number of turns of wire in each spring, counted between extreme ends of wire.

NOTE—For Packaging, see Page 4.

Prices will be quoted upon application
Orders should give **PIECE NUMBER** and **NAME** of part wanted

COCK KEYS

We strongly recommend that all angle cocks be returned to us at Wilmerding, Pa., or the Westinghouse Pacific Coast Brake Co., Emeryville, Cal., for repairs, since we have exceptional facilities for handling this work in quantity at low cost, and maintaining standards so important to Air Brake Apparatus. However, we will furnish, if desired, repair sizes of angle cock keys as follows:

1 1/4" ANGLE COCK KEYS		3/4" ANGLE COCK KEYS		1 1/4" SELF-LOCKING ANGLE COCK KEYS			
Pc. No.	Diameter at Large End	Pc. No.	Diameter at Large End	Pc. No.	Pc. No.	Pc. No.	Diameter at Large End
33303	1.608" Minimum	34946	1.171" Minimum	501326	517685	535241	1.6555" Standard
33304	1.6315"	2236	1.191" Standard	516234	529766	535242	1.6815"
2096	1.6555" Standard	34947	1.211"	516235	529767	535243	1.7075" Maximum
33305	1.6815"	89332	1.222" Maximum				
29543	1.7075" Maximum						

PACKING AND SHIPPING--STANDARD PRACTICE

We strongly recommend that all orders specify material in quantities conforming to our standard practice in boxing and packing. This will not only assist us in filling orders promptly but such original packages should prove of advantage to railroad storekeepers and others through greater convenience and economy in handling, ease of inventory, etc. The Cocks and Details cataloged herein are packed as follows:

Description	Pc. No.	No. Per Box	Shipping Weight (Lbs.)	Description	Pc. No.	No. Per Box	Shipping Weight (Lbs.)
3/4" Cock	18309	*	*	3/4"x1" Cock	536935	*	*
1 1/4" Cock	501382	25	300	1 1/4" Cock	533383	*	*
1 1/4" Cock	502526	25	300	1 1/4" Handle, Comp.	501381	100	180
1"x1 1/4" Cock	502977	*	*	1 1/4" Key	2096	25	23
1 1/4" Cock	515955	*	*	1 1/4" Spring	2098	125	4 1/2
1 1/4" Cock	517682	*	*	3/4" Spring	2145	100	2
1 1/4" Cock	517683	*	*	3/4" Key	2236	25	12
1" Cock	519714	*	*	1 1/2" Bushing	24141	10	8 1/4
1" Cock	523505	*	*	1" and 1 1/4" Key	501326	25	23
1" Cock	523506	*	*	1 1/4" Key	517685	25	23
				1 1/4" Key	535241	25	23

*NOTE--Packed as ordered.

Prices will be quoted upon application

Orders should give PIECE NUMBER and NAME of part wanted



OFFICES

ATLANTA 3,	Candler Building
BOSTON 16,	Statler Building
CHICAGO 4,	Railway Exchange Building
CLEVELAND 15,	Midland Building
DENVER 2,	Denver National Building
HOUSTON, 2, TEX.	Commerce Building
LOS ANGELES 14,	Pacific Electric Building
MEXICO, D. F., MEXICO	Edificio Aztlan
NEW YORK 1,	Empire State Building
ST. LOUIS 3,	Shell Building
ST. PAUL 1,	First National Bank Building
SAN FRANCISCO 5,	Matson Building
SEATTLE 1,	Securities Building
WASHINGTON, 6, D.C.	Ring Building



Westinghouse Air Brake Company

Wilmerding, Pa., U. S. A.

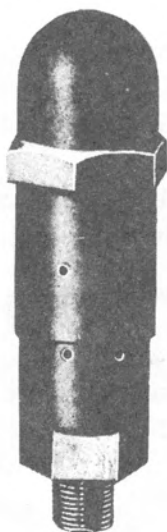

Safety Valves

Part Catalog No. 3216-6

January, 1949

(SUPERSEDING ISSUE OF JULY, 1944)



TYPE A SAFETY VALVE

(55 lbs. to 80 lbs.)

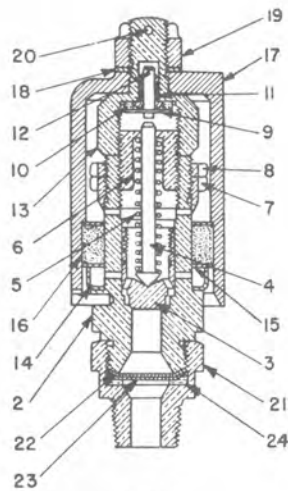

Fig. 1

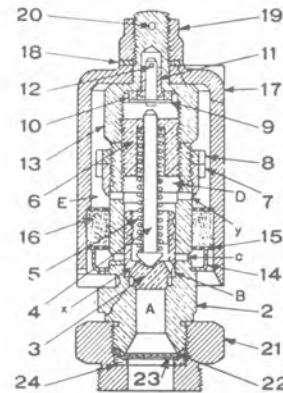

Fig. 2

Approx. Net Weight 1¼ lbs.

Piece No. 512295 Type A Safety Valve, complete (Stencilled "Pass.") for D-22 and D-24 Control Valves (See Fig. 1)

Piece No. 522363 Type A Safety Valve, complete (Stencilled "Fr't.") for AB-1-B Valve (See Fig. 1)

Piece No. 531994 Type A Safety Valve, complete (Stencilled "D.V.") for Distributing Valves (See Fig. 2)

Pc. No.	Ref. No.	Pc. No.	Ref. No.
511224	2	513244	14
513245	3	513243	15
513250	4		
*511225	5	513242	16
511226	6	513249	17
511227	7	513238	18
511228	8	513237	19
532200	Spring Guide Stop, Complete (includes 9, 10, 11 and 12)	93258	20
513240	9	518582	21
83993	10	530217	21
513239	11		
513248	12	518585	22
513241	13	518584	23
		95611	24

*NOTE—For Spring Identification Table, see page 7.

Prices will be quoted upon application

Orders should give PIECE NUMBER and NAME of part wanted

E-7-B SAFETY VALVES

The E-7-B Safety Valve is used in the Main Reservoir System and is a part of fundamental Locomotive Brake Equipments.

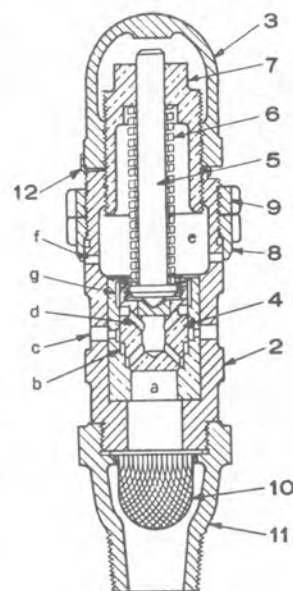

Approx. Net Weight
4 lbs.

Pressure Range	COMPLETE PIECE NUMBERS					
	15-25 lbs.	20-40 lbs.	35-70 lbs.	60-95 lbs.	85-150 lbs.	140-175 lbs.
Safety Valve, Complete (Adapter for 1" Pipe) . . .	529818	529819	530996	529820	536995	536852
Safety Valve, Complete (Adapter for 1 1/4" Pipe) . .					536996	536955
Safety Valve, Complete, less Strainer & Adapter. .	529841	529842	530997	529843	536999	536870

Pc. No.	Ref. No.	†No. per Pkg.		Pc. No.	Ref. No.	†No. per Pkg.	
537852	2		Safety Valve Body	*536683	6		Spring (140 to 175 lbs.)
9029	3		Cap Nut	16087	7	10	Regulating Nut
537404	4		Valve	12797	8	10	Exhaust Regulating Ring
536854	5		Valve Stem	12798	9	16	Lock Ring
*1057	6		Spring (15 to 25 lbs.)	1751	10	100	Strainer
*18286	6	100	Spring (20 to 40 lbs.)	516313	11		Adapter for 1" Pipe
*1523	6		Spring (30 to 70 lbs.)	516955	11		Adapter for 1 1/4" Pipe
*18414	6	12	Spring (60 to 95 lbs.)	537911	12		Cap Nut Lock Washer
*83997	6		Spring (85 to 150 lbs.)				

*NOTE A—For Spring Identification Table, see page 7.

†NOTE B—Column headed "No. per Pkg." indicates the items for which standard shipping packages have been established and the number contained in the package. Orders placed in these quantities and multiples thereof will facilitate shipments and provide convenient means for handling in storeroom stock.

NOTE C—Safety Valves of Pc. Nos. 516182, 527441 and 516977, formerly furnished for pressures from 85 to 170 pounds, are now superseded by the Safety Valves listed above under the two headings, "85-150" and "140-175" lbs. Repair parts for the former standard valves should be ordered from the above list, according to the Pressure Ranges shown.

NOTE D—When it is desired to mount E-7-B Safety Valve on Main Reservoir arranged for use with Wabcoite Flanged Fittings, we are prepared to furnish Main Reservoir Safety Valve Mounting Piece.

Prices will be quoted upon application

Orders should give PIECE NUMBER and NAME of part wanted

E-7 SAFETY VALVE

This Safety Valve is a special valve not used for general purposes. It is a part of and is regularly supplied with Type L Triple Valves and Steam Road Universal Valves; it was formerly supplied with No. 8-A Distributing Valve, but is now replaced by the Type "A" for that service.

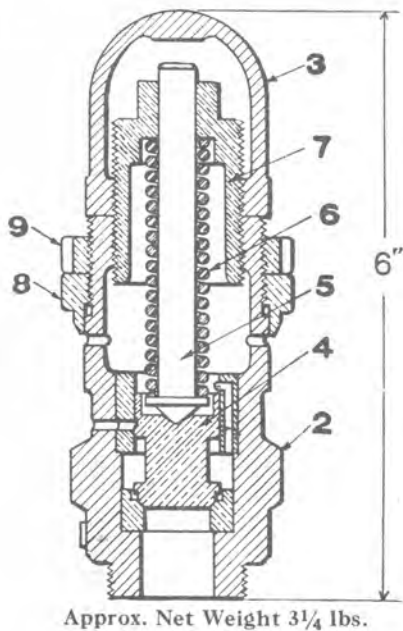

- Piece No. 15549 E-7 Safety Valve (50 to 90 lbs.) complete**
- Piece No. 71753 E-7 Safety Valve (80 to 130 lbs.)**
- Piece No. 71776 E-7 Safety Valve (110 to 150 lbs.)**

Piece No.	Ref. No.	No. Per Pkg.	Description
15538	2	6	Body, bushed
9029	3		Cap Nut
10524	4	24	Valve
10523	5	24	Valve Stem
*24113	6	20	Spring (50 lbs. to 90 lbs.)
*24112	6	25	Spring (80 lbs. to 130 lbs.)
*13434	6	12	Spring (110 lbs. to 150 lbs.)
16087	7	10	Regulating Nut
12797	8	10	Exhaust Regulating Ring
12798	9	16	Lock Ring

E-7-A SAFETY VALVE

The E-7-A Safety Valve has been superseded by the E-7-B type and the Complete Piece Numbers tabulated below are for identification purposes only. If a Body or E-7-A Safety Valve require replacement, a new E-7-B Safety Valve should be ordered from the schedule on page 3. The detail parts listed below are maintained for repairs of the E-7-A Safety Valve.

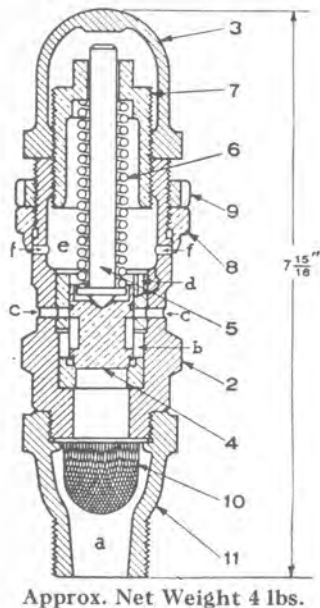

Pressure Range	COMPLETE PIECE NUMBERS		
	50-90 lbs.	80-130 lbs.	110-150 lbs.
Safety Valve, Complete (Adapter for 1" Pipe)	515385	518337	513901
Safety Valve, Complete (Adapter for 1 1/4" Pipe)	518470	518339	516217
Safety Valve, Complete, less Strainer & Adapter	518336	518338	513902

Pc. No.	Ref. No.	No. Per Pkg.	Description
9029	3		Cap Nut
10524	4	24	Valve
10523	5	24	Valve Stem
*24113	6	20	Spring (50 lbs. to 90 lbs.)
*24112	6	25	Spring (80 lbs. to 130 lbs.)
*13434	6	12	Spring (110 lbs. to 150 lbs.)
16087	7	10	Regulating Nut
12797	8	10	Exhaust Regulating Ring
12798	9	16	Lock Ring
1751	10	100	Strainer
513889	11		1" Pipe Adapter
516213	11		1 1/4" Pipe Adapter

*NOTE A—For Spring Identification Table, see page 7.

†NOTE B—Column headed "No. Per Pkg." indicates the items for which standard shipping packages have been established and the number contained in the package. Orders placed in these quantities and multiples thereof will facilitate shipments and provide convenient means for handling in store room stock.

Prices will be quoted upon application

Orders should give **PIECE NUMBER** and **NAME** of part wanted

E-1 SAFETY VALVES

This Safety Valve is suitable for general service where a high-grade air pressure safety valve is required. When necessary to have a close or adjustable range between the opening and closing points, the Type E-3 Safety Valve should be used.

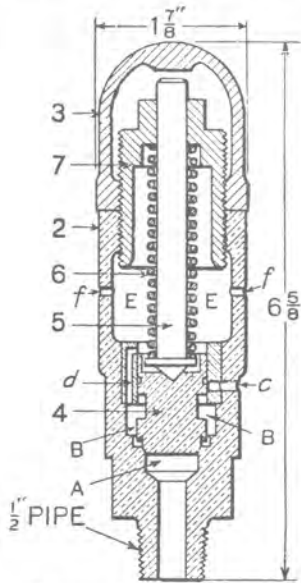

Approx. Net Weight 3 lbs.

- Piece No. 28487 E-1 Safety Valve (5 lbs. to 25 lbs.) complete
- Piece No. 18598 E-1 Safety Valve (10 lbs. to 40 lbs.) complete
- Piece No. 10526 E-1 Safety Valve (35 lbs. to 75 lbs.) complete
- Piece No. 24106 E-1 Safety Valve (60 lbs. to 100 lbs.) complete
- Piece No. 24107 E-1 Safety Valve (80 lbs. to 130 lbs.) complete
- Piece No. 24108 E-1 Safety Valve (110 lbs. to 150 lbs.) complete

Piece No.	Ref. No.	†No. Per Pkg.	
10528	2	6	Body, bushed
9029	3		Cap Nut
10524	4	24	Valve
10523	5	24	Valve Stem
*18286	6	100	Spring (5 lbs. to 25 lbs.)
*18414	6	12	Spring (10 lbs. to 40 lbs.)
* 1498	6	12	Spring (35 lbs. to 75 lbs.)
* 3639	6	12	Spring (60 lbs. to 100 lbs.)
*24112	6	25	Spring (80 lbs. to 130 lbs.)
*13434	6	12	Spring (110 lbs. to 150 lbs.)
9030	7	10	Regulating Nut

E-3 SAFETY VALVES

This Safety Valve is provided with an adjustable Exhaust Regulating Ring, by means of which the "drop" or range between the opening and closing points of the safety valve can be adjusted to any desired amount. It is, therefore, particularly adapted for use where it is desirable to keep this range at any given amount, large or small.

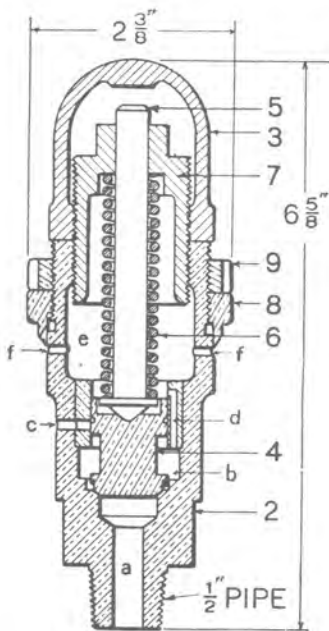

Approx. Net Weight 3 1/2 lbs.

- Piece No. 89006 E-3 Safety Valve (10 lbs. to 40 lbs.) complete
- Piece No. 24109 E-3 Safety Valve (50 lbs. to 90 lbs.) complete
- Piece No. 24110 E-3 Safety Valve (80 lbs. to 130 lbs.) complete
- Piece No. 12705 E-3 Safety Valve (110 lbs. to 150 lbs.) complete
- Piece No. 24111 E-3 Safety Valve (140 lbs. to 225 lbs.) complete
- Piece No. 15494 E-3 Safety Valve (210 lbs. to 325 lbs.) complete
- Piece No. 26079 E-3 Safety Valve (300 lbs. to 400 lbs.) complete

Piece No.	Ref. No.	†No. Per Pkg.	
12795	2	6	Body, bushed
9029	3		Cap Nut
10524	4	24	Valve
10523	5	24	Valve Stem
*18414	6	12	Spring (10 lbs. to 40 lbs.)
*24113	6	20	Spring (50 lbs. to 90 lbs.)
*24112	6	25	Spring (80 lbs. to 130 lbs.)
*13434	6	12	Spring (110 lbs. to 150 lbs.)
*24114	6	12	Spring (140 lbs. to 225 lbs.)
*12490	6		Spring (210 lbs. to 325 lbs.)
*26078	6		Spring (300 lbs. to 400 lbs.)
9030	7	10	Regulating Nut
12797	8	10	Exhaust Regulating Ring
12798	9	16	Lock Ring

*NOTE A—For Spring Identification Table, see page 7.

†NOTE B—Column headed "No. Per Pkg." indicates the items for which standard shipping packages have been established and the number contained in the package. Orders placed in these quantities and multiples thereof will facilitate shipments and provide convenient means for handling in store room stock.

Prices will be quoted upon application

Orders should give PIECE NUMBER and NAME of part wanted

TYPE E-6 SAFETY VALVE

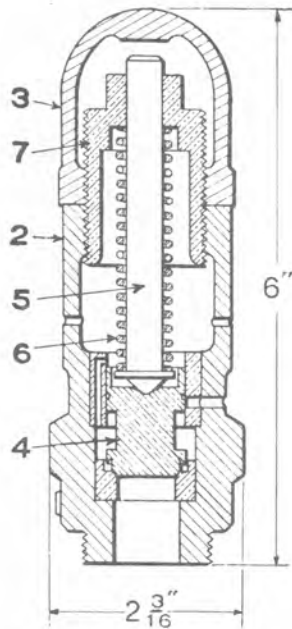

Approx. Net Weight 3 lbs.

This Safety Valve is a special valve, not used for general purposes. It was formerly part of and regularly supplied with the No. 6 and No. 14 Distributing Valves, but is now replaced by the type "A" for that service.

**Piece No. 15890 E-6 Safety Valve (50 to 90 lbs.)
complete**

Piece No.	Ref. No.	†No. Per Pkg.	
15554	2	6	Body, bushed
9029	3		Cap Nut
10524	4	24	Valve
10523	5	24	Valve Stem
*24113	6	20	Spring (50 lbs. to 90 lbs.)
16087	7	10	Regulating Nut

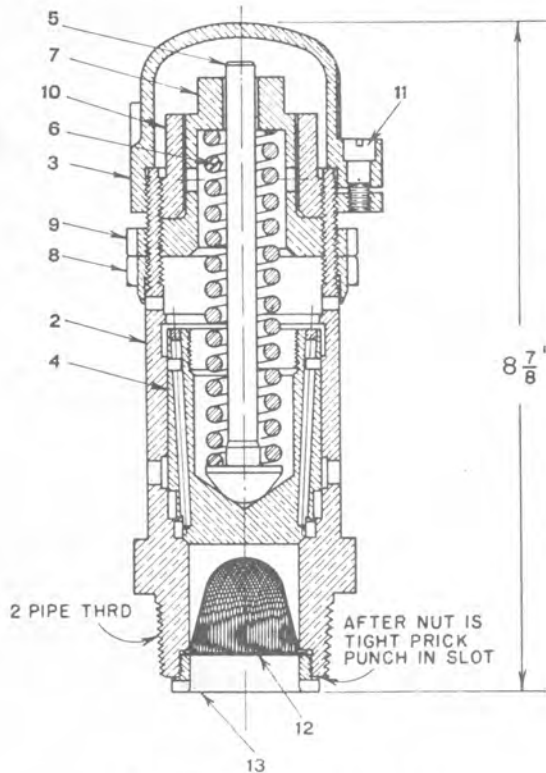

Approx. Net Weight 10½ lbs.

SAFETY VALVE FOR 2" PIPE

**Piece No. 515561 Safety Valve for 2" Pipe, complete,
800 Cu. Ft. Capacity—150 lbs.
Pressure**

Pc. No.	Ref. No.	
515911	2	Body
515912	3	Cap Nut
515913	4	Valve
515914	5	Valve Stem
*4486	6	Spring
515915	7	Regulating Nut
515916	8	Exhaust Regulating Nut
515917	9	Exhaust Regulating Lock Nut
515918	10	Regulating Nut Lock Nut
515919	11	Fil. Hd. Cap Screw
515920	12	Strainer
515921	13	Strainer Retaining Ring

*NOTE A—For Spring Identification Table, see page 7.

†NOTE B—Column headed "No. Per Pkg." indicates the items for which standard shipping packages have been established and the number contained in the package. Orders placed in these quantities and multiples thereof will facilitate shipments and provide convenient means for handling in store room stock.

Prices will be quoted upon application

Orders should give **PIECE NUMBER** and **NAME** of part wanted

SAFETY VALVES

SPRING IDENTIFICATION

The following table is shown to enable railroad men, storekeepers and all Air Brake men to identify the various springs used in the Safety Valves cataloged herein. It is based on calculated figures and the actual spring will vary somewhat, due to small difference in wire diameter, coil diameter, number of turns, etc. This tabulation is intended for identification only and should not be used for any other purpose. It does not represent a specification for the springs mentioned.

		SPRING IDENTIFICATION				
Pc. No.	Out. Dia. "A"	Dia. Wire "B"	Free Height "C"	*Approx. No. Coils	Material	Where Used
1057	$\frac{9}{16}$ "	.058"	$2\frac{3}{4}$ "	15 $\frac{1}{2}$	Cadmium Plated	E-7-B, 15 lbs. to 25 lbs.
1498	$\frac{5}{8}$ "	.092"	$3\frac{1}{4}$ "	20	Cadmium Plated	E-1, 35 lbs. to 75 lbs.
1523	$\frac{19}{32}$ "	.080"	$2\frac{1}{8}$ "	16	Cadmium Plated	E-7-B, 30 lbs. to 70 lbs.
3639	$\frac{3}{4}$ "	.106"	$3\frac{3}{8}$ "	16	Cadmium Plated	E-1, 60 lbs. to 100 lbs.
4486	1"	.220"	$5\frac{1}{4}$ "	17 $\frac{1}{2}$	Cadmium Plated	Safety Valve for 2" Pipe
12490	$\frac{23}{32}$ "	.148"	$3\frac{3}{4}$ "	16 $\frac{1}{2}$	Cadmium Plated	E-3, 210 lbs. to 325 lbs.
13434	$\frac{11}{16}$ "	.121"	$3\frac{5}{8}$ "	17	Cadmium Plated	E-1, E-3 and E-7, 110 lbs. to 150 lbs.
18286	$\frac{13}{16}$ "	.072"	$2\frac{3}{4}$ "	15	Cadmium Plated	E-1, 5 lbs. to 25 lbs.; E-7-B, 20 to 40 lbs.
18414	$\frac{11}{16}$ "	.080"	$2\frac{1}{8}$ "	15	Cadmium Plated	E-1 and E-3, 10 lbs. to 40 lbs.
24112	$\frac{11}{16}$ "	.121"	$3\frac{3}{8}$ "	17	Cadmium Plated	E-1, E-3 and E-7, 80 lbs. to 130 lbs.
24113	$\frac{11}{16}$ "	.106"	$2\frac{3}{4}$ "	15 $\frac{1}{2}$	Cadmium Plated	E-3, E-6 and E-7, 50 lbs. to 90 lbs.
24114	$\frac{23}{32}$ "	.135"	$3\frac{1}{4}$ "	15	Cadmium Plated	E-3, 140 lbs. to 225 lbs.
26078	$\frac{3}{4}$ "	.162"	$3\frac{7}{8}$ "	13 $\frac{1}{2}$	Cadmium Plated	E-3, 300 lbs. to 400 lbs.
83997	$\frac{11}{16}$ "	.107"	$3\frac{5}{8}$ "	17	Cadmium Plated	E-7-B, 85 lbs. to 150 lbs.
511225	$\frac{11}{16}$ "	.054"	2"	19 $\frac{1}{2}$	Cadmium Plated	Type A Safety Valve
536683	$\frac{3}{4}$ "	.120"	$3\frac{1}{4}$ "	15	Stainless Steel	E-7-B, 140 lbs. to 175 lbs.

NOTE—Number of turns in each spring counted between extreme ends of the wire.

PACKING AND SHIPPING—STANDARD PRACTICE

Safety Valves are packed as required, either separately or with other material.

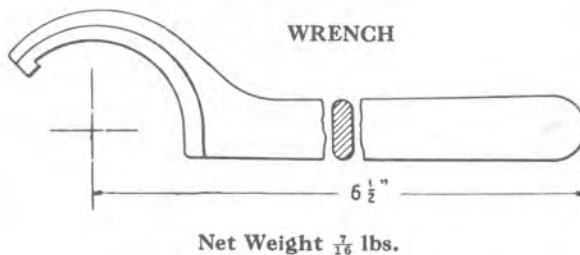

Piece No. 22605 Wrench for E-3, E-7, E-7-A and E-7-B Safety Valve Regulating Rings

Prices will be quoted upon application
Orders should give PIECE NUMBER and NAME of part wanted

Westinghouse Air Brake Company

Wilmerding, Pa., U. S. A.

OFFICES

ATLANTA 3,	- - - - -	Candler Building
BOSTON 16,	- - - - -	Statler Building
CHICAGO 4,	- - - - -	Railway Exchange Building
CLEVELAND 15,	- - - - -	Midland Building
DENVER 2,	- - - - -	Denver National Building
HOUSTON, 2, TEX.	- - - - -	Commerce Building
LOS ANGELES 14,	- - - - -	Pacific Electric Building
MEXICO, D. F., MEXICO	- - - - -	Edificio Aztlan
NEW YORK 1,	- - - - -	Empire State Building
ST. LOUIS 3,	- - - - -	Shell Building
ST. PAUL 1,	- - - - -	First National Bank Building
SAN FRANCISCO 5,	- - - - -	Matson Building
SEATTLE 1,	- - - - -	Securities Building
WASHINGTON, 6, D.C.	- - - - -	Ring Building



ASSOCIATED COMPANIES

WESTINGHOUSE PACIFIC COAST BRAKE
COMPANY
Emeryville, Calif.

WESTINGHOUSE BRAKE & SIGNAL
COMPANY, LTD.
Chippenham, Wilts., England

COMPAGNIA ITALIANA WESTINGHOUSE
FRENI & SEGNALI
Turin, Italy

CANADIAN WESTINGHOUSE COMPANY, LTD.
Hamilton, Ontario, Canada

COMPAGNIE DES FREINS & SIGNAUX
WESTINGHOUSE
Paris, France

WESTINGHOUSE BRAKE (AUSTRALASIA)
PROPRIETARY, LTD.

Concord West, New South Wales, Australia
WESTINGHOUSE BREMSSEN GESELLSCHAFT, m.b.H
Hanover, Germany

Westinghouse Air Brake
Company
Air Brake Division
Wilmerding, Pa., U. S. A.



$\frac{1}{2}$ " Check Valve

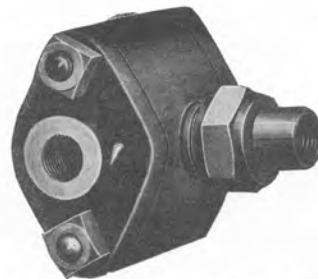

No. 15 Double Check Valve



C-1 Strainer and Check Valve

Check Valves
 Including
Filler Block with Double Check Valve

Part Catalog No. 3216-24

October, 1947

(SUPERSEDING CHECK VALVE AND FILLER BLOCK SECTIONS OF FEB. 1940 ISSUES OF P.C. 3216-2 SUP. 11 AND T-3516-2, AND TEMPORARY P.C. T-3516-2 SUP. 6)



CHECK VALVES

Standard Check Valves of the 1/4", 3/8", 1/2" and 3/4" sizes have brass bodies, while the 1" and 1 1/4" sizes have cast iron bodies with brass bushing, except that those for high pressure (as covered by note B) have brass bodies.

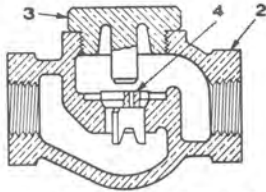

1/4", 3/8", 1/2", 3/4" and 1" Brass Check Valves

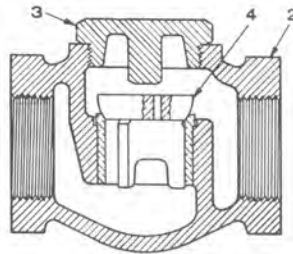

1" and 1 1/4" C.I. Check Valves

Approx. Weights	
Size	Lbs.
1/4"	1
3/8"	1 1/4
1/2"	2 1/4
3/4"	3
1"	4 1/4
1 1/4"	5

		COMPLETE PIECE NUMBERS						
		Size	1/4"	3/8"	1/2"	3/4"	1"	1 1/4"
Check Valve, Complete (without Choke in Valve)			520448	520496	520026	520456	‡519944 ‡520102	520096
Check Valve, Complete (.025" Choke in Valve)			520453					
Check Valve, Complete (.047" Choke in Valve)			522155					
Check Valve, Complete (1/32" Choke in Valve)			522735	520501		520469		
Check Valve, Complete (3/64" Choke in Valve)				520504				
Check Valve, Complete (1/16" Choke in Valve)			525574	520499	520028	520467		
Check Valve, Complete (3/32" Choke in Valve)				520506	520035			
Check Valve, Complete (1/8" Choke in Valve)						520465	‡519945	
Check Valve, Complete (3/16" Choke in Valve)					520031			
Ref. No.		Detail Piece Numbers						
2	Body		520449	520497	520017	520457	‡519938 ‡520103	520097
3	Cap Nut		520455	520455	520021	520461	519941 ‡520101	520101
4	Valve (without Choke)		520452	520452	520027	520460	519940 ‡520100	520100
4	Valve (with .025" Choke)		520454					
4	Valve (with .047" Choke)		520505					
4	Valve (with 1/32" Choke)		520502	520502		520470		
4	Valve (with 3/64" Choke)			520505				
4	Valve (with 1/16" Choke)		520500	520500	520029	520468		
4	Valve (with 3/32" Choke)			520507	520036			
4	Valve (with 1/8" Choke)					520466	519943	
4	Valve (with 3/16" Choke)				520032			

†NOTE A—The Check Valve (with corresponding details) so indicated has oversize valve.

†NOTE B—The Check Valves so indicated are suitable for pressures up to 300 lbs. and have brass, instead of cast iron, body.

Prices will be quoted upon application

Orders should give PIECE NUMBER and NAME of part wanted

SPRING LOADED CHECK VALVES

The standard spring-loaded Check Valves are the same as the non-spring-loaded Check Valves covered on page 2, except for the addition of a spring of the required value. Regularly, the $\frac{3}{8}$ " , $\frac{1}{2}$ " and $\frac{3}{4}$ " sizes have brass bodies (without bushing), while the 1" and $1\frac{1}{4}$ " sizes have bushed cast iron bodies (as illustrated), except that those for high pressure (as covered by note B) have brass bodies.

Approx. Weights	
Size	Lbs.
$\frac{3}{8}$ "	$1\frac{3}{8}$
$\frac{1}{2}$ "	$2\frac{3}{8}$
$\frac{3}{4}$ "	$3\frac{1}{8}$
1"	$4\frac{3}{8}$
$1\frac{1}{4}$ "	14

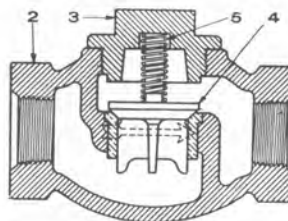

	COMPLETE PIECE NUMBERS					
	Size	$\frac{3}{8}$ "	$\frac{1}{2}$ "	$\frac{3}{4}$ "	1"	$1\frac{1}{4}$ "
Check Valve, Complete (with 2.5 lb. spring)			520033			
Check Valve, Complete (with 3 lb. spring)					523073	‡527908 †526255
Check Valve, Complete (with 5 lb. spring)				520476		
Check Valve, Complete (with 8 lb. spring)					39428	
Check Valve, Complete (with 10 lb. spring)			520034			
Check Valve, Complete (with 15 lb. spring)	520508					
Check Valve, Complete (with 25 lb. spring)	520503					
Check Valve, Complete (with 30 lb. spring)	520509					
Ref. No.	Detail Piece Numbers					
2	Body	520497	520017	520457	39429	‡527676 †526251
3	Cap Nut	520455	520022	520461	39285	526254
4	Valve	520452	520027	520460	39286	526252
5	Spring (2.5 lb.)		*28955			
5	Spring (3 lb.)				*185923	*526253
5	Spring (5 lb.)			*501493		
5	Spring (8 lb.)				*39432	
5	Spring (10 lb.)		*25920			
5	Spring (15 lb.)	*517338				
5	Spring (25 lb.)	*10175				
5	Spring (30 lb.)	*70575				
	Shim (2 for Pc. 520508, 3 for 520509)	27644				

†NOTE A—The Check Valve and body so indicated have the outlet threaded for 2" pipe.

‡NOTE B—The Check Valves so indicated are suitable for pressures up to 300 lbs., have brass, instead of cast iron. body, and are extra large.

*NOTE C—For Spring Identification Table, see Page 7.

Prices will be quoted upon application

Orders should give PIECE NUMBER and NAME of part wanted

DISC CHECK VALVES

Disc Check Valves of $\frac{1}{2}$ " and $\frac{3}{4}$ " sizes have unbushed brass bodies (see Fig. 1), while the 1" size has a bushed cast iron body (see Fig. 2). The bodies of the $\frac{1}{2}$ " and 1" check valves are also provided for a side tap, where required, as illustrated by Fig. 2.

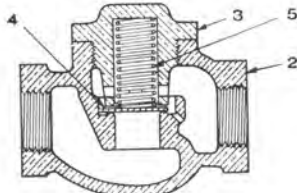

Fig. 1

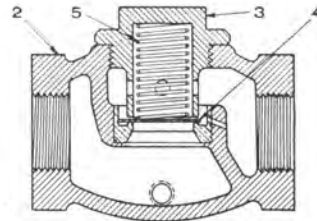

Fig. 2

Approx. Weights— $\frac{1}{2}$ ", 2 $\frac{1}{2}$ Lbs.; $\frac{3}{4}$ ", 3 Lbs.; 1", 4 $\frac{1}{4}$ Lbs.

		COMPLETE PIECE NUMBERS			
		Size	$\frac{1}{2}$ "	$\frac{3}{4}$ "	1"
Check Valve, Complete (without side tap)			519973	520471	519909
Check Valve, Complete (with $\frac{1}{8}$ " side tap)			520048		520118
Ref. No.		Detail Piece Numbers			
2	Body (without side tap)	519970	520472	519901	
2	Body (with side tap)	520049		520119	
3	Cap Nut	519972	520475	519904	
4	Valve	167123	501033	168921	
5	Spring	*182775	*501034	*106416	

$\frac{1}{2}$ " CHECK VALVE WITH WABCO SEAL

This Check Valve is furnished when specially ordered, either with or without the Choke Fitting, as covered by the Complete Pc. No.

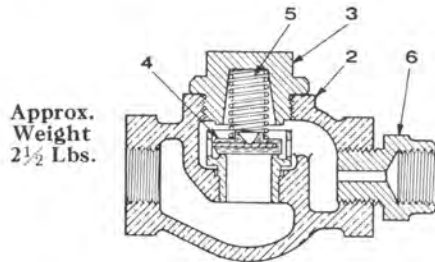

Approx. Weight
2 $\frac{1}{2}$ Lbs.

Piece No. 520286 $\frac{1}{2}$ " Check Valve, Complete, with Choke Fitting having $\frac{5}{32}$ " Drill

Piece No. 520030 $\frac{1}{2}$ " Check Valve, Complete, without Choke Fitting

Pc. No.	Ref. No.	
520019	2	Body
520020	3	Cap Nut
98170	4	Check Valve

Pc. No.	Ref. No.	
*87806	5	Spring
73553	6	Choke Fitting ($\frac{5}{32}$ " Drill)

*NOTE—For Spring Identification Table, see Page 7.

Prices will be quoted upon application

Orders should give PIECE NUMBER and NAME of part wanted

NON-STANDARD CHECK VALVES

The Check Valves covered below are no longer furnished complete, being superseded by those covered on the previous pages. However, repair parts will be furnished in accordance with the schedules listed. In the event of a damaged body for any of these check valves, order a suitable new check valve of the superseding type. The illustrations shown are typical only, and are not exactly representative of all sizes of the Check Valves of the three classes covered.

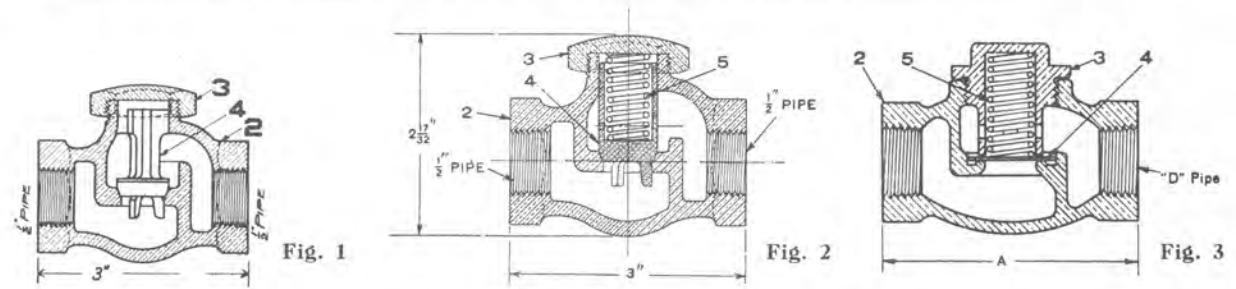

CHECK VALVES (Fig. 1)

Ref. No.		Piece Numbers By Size					
		1/4"	3/8"	1/2"	3/4"	1"	1 1/4"
	Check Valve, Complete (without Choke in Valve)	45062	19738 ‡66864	7473	10021	5615 ‡516523	5621
	Check Valve, Complete (with .025" Choke in Valve)	516960					
	Check Valve, Complete (with 1/32" Choke in Valve)		34605		79715		
	Check Valve, Complete (with 1/16" Choke in Valve)		68652				
	Check Valve, Complete (with 1/8" Choke in Valve)		32863	86289	40149		
	Check Valve, Complete (with 3/32" Choke in Valve)		81003	517235			
	Check Valve, Complete (with 1/8" Choke in Valve)		46836	47200	20554		
	Check Valve, Complete (with 3/32" Choke in Valve)			8280			
	Check Valve, Complete (with 1/16" Choke in Valve)			90528			
2	Body (see note, above)						
3	Cap Nut	45060	7468 ‡45060	7468	10024	5618 ‡5618	5618
4	Valve (without Choke)	45061	19737 ‡45061	7470	10023	5617 ‡5620	5620
4	Valve (.025" Choke)	516959					
4	Valve (1/32" Choke)		34604		79712		
4	Valve (1/16" Choke)		68651				
4	Valve (1/8" Choke)		32862	86286	40150		
4	Valve (3/32" Choke)		80974	517212			
4	Valve (1/8" Choke)		46835	47116	20533		
4	Valve (3/32" Choke)			8288			
4	Valve (1/16" Choke)			90561			

SPRING LOADED CHECK VALVES (Fig. 2)

DISC CHECK VALVES (Fig. 3)

Ref. No.		Piece Numbers by Size			Ref. No.		Piece Numbers by Size		
		3/8"	1/2"	3/4"			1/2"	3/4"	1"
	Check Valve, complete (with 2.5 # Spring)		514567			Check Valve, complete (without side tap)	178593	500946	178594
	Check Valve, complete (with 5 # Spring)	21236	47181	501439		Check Valve, complete (with 1/8" side tap)	177090		
	Check Valve, complete (with 10 # Spring)	21086	514870			Check Valve, complete without side tap, with 15 # Spring and 1/8" Choke in Valve)		508443	
	Check Valve, complete (with 15 # Spring)	517339			2	Body (see note, above)			
	Check Valve, complete (with 25 # Spring)	10035			3	Cap Nut	177205	501032	177197
	Check Valve, complete (with 30 # Spring)	518780			4	Valve (without Choke)	167123	501033	168921
2	Body (see note, above)				4	Valve (with 1/8" Choke)		508442	
3	Cap Nut	10038	7468	501494	5	Spring (normal)*	182775	501034	182776
4	Valve	10037	47199	501492	5	Spring (15 #)*		508440	
5	Spring (2.5 #)*		28955						
5	Spring (5 #)*	21235	47198	501493					
5	Spring (10 #)*	21085	25920						
5	Spring (15 #)*	517338							
5	Spring (25 #)*	10175							
5	Spring (30 #)*	70575							

†NOTE A—The Check Valve (and corresponding details) so indicated has oversize valve.
 †NOTE B—The Check Valve (and corresponding details) so indicated has undersize valve.
 *NOTE C—For Spring Identification Table, see Page 7.

Prices will be quoted upon application
 Orders should give PIECE NUMBER and NAME of part wanted

TYPE C STRAINER AND CHECK VALVE

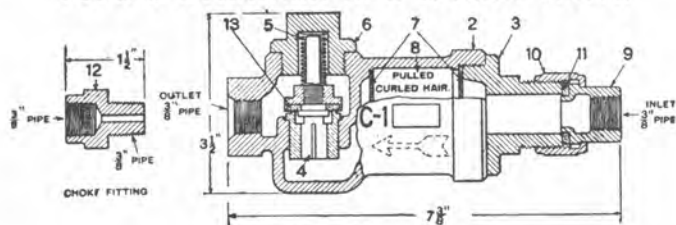

Approx. Net Weight 4 3/8 lbs.

**Type	Complete Pc. Nos.	Spring (Ref. No. 5)		Choke Plug (Ref. No. 12)	
		Value Lbs.	*Pc. No.	Size Choke Inches	Pc. No.
C-1-3-0	24897	3	25921	0
C-1-3-3		3	25921	3/64	503886
C-1-3-4	89386	3	25921	1/16	49564
C-1-3-6	24899	3	25921	3/32	15473
C-1-3-8	66420	3	25921	1/8	25906
C-1-3-11	530004	3	25921	11/64	530003
C-1-5-0	31778	5	31488	0
C-1-5-7	64033	5	31488	7/64	63413
C-1-5-8	39192	5	31488	1/8	25906
C-1-10-0	56163	10	56164	0
C-1-10-8		10	56164	1/8	25906
C-1-15-0	56223	15	56217	0
C-1-15-6	71123	15	56217	3/32	15473
C-1-15-8	63618	15	56217	1/8	25906
C-1-20-0	68859	20	25920	0
C-1-20-8	24898	20	25920	1/8	25906
C-1-20-9	25799	20	25920	9/64	25907
C-1-20-12		20	25920	3/16	96471
C-1-40-0	525028	40	95618	0
C-1-40-8		40	95618	1/8	25906
C-2-5-9	88904	5	31488	.1495	27368

Ref. No.	Name of Part	Piece Numbers	
		C-1	C-2
2	Body	25908	91433
3	Cap Nut	14661	14661
4	Check Valve (includes 13)	25909	25909
5	Spring (see Table above)		
6	Valve Cap	24893	24893
7	Strainer Plate (2 Req'd)	1044	1044
8	Curled Hair		
9	Union Swivel	14294	2166
10	Union Nut	2165	2165
11	Union Gasket	81598	81598
12	Choke Plug (see Table above)		
13	Check Valve Seal	25788	25788

*NOTE A—For Spring Identification Table, see Page 7.

**NOTE B—The letter and first numeral indicates the type; the second numeral the spring weight; and the third numeral the choke size in 64ths of an inch. The C-2 differs from the C-1 in having 1/2" pipe connections.

Prices will be quoted upon application

Orders should give PIECE NUMBER and NAME of part wanted

TYPE D STRAINER AND CHECK VALVE

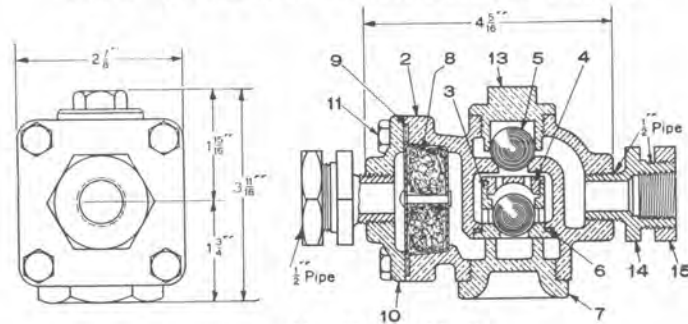

Approx. Net Weight 5 1/4 lbs.

Piece No. 99477 D-1 Strainer and Check Valve, Complete (1/2" Pipe)

Piece No. 509149 D-1 Strainer and Check Valve, Complete (3/8" Pipe) (without Support Fittings)

Pc. No.	Ref. No.		Pc. No.	Ref. No.	
99643	2	Body	99651	10	Strainer Cover
99712		Ball Check Valve and Bush, complete (includes 3, 4 and 5)	68232	11	Strainer Cover Bolt (4 Req'd)
99645	3	Ball Check Valve Bush	99644	13	Ball Check Cap Nut
99646	4	Ball Check Valve Bush Cap Nut	99652		Support Fitting, complete (includes 14 and 15) (2 Req'd for Pc. 99477)
66647	5	Ball Check Valve (2 Req'd)	99653	14	Support Fitting (2 Req'd for Pc. 99477)
99655	6	Ball Check Valve Bush Gasket	99654	15	Jam Nut (2 Req'd for Pc. 99477) 1/2" to 3/8" Reducer (2 Req'd for Pc. 509149)
99647	7	Cap Nut			
99648	8	Strainer			
93316	9	Strainer Cover Gasket			

SPRING IDENTIFICATION

The following table is shown to enable railroad men, storekeepers and all Air Brake men to identify the various springs used in the Check Valves cataloged herein. The actual springs will vary somewhat, due to small differences in wire diameter, coil diameter, number of turns, etc. This tabulation is intended for identification only and should not be used for any other purpose. It does not represent a specification for the springs mentioned.



SPRING IDENTIFICATION

Pc. No.	Approx. Out. Dia. "A"	Approx. Dia. Wire "B"	Approx. Free Ht. "C"	*Approx. No. Turns	Material	Name of Spring	Where Used
10175	1/16"	.051"	1 1/8"	14	Brass	25 # Valve Spring	3/8" Check Valve
12827	1/16"	.064"	2 1/8"	12	Phosphor Bronze	Piston Valve Spring	No. 8 Double Check Valve
21085	1/16"	.04"	1 3/4"	16 1/2	Phosphor Bronze	10 # Valve Spring	3/8" Check Valve
21235	1/16"	.032"	1 1/4"	20	Phosphor Bronze	5 # Valve Spring	3/8" Check Valve
25920	1/4"	.072"	1 1/2"	8 1/2	Phosphor Bronze	Valve Spring	1/2" Check Valve (10 #); C-1 Strainer and Check Valve (20 #)
25921	1/4"	.0403"	1 3/4"	15	Phosphor Bronze	3 # Valve Spring	C-1 Strainer and Check Valve
28955	1/2"	.040"	1 1/2"	12 1/2	Phosphor Bronze	2.5 # Valve Spring	1/2" Check Valve
31488	1/4"	.045"	1.77"	14	Phosphor Bronze	5 # Valve Spring	
31810	1/4"	.091"	2 1/8"	12	Phosphor Bronze	Double Piston Spring	No. 14 Double Check Valve
39432	1/2"	.081"	1 1/4"	10	Phosphor Bronze	8 # Valve Spring	1" Check Valve
47198	5/8"	.065"	1 1/2"	9	Brass	5 # Valve Spring	1/2" Check Valve
51551	1/4"	.064"	1 1/4"	8	Phosphor Bronze	Aux. Res. C.V. Spring	No. 14 Double Check Valve
56164	1/2"	.064"	1 1/4"	11 1/2	Phosphor Bronze	10 # Valve Spring	C-1 Strainer and Check Valve
56217	1/2"	.072"	1 1/2"	9 1/2	Phosphor Bronze	15 # Valve Spring	C-1 Strainer and Check Valve
70575	1/4"	.041"	1 1/2"	12 1/2	Steel	30 # Valve Spring	3/8" Check Valve
87806	1/2"	.032"	1 3/4"	14	Phosphor Bronze	Valve Spring	1/2" Check Valve with WABCO Seal
95618	1/2"	.080"	1 3/4"	6 1/2	Steel	40 # Valve Spring	C-1 Strainer and Check Valve
501034	1/4"	.050"	1 1/2"	12	Phosphor Bronze	Valve Spring	3/4" Disc Check Valve
501493	1/4"	.057"	2 1/8"	10	Phosphor Bronze	5 # Valve Spring	3/4" Check Valve
508440	1/4"	.080"	2 1/2"	10	Phosphor Bronze	15 # Valve Spring	3/4" Disc Check Valve
510682	1/4"	.057"	2 1/8"	8 1/2	Phosphor Bronze	Valve Spring	No. 15-C Dbl. Ch. Valve
517338	1/4"	.045"	1 1/4"	14 1/4	Phosphor Bronze	15 # Valve Spring	3/8" Check Valve
9694	1/4"	.022"	1 3/8"	11 1/2	Brass	Valve Spring	No. 22 Double Check Valve
526253	1 1/8"	.072"	3"	5 1/4	Phosphor Bronze	3 # Valve Spring	1 1/4" Check Valve
106416	1/4"	.047"	2"	12	Steel	Valve Spring	1" Disc Check Valve
182775	1/4"	.047"	1 3/4"	13	Stainless St.	Valve Spring	1/2" Disc Check Valve
182776	1/4"	.047"	2"	12	Stainless St.	Valve Spring	1" Disc Check Valve
185923	1/4"	.047"	2 1/4"	19	Steel	3 # Valve Spring	1" Check Valve

*NOTE—Number of turns for each spring, counted between extreme ends of the wire.

Prices will be quoted upon application

Orders should give PIECE NUMBER and NAME of part wanted

No. 2 DOUBLE CHECK VALVE

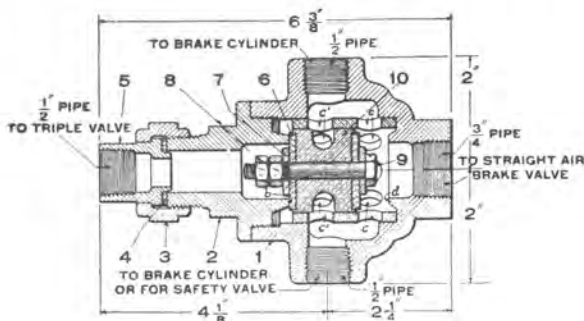

Approx. Net Weight 5 lbs.

Piece No. 5098 No. 2 Double Check Valve, complete

Pc. No.	Ref. No.	Description
2607	1	Body
5097	2	Cap
2165	3	1/2" Union Nut
81598	4	1/2" Union Gasket
2166	5	1/2" Union Swivel
2608		Piston Valve, complete, (includes 9, 10 and two of 6 and 7)
2613	6	Valve Seal (2 Req'd)
2614	7	Washer (2 Req'd)
2588	8	Nut (2 Req'd)
5192	9	Bolt, Nuts and Cotter (includes two of 8)
2612	10	Valve

No. 12-B DOUBLE CHECK VALVE

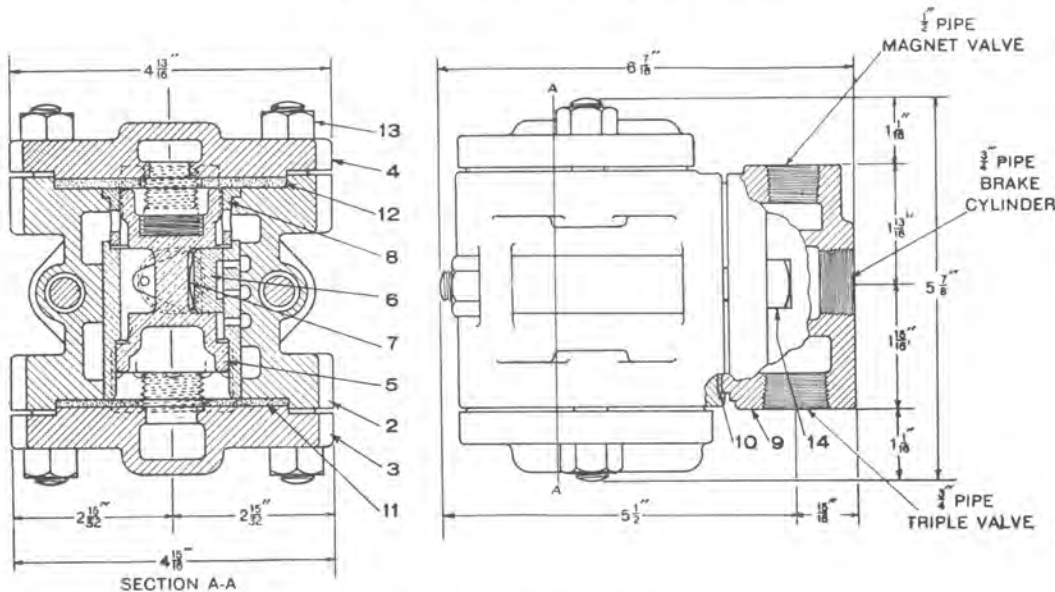

Approx. Net Weight 17 lbs.

Piece No. 72721 No. 12-B Double Check Valve with Type "A" Pipe Bracket, complete

Piece No. 72725 No. 12-B Double Check Valve with Type "B" Pipe Bracket, complete

Piece No. 72838 No. 12-B Double Check Valve, complete, less Pipe Bracket

Pc. No.	Ref. No.	Description	Pc. No.	Ref. No.	Description
69460	2	Body (includes 8 and four of 13)	27269	9	Type "A" Pipe Bracket
28193	3	Cap for Automatic End	27072	9	Type "B" Pipe Bracket (with supporting lug)
28194	4	Cap for Electric End	27086	10	Pipe Bracket Gasket
72724	5	Double Piston, complete (includes 6 and 7)	28196	11	Gasket (Automatic End)
72722	6	Slide Valve	28198	12	Gasket (Electric End)
27083	7	Slide Valve Spring	27266	13	Stud and Nut (4 Req'd)
27080	8	Piston Bush	25143	14	Bolt and Nut (2 Req'd)

NOTE A—No. 12 and No. 12-A Double Check Valves—Repair parts for the No. 12 are the same as shown above; for the No. 12-A Double Piston, Complete, Piece No. 72724 should be substituted for the old Double Piston, thus converting it to a No. 12-B Valve.

Prices will be quoted upon application

Orders should give PIECE NUMBER and NAME of part wanted

No. 8 DOUBLE CHECK VALVE

Piece No. 12833 No. 8 Double Check Valve, complete

Pc. No.	Ref. No.	Description
12834	2	Body, bushed
12832	3	Cap
2165	4	1/2" Union Nut
81598	5	1/2" Union Gasket
2166	6	1/2" Union Swivel
12835	7	Piston Valve, complete (includes 7 and two of 8, 9, 10, 11 and 12)
12826	7	Piston Valve Body
12829	8	Valve Seal (2 Req'd)
12827	9	Spring (2 Req'd)
12828	10	Equalizing Stem (2 Req'd)
12830	11	Washer (2 Req'd)
12831	12	Retaining Nut (2 Req'd)

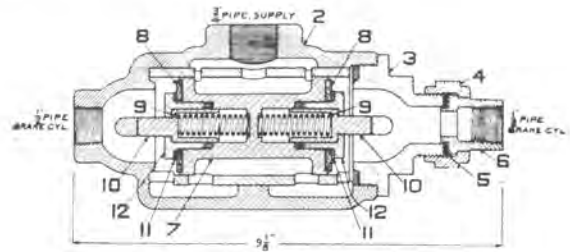

Approx. Net Weight 10 lbs.

No. 14 DOUBLE CHECK VALVE

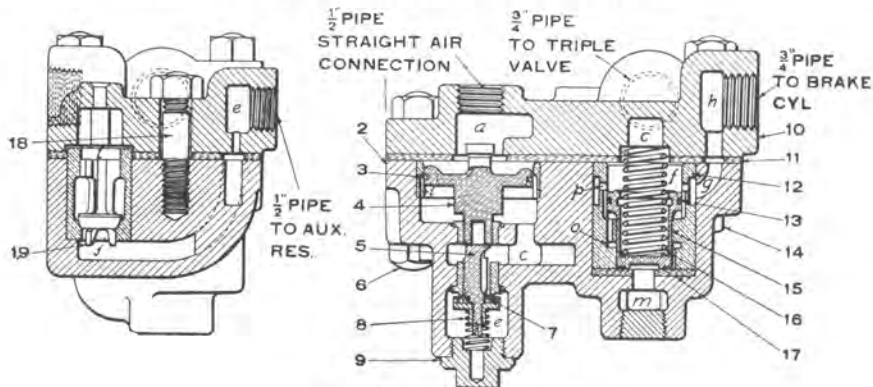

Approx. Net Weight 17 1/4 lbs.

Piece No. 31790 No. 14 Double Check Valve, complete

Piece No. 83644 No. 14 Double Check Valve, complete, with 1/4" Auxiliary Reservoir Choke

Piece No. 44907 No. 14 Double Check Valve, complete, less Pipe Bracket

Pc. No.	Ref. No.	Description	Pc. No.	Ref. No.	Description
31833	2	Body	14560	9	Auxiliary Reservoir Check Valve Cap Nut
81221	3	Supply Valve Piston Ring (1st Repair)	31793	10	Pipe Bracket, complete
11950	3	Supply Valve Piston Ring (2nd Repair)	83616	10	Pipe Bracket, complete, with 1/4" Auxiliary Reservoir Choke
14284	3	Supply Valve Piston Ring (3rd Repair)	31808	11	Pipe Bracket Gasket
13136	4	Supply Valve Piston, complete (includes 3)	31805	12	Double Piston Bush
*51529	5	Auxiliary Reservoir Check Valve, complete (includes 7)	31672	13	Double Piston Ring (1st and 2nd Repair)
15105	6	1/2"x2 3/4" Tee Head Bolt (2 Req'd)	47923	13	Double Piston Ring (3rd Repair)
51528	7	Valve Seal	11008	14	1/2"x3 1/4" Tee Head Bolt (2 Req'd)
†51551	8	Auxiliary Reservoir Check Valve Spring	31834	15	Double Piston, complete (includes 13)
			†31810	16	Double Piston Spring
			31542	17	Double Piston Seat
			44275	18	1/2"x2 1/4" Stud with Hex. Nut
			7470	19	Exhaust Check Valve

*NOTE A—When New Style Auxiliary Reservoir Check Valve Pc. 51529 is applied, Spring Pc. 51551 must be applied also.

†NOTE B—For Spring Identification Table, see page 7.

Prices will be quoted upon application

Orders should give PIECE NUMBER and NAME of part wanted

No. 15 DOUBLE CHECK VALVE

Piece No. 40182 No. 15 Double Check Valve, complete

Pc. No.	Ref. No.	Description
40181	2	Body, complete
40178	3	Cap (2 Req'd)
507895	4	Check Valve
514261	5	Gasket (2 Req'd)
2165	6	1/2" Union Nut
2166	7	1/2" Union Swivel
81598	8	1/2" Union Gasket
16809	9	Square Head Bolt and Nut (2 Req'd)

Approx. Net Weight 6 3/4 lbs.

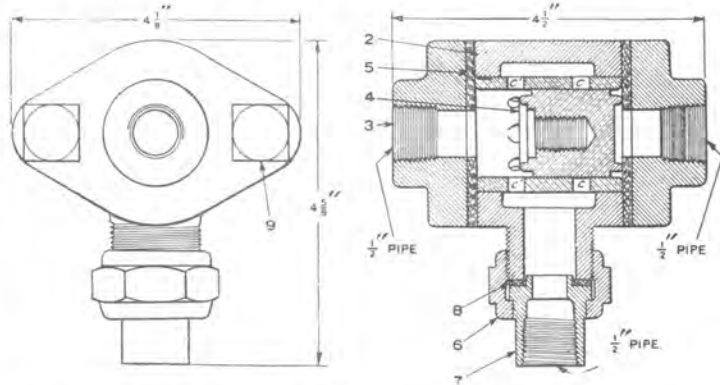

No. 15-C DOUBLE CHECK VALVE

Piece No. 509593 No. 15-C Double Check Valve, complete

Pc. No.	Ref. No.	Description
509592	2	Body
508680	3	Cap
509068	4	Check Valve
72267	5	Gasket (2 Req'd)
2165	6	1/2" Union Nut
2166	7	1/2" Union Swivel
81598	8	1/2" Union Gasket
16809	9	Square Head Bolt and Nut (2 Req'd)
*510682	10	Spring
510363	11	Spring Guide
99344	12	Cap (Spring End)

Approx. Net Weight 6 3/4 lbs.

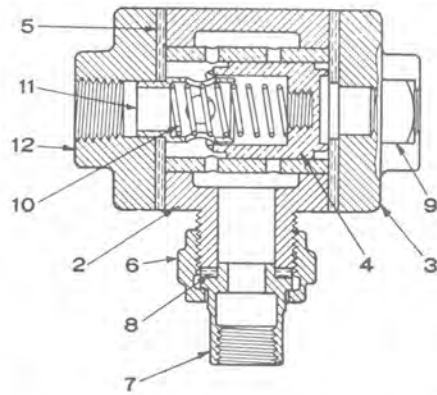
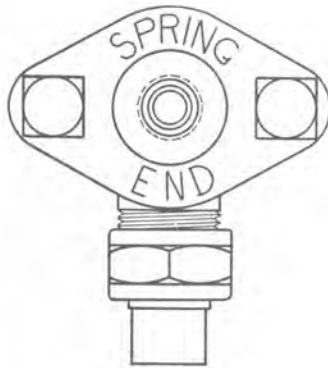

No. 16 AND 16-A DOUBLE CHECK VALVES

Approx. Net Weight 11 lbs.

Piece No. 55654 No. 16 Double Check Valve, complete (1" Pipe Connections)

Piece No. 515991 No. 16-A Double Check Valve, complete (3/4" Pipe Connections)

Pc. No.	Ref. No.	Description	Pc. No.	Ref. No.	Description
55660	2	Body	87726	8	1" Union Gasket
55666	3	Cap (Main Res. Side) (for No. 16)	25126	9	Bolt and Nut for Caps (2 Req'd)
515981	3	Cap (Main Res. Side) (for No. 16-A)	55666	10	Cap (Emergency Side) (for No. 16)
55670	4	Check Valve	515981	10	Cap (Emergency Side) (for No. 16-A)
55668	5	Gasket for Cap (Main Res. Side)	55668	11	Gasket for Cap (Emergency Side)
1749	6	1" Union Nut	6983		1" x 3/4" Reducing Bush (for No. 16-A)
1750	6	1" Union Swivel			

*NOTE A—For Spring Identification Table, see Page 7.

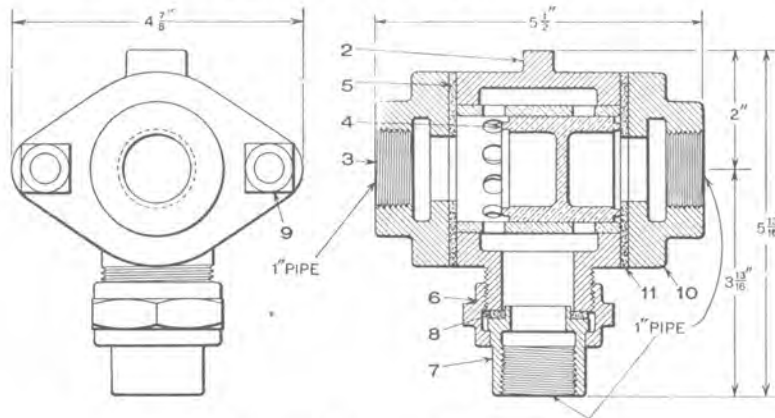

Prices will be quoted upon application

Orders should give PIECE NUMBER and NAME of part wanted

No. 18-A DOUBLE CHECK VALVE

Piece No. 521774 No. 18-A Double Check Valve, complete (with 1/4" Pipe Taps)

Piece No. 508813 No. 18-A Double Check Valve, complete (with 3/8" Pipe Taps)

Pc. No.	Ref. No.	Description
521777	2	Body (with 1/4" Pipe Tap)
508758	2	Body (with 3/8" Pipe Tap)
521778	3	Flange (with 1/4" Pipe Tap) (2 Req'd for Pc. 521774)
508759	3	Flange (with 3/8" Pipe Tap) (2 Req'd for Pc. 508813)
83360	4	Check Valve
83362	5	Check Valve Seal (2 Req'd)
96053	6	1/4"x5/8" Bolt (4 Req'd)

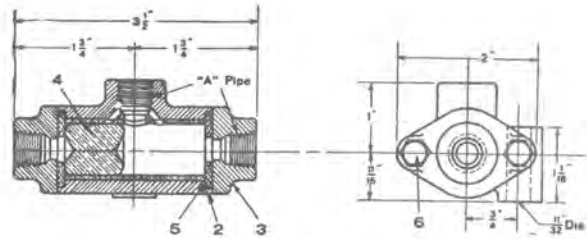

Approx. Net Weight 1 1/2 lbs.

No. 19 DOUBLE CHECK VALVE

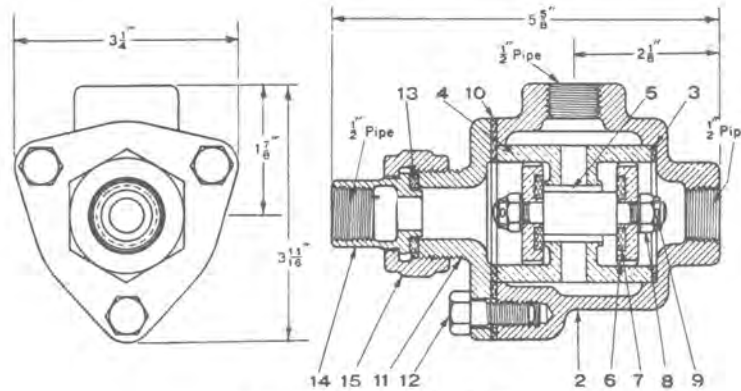

Approx. Net Weight 5 lbs.

Piece No. 88766 No. 19 Double Check Valve, complete

Pc. No.	Ref. No.	Description
89033	2	Body
88437	3	Bushing Seal
89034	4	Bushing
89035	5	Piston Stem
89036	6	Piston (2 Req'd)
30729	7	Piston Seal (2 Req'd)
79069	8	Castle Nut (2 Req'd)
5735	9	Cotter (2 Req'd)
88436	10	Cover Gasket
89037	11	Cover
38257	12	Hex. Hd. Cap Screw (3 Req'd)
81598	13	1/2" Union Gasket
2166	14	1/2" Union Swivel
2165	15	1/2" Union Nut

No. 22 DOUBLE CHECK VALVE

Piece No. 529003 No. 22 Double Check Valve, complete

Pc. No.	Ref. No.	Description
529004	2	Body
529011	3	Cover (2 Req'd)
529009	4	Check Valve (2 Req'd)
529010	5	Cover Gasket (2 Req'd)
15784	9	Cover Cap Screw (4 Req'd)
*9694	10	Check Valve Spring (2 Req'd)
529007	11	Valve

Approx. Net Weight 3 lbs.

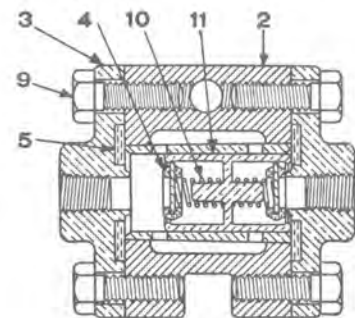

*NOTE—For Spring Identification Table, see Page 7.

Prices will be quoted upon application

Orders should give PIECE NUMBER and NAME of part wanted

FILLER BLOCK WITH DOUBLE CHECK VALVE

The Filler Block with Double Check Valve is for use with freight car brake equipments employing the K or H Type Triple Valves in heavy grade service when it is desired to add the straight air control to the automatic brake. This filler block is also used with combined automatic and straight air brake equipments on self-propelled vehicles such as steam shovels, derrick cars, etc. The filler block is inserted between the triple valve and the reservoir, two $\frac{5}{8}$ "x $\frac{1}{8}$ " studs, Pc. 13435 being required to secure the K-1 or H-1 Triple Valve and Filler Block to the Reservoir, and three studs, Pc. 13435 being required to secure the K-2 or H-2 Triple Valve and Filler Block. An extra gasket suitable for triple valve employed is also required.

(For Use with H-1 or K-1 Triple Valve)

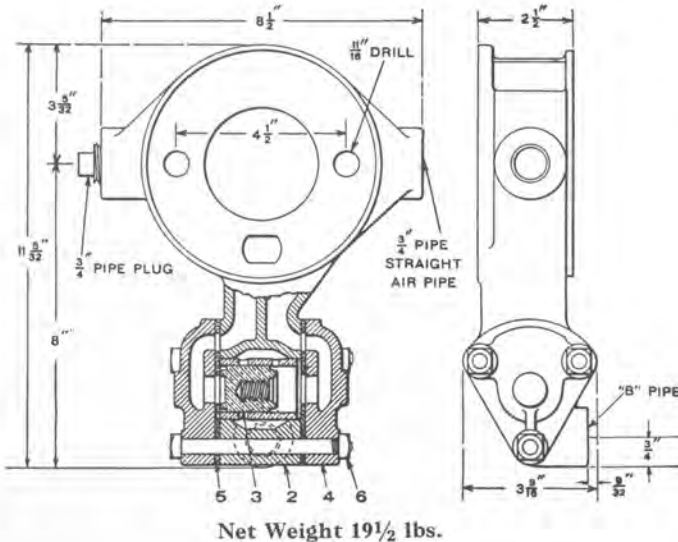

Piece No. 48280 Filler Block with Double Check Valve, complete, having one small vent port in the straight air end of check valve bushing (as shown in opposite cut).

Piece No. 79648 Filler Block with Double Check Valve, complete, having large size vent holes in the straight air end of check valve bushing to provide for application and release times. (See cut at bottom of page covering filler block for H-2 or K-2 Triple Valve for illustration of ports).

Pc. No.	Ref. No.	Description
47838	2	Body, complete, (includes Pc. 18023, for Pc. No. 48280)
79695	2	Body, complete, (includes Pc. 18023, for Pc. No. 79648)
507895	3	Check Valve
40317	4	Cover (2 Req'd)
75035	5	Cover Gasket (2 Req'd)
25206	6	$\frac{3}{8}$ "x $\frac{1}{2}$ " Sq. Head Bolt and Nut (3 Req'd)
18023		$\frac{3}{4}$ " Pipe Plug

(For Use with H-2 or K-2 Triple Valve)

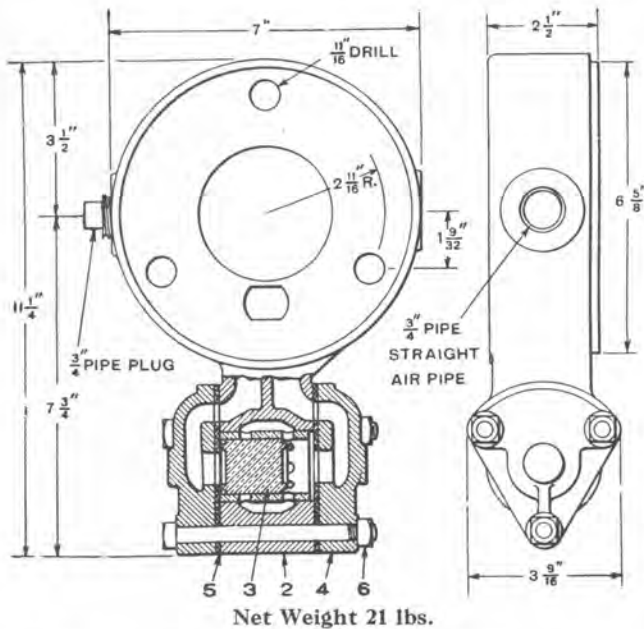

Piece No. 40798 Filler Block with Double Check Valve, complete, having one small vent port in the straight air end of the check valve bushing. (See cut above covering filler block for H-1 or K-1 Triple Valve for illustration of ports).

Piece No. 78744 Filler Block with Double Check Valve, complete, having large size vent holes in the straight air end of check valve bushing to provide for application and release times (As shown in opposite cut).

Pc. No.	Ref. No.	Description
40770	2	Body, complete, (includes Pc. 18023) for Pc. No. 40798
78720	2	Body, complete, (includes Pc. 18023) for Pc. No. 78744
507895	3	Check Valve
40317	4	Cover (2 Req'd)
75035	5	Cover Gasket (2 Req'd)
25206	6	$\frac{3}{8}$ "x $\frac{1}{2}$ " Sq. Head Bolt and Nut (3 Req'd)
18023		$\frac{3}{4}$ " Pipe Plug

*NOTE—If Filler Block with Double Check Valve, for use with H-1 or K-1 Triple Valve, having cover for Automatic Side tapped for $\frac{1}{4}$ " Drain Cock, complete, Pc. No. 47881, is desired, orders should so state and Check Valve Cover tapped for $\frac{1}{4}$ " Drain Cock, complete, Pc. No. 48202, will be substituted for one Cover, Pc. No. 40317, listed above.

Prices will be quoted upon application

Orders should give PIECE NUMBER and NAME of part wanted

PNEUPHONIC HORNS, WHISTLES and WHISTLE VALVES

Parts Catalog No. 3224-1

July, 1954

(Superseding Issue of August, 1949)



Westinghouse Air Brake
COMPANY

AIR BRAKE DIVISION



WILMERDING, PA.

E-2B-1 AND E-2B-2 PNEUPHONIC HORNS

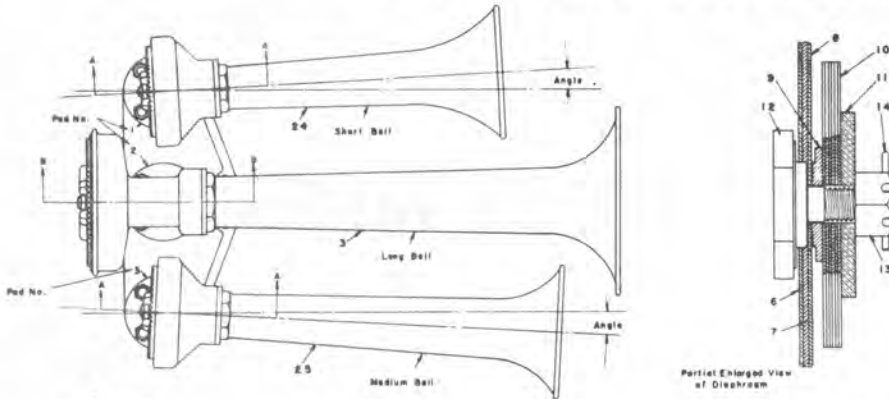

E-2B-1 Net Wt. 36 lbs.
E-2B-2 Net Wt. 33½ lbs.

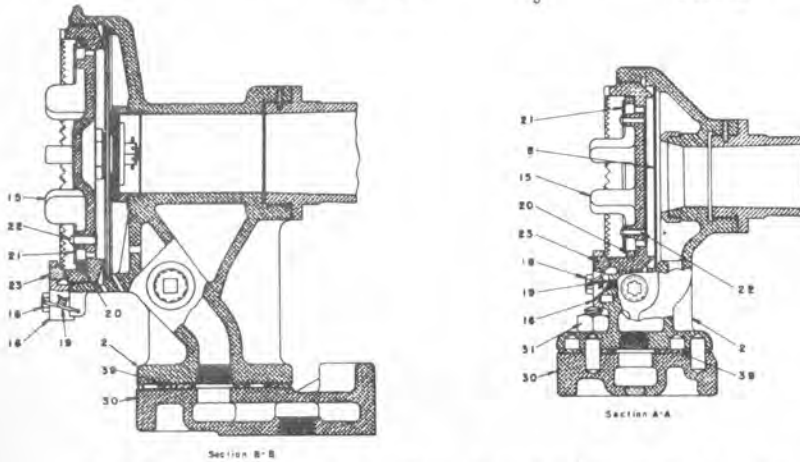

Pc No. A546526 Suffix Numbers	Pad No.					
	1		2		3	
	Bell	Angle	Bell	Angle	Bell	Angle
-0100	Short	3°	Long	0°	Med.	3°
-0200	Short	177°	Long	180°	Med.	177°
-0300	Med.	3°	Long	0°	Short	3°
-0400	Med.	177°	Long	180°	Short	177°
-0500	Short	3°	Long	180°	Med.	3°
-0600	Short	177°	Long	0°	Med.	177°
-0700	Med.	3°	Long	180°	Short	3°
-0800	Med.	177°	Long	0°	Short	177°
-0900	Short	3°	Long	0°	Med.	177°
-1000	Short	177°	Long	180°	Med.	3°
-1100	Med.	177°	Long	0°	Short	3°
-1200	Med.	3°	Long	180°	Short	177°
-1300	Short	177°	Long	0°	Med.	3°
-1400	Short	3°	Long	180°	Med.	177°
-1500	Med.	3°	Long	0°	Short	177°
-1600	Med.	177°	Long	180°	Short	3°

- *546526 E-2B-1 Pneuphonic Horn, Complete (See Notes A and B on page 3)
- *550759 E-2B-1 Pneuphonic Horn, Complete, less long Bell (See Notes A and B on page 3)
- 546525 B-7-25 Pneuphonic Horn, Complete (Short Bell) (See page 5)
- 546519 B-7-21 Pneuphonic Horn, Complete (Medium Bell) (See page 5)
- 546789 E-2 Pneuphonic Horn, Complete (Long Bell) (See page 4)
- 546527 Pipe Bracket, Complete (See Ref. Nos. 30 through 39, below)
- *546399 E-2B-2 Pneuphonic Horn, Complete (See Notes A and B on page 3)
- 546507 B-7-36 Pneuphonic Horn, Complete (Short Bell) (See page 5)
- 546506 B-7-30 Pneuphonic Horn, Complete (Medium Bell) (See page 5)
- 546508 E-24 Pneuphonic Horn, Complete (Long Bell) (See Ref. No. 2 through Pc. 51309 below)
- 546527 Pipe Bracket, Complete (See Ref. Nos. 30 through 31b, below)

*When ordering E-2B-1 and E-2B-2 Pneuphonic Horns, in every case the Complete Piece Number must be followed by a Suffix Numeral signifying the assembled position of the Horns, as shown in the schedule above.

Pc. No.	Ref. No.	Pc. No.	Ref. No.
546508	E-24 Pneuphonic Horn, Complete	546517	15 Cover, Complete (includes 20, 21 and three of 22)
546510	2 Body, Complete (includes two of Pc. 51309)	538771	16 Cover Clamp
543710	3 Bell	518066	18 ¼" x ¾" Cover Clamp Cap Screw
515411	Diaphragm, Complete (includes 6, 7, 8, 9, 11, 12, 13, 14 and six of 10)	534542	19 Locking Wire
515406	6 Outer Diaphragm	519931	20 Breather Felt
515407	7 Intermediate Diaphragm	520141	21 Breather Cover
515408	8 Inner Diaphragm	544177	22 ⅜" x 1⅜" Rivet (3 Req'd)
515410	9 Spacer	540635	23 Locking Tip
512773	10 Small Diaphragm (6 Req'd)	51309	½" Pipe Plug (2 Req'd)
512774	11 Washer	546527	30 Pipe Bracket, Complete (includes ten of 31a and 31b)
515405	12 Diaphragm Bolt	500871	31a ½" x 1¾" Horn Mounting Stud (10 Req'd)
520189	13 Castle Nut	10829	31b ½" Nut (10 Req'd)
93261	14 ⅜" x ¾" Cotter	540522	39 Gasket (3 Req'd)

Prices will be quoted upon application.
Orders should give PIECE NUMBER and NAME of part wanted.

E-2B-3 PNEUPHONIC HORN

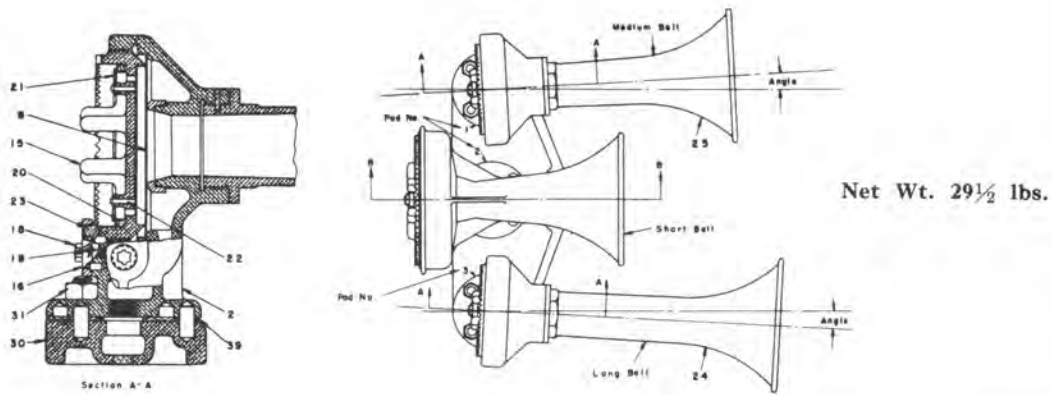

Net Wt. 29½ lbs.

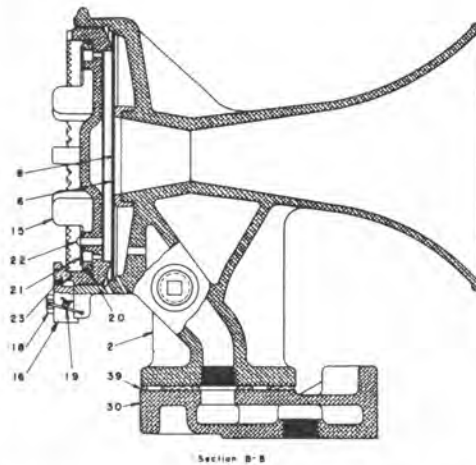

Pc. No. A546400 Suffix Numbers	Pad No.					
	1		2		3	
	Bell	Angle	Bell	Angle	Bell	Angle
-0100	Med.	3°	Short	0°	Long	3°
-0200	Med.	177°	Short	180°	Long	177°
-0300	Long	3°	Short	0°	Med.	3°
-0400	Long	177°	Short	180°	Med.	177°
-0500	Med.	3°	Short	180°	Long	3°
-0600	Med.	177°	Short	0°	Long	177°
-0700	Long	3°	Short	180°	Med.	3°
-0800	Long	177°	Short	0°	Med.	177°
-0900	Med.	3°	Short	0°	Long	177°
-1000	Med.	177°	Short	180°	Long	3°
-1100	Long	177°	Short	0°	Med.	3°
-1200	Long	3°	Short	180°	Med.	177°
-1300	Med.	177°	Short	0°	Long	3°
-1400	Med.	3°	Short	180°	Long	177°
-1500	Long	3°	Short	0°	Med.	177°
-1600	Long	177°	Short	180°	Med.	3°

- *546400 E-2B-3 Pneuphonic Horn, Complete (See Notes A and B)
- 546502 E-44 Pneuphonic Horn, Complete (Short Bell) (See Ref. No. 2 through Pc. 51309, below)
- 546507 B-7-36 Pneuphonic Horn, Complete (Medium Bell) (See page 5)
- 546506 B-7-30 Pneuphonic Horn, Complete (Long Bell) (See page 5)
- 546527 Pipe Bracket, Complete (See Ref. Nos. 30 through 31b, below)

*When ordering E-2B-3 Pneuphonic Horn, in every case the Complete Piece Number must be followed by a Suffix Numeral signifying the assembled position of the Horns, as shown in the schedule above.

<table border="0"> <tr> <th>Pc. No.</th> <th>Ref. No.</th> <th></th> </tr> <tr> <td>546502</td> <td></td> <td>E-44 Pneuphonic Horn, Complete</td> </tr> <tr> <td>546504</td> <td>2</td> <td>Horn Body with Integral Bell (includes two of Pc. 51309)</td> </tr> <tr> <td>515406</td> <td>6</td> <td>Outer Diaphragm</td> </tr> <tr> <td>519935</td> <td>8</td> <td>Inner Diaphragm</td> </tr> <tr> <td>546517</td> <td>15</td> <td>Cover, Complete (includes 20, 21 and three of 22)</td> </tr> <tr> <td>538771</td> <td>16</td> <td>Cover Clamp</td> </tr> <tr> <td>518066</td> <td>18</td> <td>¼" x ¾" Cover Clamp Cap Screw</td> </tr> <tr> <td>534542</td> <td>19</td> <td>Locking Wire</td> </tr> <tr> <td>519931</td> <td>20</td> <td>Breather Felt</td> </tr> </table>	Pc. No.	Ref. No.		546502		E-44 Pneuphonic Horn, Complete	546504	2	Horn Body with Integral Bell (includes two of Pc. 51309)	515406	6	Outer Diaphragm	519935	8	Inner Diaphragm	546517	15	Cover, Complete (includes 20, 21 and three of 22)	538771	16	Cover Clamp	518066	18	¼" x ¾" Cover Clamp Cap Screw	534542	19	Locking Wire	519931	20	Breather Felt	<table border="0"> <tr> <th>Pc. No.</th> <th>Ref. No.</th> <th></th> </tr> <tr> <td>520141</td> <td>21</td> <td>Breather Cover</td> </tr> <tr> <td>544177</td> <td>22</td> <td>⅜" x 1¼" Breather Cover Rivet (3 Req'd)</td> </tr> <tr> <td>540635</td> <td>23</td> <td>Cover Locking Tip</td> </tr> <tr> <td>51309</td> <td></td> <td>½" Pipe Plug (2 Req'd)</td> </tr> <tr> <td>546527</td> <td>30</td> <td>Pipe Bracket, Complete (includes ten of 31a and 31b)</td> </tr> <tr> <td>500871</td> <td>31a</td> <td>½" x 1¾" Horn Mounting Stud (10 Req'd)</td> </tr> <tr> <td>10829</td> <td>31b</td> <td>½" Nut (10 Req'd)</td> </tr> <tr> <td>540522</td> <td>39</td> <td>Gasket (3 Req'd)</td> </tr> </table>	Pc. No.	Ref. No.		520141	21	Breather Cover	544177	22	⅜" x 1¼" Breather Cover Rivet (3 Req'd)	540635	23	Cover Locking Tip	51309		½" Pipe Plug (2 Req'd)	546527	30	Pipe Bracket, Complete (includes ten of 31a and 31b)	500871	31a	½" x 1¾" Horn Mounting Stud (10 Req'd)	10829	31b	½" Nut (10 Req'd)	540522	39	Gasket (3 Req'd)
Pc. No.	Ref. No.																																																									
546502		E-44 Pneuphonic Horn, Complete																																																								
546504	2	Horn Body with Integral Bell (includes two of Pc. 51309)																																																								
515406	6	Outer Diaphragm																																																								
519935	8	Inner Diaphragm																																																								
546517	15	Cover, Complete (includes 20, 21 and three of 22)																																																								
538771	16	Cover Clamp																																																								
518066	18	¼" x ¾" Cover Clamp Cap Screw																																																								
534542	19	Locking Wire																																																								
519931	20	Breather Felt																																																								
Pc. No.	Ref. No.																																																									
520141	21	Breather Cover																																																								
544177	22	⅜" x 1¼" Breather Cover Rivet (3 Req'd)																																																								
540635	23	Cover Locking Tip																																																								
51309		½" Pipe Plug (2 Req'd)																																																								
546527	30	Pipe Bracket, Complete (includes ten of 31a and 31b)																																																								
500871	31a	½" x 1¾" Horn Mounting Stud (10 Req'd)																																																								
10829	31b	½" Nut (10 Req'd)																																																								
540522	39	Gasket (3 Req'd)																																																								

NOTE A—The Complete Piece Numbers of the E-2B-1, E-2B-2 and E-2B-3 Pneuphonic Horns do not include Strainers, but in every installation there must be included the ½" OB-2 Air Strainer, Pc. 6997.

NOTE B—The details of the E-2B-1, E-2B-2 and E-2B-3 Pneuphonic Horns are all interchangeable with the corresponding details of the former standard E-2B-1, E-2B-2 and E-2B-3 Pneuphonic Horns, Piece Numbers 543699, 543702 and 543182 respectively.

Prices will be quoted upon application.
Orders should give PIECE NUMBER and NAME of part wanted.

B-7 PNEUPHONIC HORNS

Net Weight
 With 12" Bell—6 lbs.
 With 14 $\frac{1}{4}$ " Bell—7 lbs.
 With 17" Bell—7 $\frac{1}{2}$ lbs.
 With 20" Bell—7 $\frac{3}{4}$ lbs.

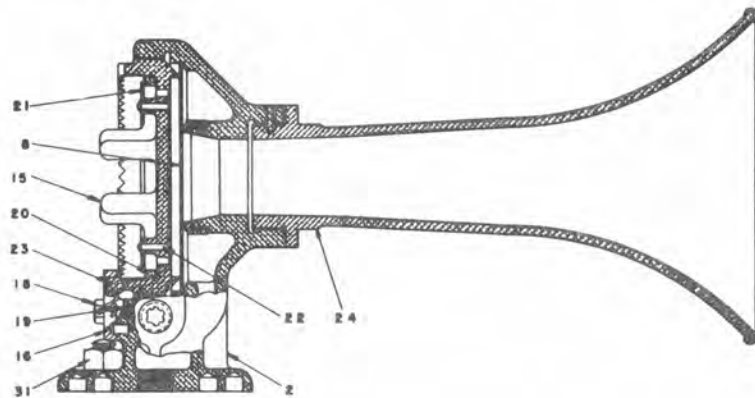

- Piece No. 546507 B-7-36 Pneuphonic Horn, Complete (12" Bell)
 Piece No. 546506 B-7-30 Pneuphonic Horn, Complete (14 $\frac{1}{4}$ " Bell)
 Piece No. 546525 B-7-25 Pneuphonic Horn, Complete (17" Bell)
 Piece No. 546519 B-7-21 Pneuphonic Horn, Complete (20" Bell)

Pc. No.	Ref. No.		Pc. No.	Ref. No.	
546520	2	Horn Body, Complete (includes two of Pc. 56992)	543634	21	Breather Cover
543630	8	Diaphragm	545927	22	$\frac{3}{64}$ " x $1\frac{1}{16}$ " Breather Cover Rivet (4 Req'd)
546523	15	Cover, Complete (includes 15, 20, 21 and four of 22)	540635	23	Cover Locking Tip
543635	16	Cover Clamp	543637	24	Bell (12")
539280	18	$\frac{1}{4}$ " x $\frac{5}{8}$ " Cover Clamp Screw	543627	24	Bell (14 $\frac{1}{4}$ ")
534542	19	Lock Wire	543707	24	Bell (17")
543633	20	Breather Felt	543706	24	Bell (20")
			56992		$\frac{3}{8}$ " Pipe Plug (2 Req'd)

NOTE—The details of the B-7 Pneuphonic Horns, Piece Nos. 546507, 546506, 546525 and 546519, are interchangeable with the corresponding details of the former standard B-7 horns, Piece Nos. 543636, 543626 and 543705 respectively. A $\frac{3}{8}$ " OB-1 Strainer, Pc. 79452, is recommended for all B-7 Pneuphonic Horn installations.

B-6 PNEUPHONIC HORNS

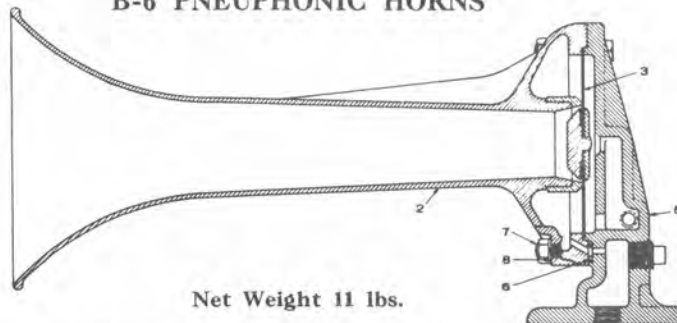

Net Weight 11 lbs.

The B-6 Pneuphonic Horn, Piece Nos. 524493 and 520013, is no longer furnished complete, being superseded by the B-7 Pneuphonic Horns listed above. However, the following repair details will be furnished for horns now in service.

Pc. No.	Ref. No.		Pc. No.	Ref. No.	
98871	2	Bell	9469	8	Lock Washer (6 Req'd)
94089	3	Diaphragm	505842		$\frac{3}{8}$ " Pipe Plug
520040	5	Angle Bracket (includes Pc. 505842)	79452		$\frac{3}{8}$ " OB-1 Air Strainer (for details see Part Catalog 3216-2, Sup. 11)
88762	6	Port Gasket			
519471	7	Hex Hd. Bolt and Nut (6 Req'd)			

Prices will be quoted upon application.

Orders should give PIECE NUMBER and NAME of part wanted.

A-6 PNEUPHONIC HORN

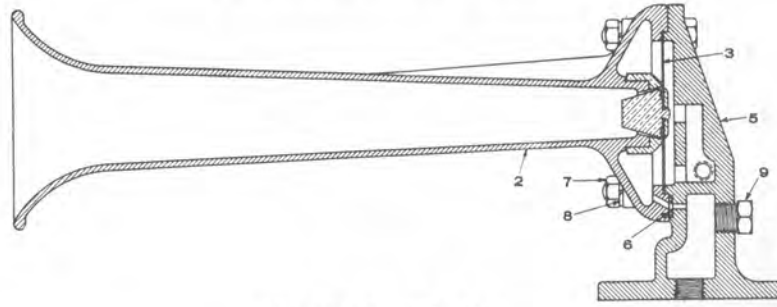
Net Weight 10 $\frac{3}{4}$ lbs.

Piece No. 524484 A-6 Pneuphonic Horn, complete with Strainer

Piece No. 517845 A-6 Pneuphonic Horn, complete less Strainer

Pc. No.	Ref. No.	Pc. No.	Ref. No.
94712	2	14840	7b $\frac{5}{16}$ " Hex Nut (6 Req'd)
517670	3	9469	8 Lock Washer (6 Req'd)
517848	5	505842	9 $\frac{3}{8}$ " Pipe Plug
88762	6	79452	$\frac{3}{8}$ " OB-1 Air Strainer (for details see Part Catalog 3216-2 Sup. 11)
29577	7a		
			Part Catalog 3216-2 Sup. 11)

DD-5 PNEUPHONIC HORN

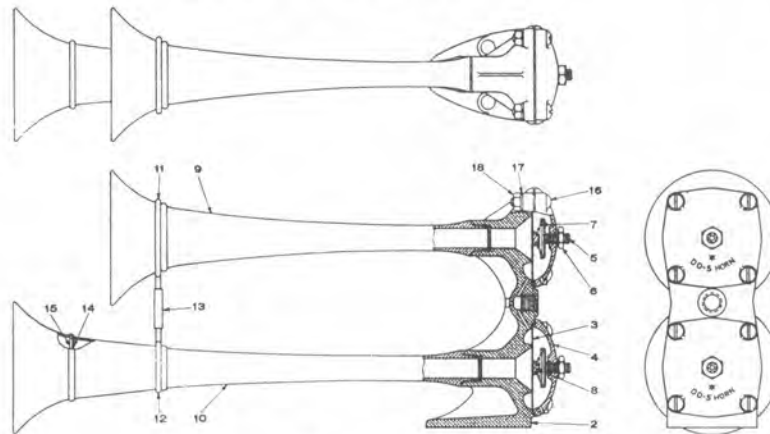

Net Weight 4 lbs.

Piece No. 524490 DD-5 Pneuphonic Horn, complete with Strainer

Piece No. 514065 DD-5 Pneuphonic Horn, complete less Strainer

Pc. No.	Ref. No.	Pc. No.	Ref. No.
514077	2	514085	11 Short Bell Clamp
514088	3	514086	12 Long Bell Clamp
514094	4	514087	13 Bell Connector
514080		514091	14 Screen (2 Req'd)
		514092	15 Screen Retainer (2 Req'd)
514081	5	513698	16 $\frac{1}{4}$ "-20 x 1" Rd. Hd. Mch. Screw (8 Req'd)
514096	6	10764	17 $\frac{1}{4}$ " Lock Washer (8 Req'd)
514089	7	93783	18 $\frac{1}{4}$ "-20 Hex. Nut (8 Req'd)
514090	8	95309	$\frac{1}{4}$ " OB-1 Air Strainer (for details see Part Catalog 3216-2 Sup. 11)
514078	9		
514079	10		

Prices will be quoted upon application.

Orders should give PIECE NUMBER and NAME of part wanted.

D-5 PNEUPHONIC HORN

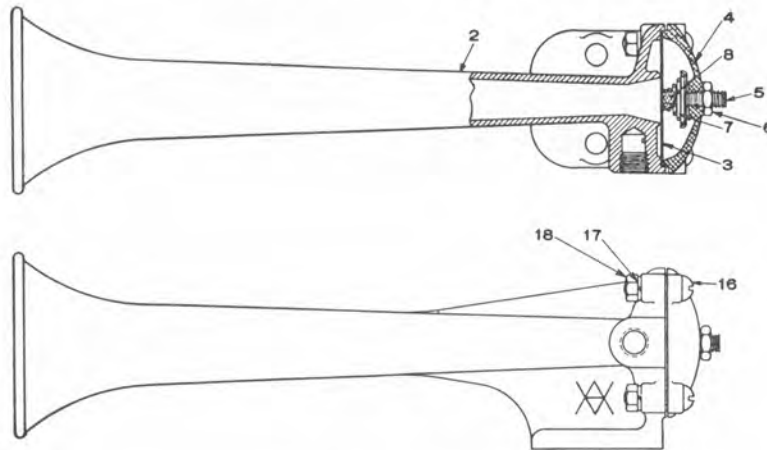

Net Weight $3\frac{3}{4}$ lbs.

Piece No. 524491 D-5 Pneuphonic Horn, Complete with Strainer

Piece No. 532654 D-5 Pneuphonic Horn, Complete less Strainer

Pc. No. Ref. No.

532655	2	Body and Bell
514088	3	Diaphragm
522242	4	Cover
514080		Spring Seat, Complete (includes 5 and 6)
514081	5	Spring Seat
514096	6	$\frac{3}{16}$ " Jam Nut

Pc. No. Ref. No.

514089	7	Spring
514090	8	Spring Contact
94266	16	$\frac{1}{4}$ " x $1\frac{1}{8}$ " Cover Screw (4 Req'd)
10764	17	$\frac{1}{4}$ " Lock Washer (4 Req'd)
93783	18	$\frac{1}{4}$ " Hex. Nut (4 Req'd)
95309		$\frac{1}{4}$ " OB-1 Air Strainer (for details see Part Catalog 3216-2 Sup. 11)

TROMBONE AND CLARION WHISTLES



Fig. 1
Net Weight $3\frac{3}{4}$ lbs.

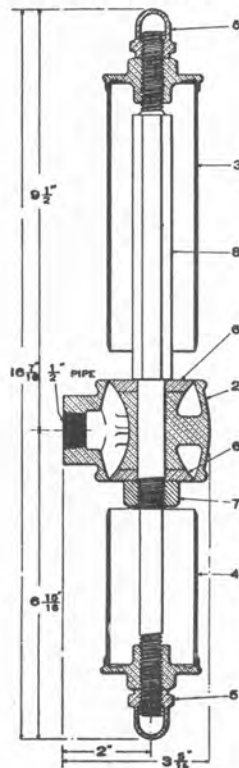

Fig. 2
Net Weight 5 lbs.

Piece No. 21313 Trombone Whistle,
Complete (Fig. 1)

Piece No. 19046 Clarion Whistle,
Complete (Fig. 2)

Pc. No. Ref. No.

18821	2	Body
18823	3	Long Whistle Bowl
18825	4	Short Whistle Bowl
18827	5	Lock Nut (2 Req'd)
18828	6	Disc (2 Req'd)
2519	7	Nut
18820	8	Stem

Prices will be quoted upon application.

Orders should give PIECE NUMBER and NAME of part wanted.

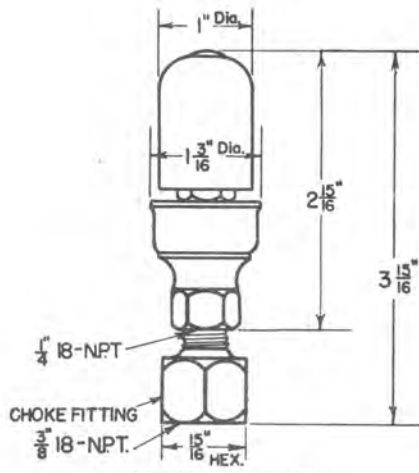

Net Weight $\frac{3}{8}$ lbs.
Bell Type

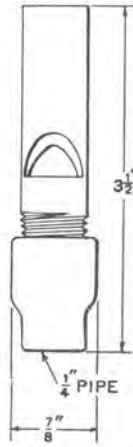

Net Weight $\frac{1}{4}$ lb.
Willow Type

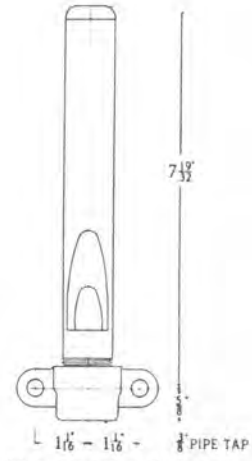

Net Weight $5\frac{1}{4}$ lbs.
H Type

- Piece No. 538210 Bell Type Signal Whistle, Complete (low pitch) (tapped for $\frac{1}{4}$ " pipe)
- Piece No. 540801 Bell Type Signal Whistle, Complete, with Choke Fitting (low pitch) ($\frac{1}{16}$ " drill) Tapped for $\frac{3}{8}$ " Pipe (Pc. 524126)
- Piece No. 528638 Bell Type Signal Whistle, Complete (medium pitch) (tapped for $\frac{1}{4}$ " pipe)
- Piece No. 531596 Bell Type Signal Whistle, Complete, with Choke Fitting (medium pitch) ($\frac{1}{16}$ " drill) Tapped for $\frac{3}{8}$ " Pipe (Pc. 524126)
- Piece No. 538406 Bell Type Signal Whistle, Complete (high pitch) (tapped for $\frac{1}{4}$ " pipe)
- Piece No. 538770 Bell Type Signal Whistle, Complete, with Choke Fitting (high pitch) ($\frac{1}{16}$ " drill) Tapped for $\frac{3}{8}$ " Pipe (Pc. 524126)
- Piece No. 40920 Willow Type Signal Whistle, Complete (tapped for $\frac{1}{4}$ " pipe)
- Piece No. 95659 "H" Type Whistle, Complete (tapped for $\frac{3}{8}$ " pipe)

$\frac{1}{2}$ " x $\frac{1}{2}$ " "H-6" WHISTLE VALVES

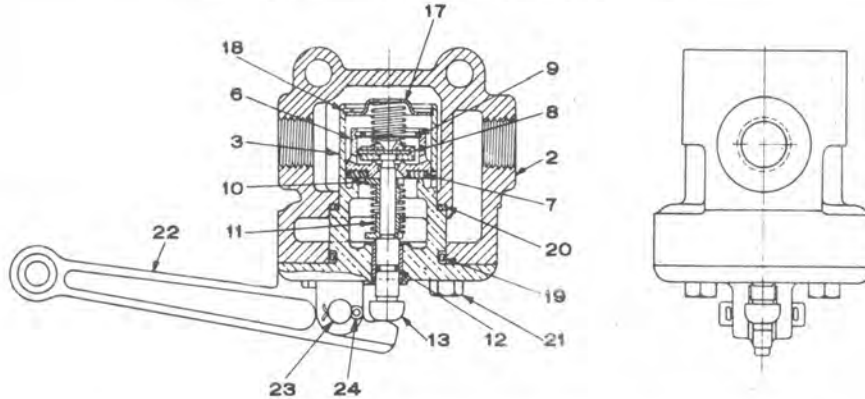

COMPLETE Pc. No.	VALVE		FOR USE WITH HORN
	Pc. No.	Choke Size	
540520	540627	.313"	E-2B-1, E-2B-2, E-2B-3 or two E-2's
543973	543974	.281"	E-2
548909	548908	.260"	B-7, AA-2
546169	546168	.252"	A-2, A-6

Pc. No.	Ref. No.		Pc. No.	Ref. No.	
540625	2	Whistle Valve Body	540629	13	Plunger
540626	3	Whistle Valve Body Cover	540630	17	Valve Stop
	6	Valve (See Schedule)	525924	18	Valve Stop Retaining Ring
540543	7	Valve Seal	542189	19	Cover Sealing Ring
505782	8	Check Valve	540542	20	Cover Gasket
541079	9	Check Valve Retaining Ring	512434	21	$\frac{3}{16}$ " x $\frac{3}{4}$ " Cover Cap Screw (4 Req'd)
540628	10	Spring Seat (2 Req'd)	540632	22	Handle
*87571	11	Spring (2 Req'd)	54330	23	Handle Pin
534662	12	$\frac{3}{8}$ " O.D. WABCO Packing Ring for Plunger	2958	24	$\frac{3}{32}$ " x $\frac{5}{8}$ " Cotter (2 Req'd)

*NOTE—For Spring Identification Table, see page 12.

Prices will be quoted upon application.
Orders should give PIECE NUMBER and NAME of part wanted.

WHISTLE VALVES

H-2 AND H-2-A WHISTLE VALVES

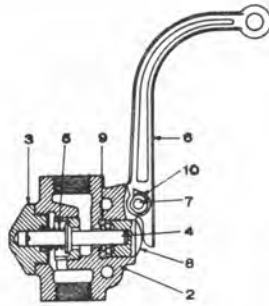

**H-2-A Type
with Handle A**

Approx. Net Weight
1 3/4 lbs.

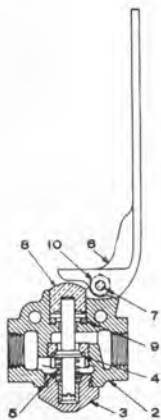

**H-2 Type
with Handle F**

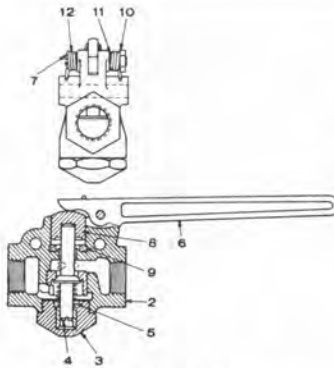

**H-2 Type with
Non-rattle Handle E**

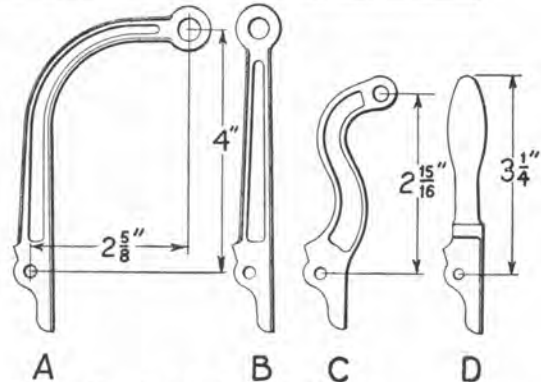

**Handles A, B, C and D
for H-2 and H-2-A Types**

H-3 WHISTLE VALVE

Pc. No. 529777 1/2" x 1/2" H-3 Whistle Valve,
Complete

Pc. No.	Ref. No.	Description
536266	2	Valve Body
526378	3	Cap Nut
536267	4	Valve
*536270	5	Spring (2 Req'd)
532712	6	Handle
26963	7	5/16" x 7/8" Handle Pin
536269	8	Plunger
12616	9	1/16" x 1/8" Pin
534662	10	Packing Ring

Approx. Net Weight 2 1/2 lbs.

*NOTE—For Spring Identification Table, See Page 12.
†Includes non-rattle handles.

Prices will be quoted upon application.

Orders should give PIECE NUMBER and NAME of part wanted.

Ref. No.		PC. NOS. BY TYPES	
		H-2	H-2-A
	3/8" x 3/8" Whistle Valve, Complete, with Handle A . . .	527751	90391
	3/8" x 3/8" Whistle Valve, Complete, with Handle B		90692
	3/8" x 3/8" Whistle Valve, Complete, with Handle D		503820
	1/2" x 1/2" Whistle Valve, Complete, with Handle A	538792	
	1/2" x 1/2" Whistle Valve, Complete, with Handle B	537780	
	1/2" x 1/2" Whistle Valve, Complete, with Handle C	538793	
	1/2" x 1/2" Whistle Valve, Complete, with Handle D	538794	
	1/2" x 1/2" Whistle Valve, Complete, with Handle E	†519737	
	1/2" x 1/2" Whistle Valve, Complete, with Handle F	528805	
	1/2" x 1/2" Whistle Valve, Complete, with Handle B	†540584	
2	3/8" x 3/8" Body	527750	520857
2	1/2" x 1/2" Body	519738	
3	Cap Nut	519741	519741
4	Valve	90388	90388
5	Spring	*3503	*3503
6	Handle A	31406	31406
6	Handle B	31408	31408
6	Handle C	31407	
6	Handle D	31413	31413
6	Handle E (Non-rattle type)	519743	
6	Handle F	528804	
7	Handle Screw (for all Pc. Nos. except 519737 and 540584)	522544	522544
7	Handle Screw (for Pc. Nos. 519737 and 540584)	519745	
8	Plunger	90389	90389
9	Gasket	90392	90392
10	Handle Screw Nut (for all Pc. Nos. except 519737 and 540584)	27396	27396
10	Handle Screw Nut (for Pc. Nos. 519737 and 540584)	519746	
11	Lock Washer (for Pc. Nos. 519737 and 540584)	519821	
12	Handle Spring (for Pc. Nos. 519737 and 540584)	*519744	

H-1 WHISTLE VALVES

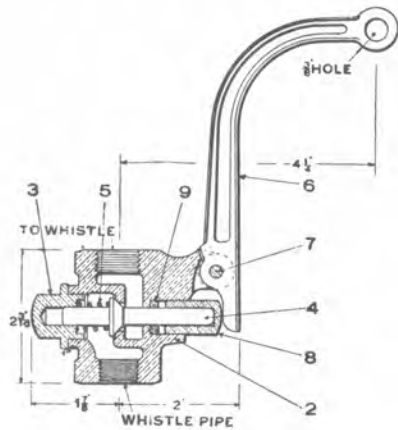

Net Weight 1 1/4 lbs.

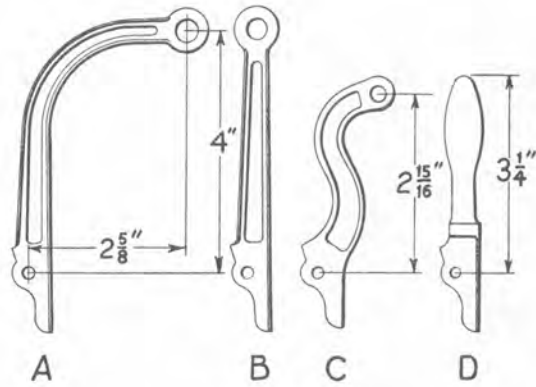

Handles A, B, C and D

Ref. No.	Description	PIECE NUMBERS BY HANDLE TYPE			
		Handle A	Handle B	Handle C	Handle D
	1/2" x 1/2" Whistle Valve, Complete	31418	31419	31420	31421
	1/2" x 3/8" Whistle Valve, Complete	31422	31423	31424	31425
	1/4" x 3/8" Whistle Valve, Complete	59322
2	Body (1/2" x 1/2")	31414	31414	31414	31414
2	Body (1/2" x 3/8" and 1/4" x 3/8")	31417	31417	31417	31417
3	Cap Nut	3501	3501	3501	3501
4	Valve	3500	3500	3500	3500
5	Spring	*3503	*3503	*3503	*3503
6	Handle	31406	31408	31407	31413
7	Handle Screw	3504	3504	3504	3504
8	Thimble	31415	31415	31415	31415
9	Thimble Seat	526539	526539	526539	526539
	1/2" x 1/4" Reducing Bush (for Pc. 59322)	43715

H-4-A WHISTLE VALVE

Piece No. 530927 H-4-A Whistle Valve, Complete, with 3/8" WABCOTITE® Sweat Fittings

Piece No. 533802 H-4-A Whistle Valve, Complete, less Fittings

Pc. No.	Ref. No.	Description
532718	2	Valve Body
532713	4	Plunger
524609	5	1/4" O.D. WABCO Packing Ring
532268	6	7/16" O.D. WABCO Packing Ring
*48367	7	Handle Return Spring
532710	8	Spring Seat
528643	9	Retaining Ring
532715	10	Check Valve
*185217	11	Check Valve Spring
526378	12	Cap Nut
521398	13	Filter (2 Req'd)
529162	14	Filter Retaining Ring (2 Req'd)
532712	15	Handle
26963	16	5/16" x 7/8" Handle Pin
532799	17	.0625" x 3/4" Pin
504721	25	3/8" WABCOTITE Sweat Fitting (2 Req'd)
93839	26	3/8" Fitting Gasket (2 Req'd)
7978	27	3/8" x 1" Fitting Cap Screw (4 Req'd)

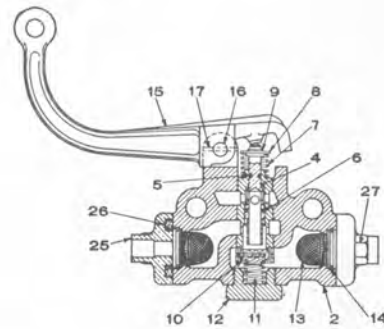

Net Weight 3 1/2 lbs.

*NOTE—For Spring Identification Table, see page 12.

Prices will be quoted upon application.
Orders should give PIECE NUMBER and NAME of part wanted

"A" FOOT OPERATED WHISTLE VALVE

Piece No. 85776 "A" Whistle Valve, Complete

Pc. No.	Ref. No.	
85777	2	Body, complete (Includes 10 and 11)
85782	3	Cap Nut
85780	4	Valve
*85781	5	Spring
12554	10	Gasket
85779	11	Plunger
85783	14	Escutcheon
85784	15	Plunger Cap
85785	16	Fil. Hd. Mach. Screw (2 Req'd)

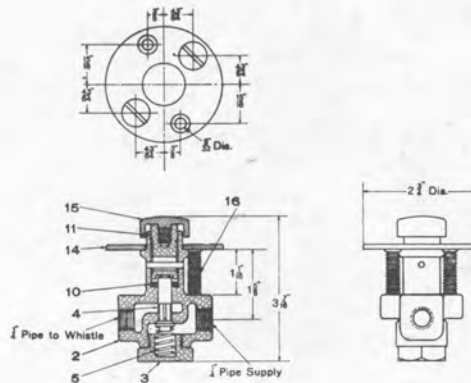

Net Weight 2 lbs.

P-1 PUSH BUTTON WHISTLE VALVE

Piece No. 92441 1/8" P-1 Whistle Valve, Complete
 Piece No. 515869 1/4" P-1 Whistle Valve, Complete

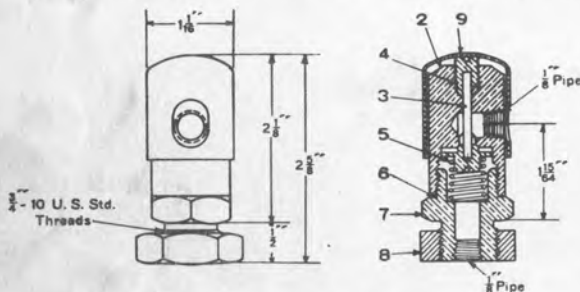

Net Weight 3/4 lbs.

1/4"		1/8"		Ref. No.	
Pc. No.		Pc. No.			
515844		92442		2	Body
515849		92445		3	Valve with Stem
92446		92446		4	Exhaust Check
* 89642		*89642		5	Valve Spring
515865		92447		6	Gasket
515845		92448		7	Nut
515848		44380		8	Hex. Nut
.....		92450		9	Valve Pusher
515846			9	Valve Pusher

***SPRING IDENTIFICATION**

The following table is shown to enable railroad men, storekeepers and all Air Brake men to identify the various springs used in the devices cataloged herein. It is based on calculated figures and the actual spring will vary somewhat, due to small difference in wire diameter, coil diameter, number of turns, etc. This tabulation is intended for identification only and should not be used for any other purpose. It does not represent a specification for the springs mentioned.



SPRING IDENTIFICATION

Pc. No.	Approx. Out. Dia. "A"	Approx. Dia. Wire "B"	Approx. Free Height "C"	† Approx. No. Turns	Material	Name of Spring	Where Used
87571	9/16"	.047"	1.5"	8	Steel	Valve	H-6 Whistle Valve
85781	7/16"	.0720"	7/8"	7	Phos. Bronze	Valve	"A" Whistle Valve
89642	7/16"	.032"	13/16"	6	Phos. Bronze	Valve	P-1 Whistle Valve
3503	1/2"	.072"	5/8"	4 3/4"	Phos. Bronze	Valve	H-1 & H-2 Whistle Valves
536270	1/2"	.055"	27/32"	6 3/4"	Steel	Valve and Handle	H-3 Whistle Valve
185217	13/32"	.032"	25/32"	6 1/2"	Steel	Valve	H-4-A Whistle Valve
48367	9/16"	.042"	1 1/4"	5 1/2"	Steel	Handle Return	H-4-A Whistle Valve
519744	Special Double Torsion Spring				Steel	Handle	H-2 Whistle Valve

†Number of turns for each spring counted between extreme ends of the wire.

Prices will be quoted upon application.
 Orders should give PIECE NUMBER and NAME of part wanted.

	Page		Page
Wear Plates-Center		Wheel	
Renewal	46	Removal	53
		Mounting	53
Wear Plates-Journal		Wheel & Axle Assemblies-Motor	
Lubrication	14-18	Removal	46
Renewal	34	Assembly	48
Weights-Locomotive Parts	1	Wheel Diameters	1

WHEN YOU NEED SERVICE

IF YOU NEED TO REPAIR, recondition, or rebuild any electric apparatus, a G-E service shop near you is available day and night, seven days a week, for work in the shops or on your premises. Latest factory methods and genuine G-E renewal parts are used to maintain the original performance of your G-E equipment. For full information about these services, contact the nearest service shop or sales office listed below:

APPARATUS SERVICE SHOPS

Allentown, Pa. 672-676 E. Highland St.
 Appleton, Wisc. Midway Industrial Area,
 County Trunk, "P"
 Atlanta—Chamblee, Ga. 4639 Peachtree
 Indus. Blvd.
 Baltimore 30, Md. 920 E. Fort Ave.
 Boston—Medford 55, Mass. Mystic Valley Pkwy.
 Buffalo 11, N. Y. 318 Urban St.
 Charleston 28, W. Va. 306 MacCorkle Ave., S.E.
 Charlotte, N. C. 2328 Thrift Road
 Chicago 32, Ill. 4360 W. 47th St.
 Cincinnati 2, Ohio 444 W. Third St.
 Cleveland 4, Ohio 4966 Woodland Ave.
 Columbus 23, Ohio 2128 Eakin Rd.
 Corpus Christi, Texas 115 Busse St.
 Dallas 19, Texas 3202 Manor Way
 Davenport—Bettendorf, Ia. 1039 State St.
 Decatur, Ill. 2225 E. Logan St.
 Denver 5, Colo. 3353 Larimer St.
 Detroit 2, Mich. 5950 Third Ave.
 Houston 20, Texas 5534 Harvey Wilson Drive
 Indianapolis 22, Ind. 1740 W. Vermont St.
 Johnstown, Pa. 841 Oak St.
 Kansas City, Mo. 3525 Gardner Ave.
 Los Angeles 1, Calif. 6900 Stanford Ave.
 Louisville, Ky. 2014 New Main St.
 Midland, Tex. 3404 Bankhead Hwy.
 Milwaukee 3, Wisc. 940 W. St. Paul Ave.
 Minneapolis 12, Minn. 2025 49th Ave., N.
 New Orleans, La. 2815 N. Robertson St.
 New York—N. Bergen, N. J. 6001 Tonnelle Ave.
 Oakland, Calif. 1525 Peralta St.
 Philadelphia 24, Pa. 1040 E. Erie Ave.
 Pittsburgh 6, Pa. 6519 Penn Ave.
 Portland 10, Oregon 2727 N.W. 29th Ave.
 Richmond 24, Va. 1403 Ingram Ave.
 Roanoke, Va. 115 Albermarle St.
 Sacramento, Calif. 99 N. 17th St.
 St. Louis 10, Mo. 1115 East Road
 Salt Lake City 4, Utah 301 S. Seventh West St.
 San Francisco 3, Calif. 1098 Harrison St.
 Seattle 4, Wash. 3422 First Ave., S.
 Southington, Conn. 53 Railroad Ave.
 Spokane 3, Wash. S. 155 Sherman St.
 Tampa 1, Fla. P.O. Box 1245,
 Naval Indus. Res. Shipyard
 Toledo 4, Ohio 1 So. St. Clair St.
 Wheeling, W. Va. 2050 National Rd.
 York, Pa. 54 N. Harrison St.
 Youngstown 5, Ohio 272 E. Indianola Ave.

APPARATUS SALES OFFICES

Abilene, Texas 442 Cedar St.
 Akron 8, Ohio 335 S. Main St.
 Albany 7, N. Y. 90 State St.
 Albuquerque, N. Mex. 323 Third St., S.W.
 Alexandria, La. 720 Murray St.
 Allentown, Pa. 1132 Hamilton St.
 Amarillo, Texas Amarillo Bldg.
 Appleton, Wisc. 531 W. College Ave.
 Atlanta 3, Ga. 1860 Peachtree Rd., N.W.
 Augusta, Ga. Masonic Bldg.
 Augusta, Me. 152 State St.
 Baltimore 1, Md. 111 Park Ave.
 Bangor, Maine 77 Central St.
 Baton Rouge 6, La. 3170 Florida Blvd.
 Battle Creek, Mich. 25 W. Michigan Ave.
 Beaumont, Texas 1385 Calder Ave.
 Billings, Mont. Rm. 816, 303 No. Broadway
 Birmingham, N. Y. 19 Chenango St.

Birmingham 3, Ala. 1804 Seventh Ave., N.
 Bismarck, N. Dak. 418 Rosser Ave.
 Bluefield, W. Va. 704 Bland St.
 Appalachian Bldg.
 Boise, Idaho 1524 Idaho St.
 Boston 1, Mass. 140 Federal St.
 Buffalo 3, N. Y. 535 Washington St.
 Butte, Mont. P.O. Box 836, 103 N. Wyoming St.
 Canton 2, Ohio 700 Tuscarawas St., W.
 Cedar Rapids, Iowa 210 Second St., S.E.
 Charleston 28, W. Va. 306 MacCorkle Ave., S.E.
 Charlotte 1, N. C. 112 S. Tryon St.
 Chattanooga 2, Tenn. 832 Georgia Ave.
 Chicago 80, Ill. P.O. Box 5970A, 840 S. Canal St.
 Cincinnati 2, Ohio 215 W. Third St.
 Cleveland 4, Ohio 4966 Woodland Ave.
 Columbia 1, S.C., P.O. Box 1434, 1420 Lady St.
 Columbus 15, Ohio 40 S. Third St.
 Corpus Christi, Texas 205 N. Chaparral
 Dallas 2, Texas 1801 N. Lamar St.
 Davenport—Bettendorf, Ia. 1039 State St.
 Dayton 2, Ohio 11 W. Monument Bldg.
 Dayton 9, Ohio Avia. & Def.,
 2600 Far Hills Ave.
 Denver 2, Colo. 650 Seventeenth St.
 Des Moines 9, Iowa 505 W. Fifth Ave.
 Detroit 2, Mich. 700 Antoinette St.
 Duluth 2, Minn. 14 W. Superior St.
 Elmira, N. Y. Main and Woodlawn Aves.
 El Paso, Texas 215 No. Stanton
 Erie, Pa. 1001 State St.
 Eugene, Ore. Cascade Bldg., 1170 Pearl St.
 Evansville 19, Ind. 123 N.W. Fourth St.
 Fairmont, W. Va. 310 Jacobs Bldg.,
 P.O. Box 1626
 Fergus Falls, Minn. 108 N. Court Ave. P.O. Box 197
 Flint 3, Mich. 653 S. Saginaw St.
 Fort Wayne 6, Ind. 3606 So. Calhoun St.
 Fort Worth 2, Tex. 408 W. Seventh St.
 Fort Worth, Tex. Avia. & Def.,
 6200 Camp Bowie Blvd.
 Fresno 1, Calif. 407 Patterson Bldg.,
 Tulare and Fulton St.
 Grand Rapids 2, Mich. 425 Cherry St., SE
 Greensboro, N. C. 301 S. Elm St.
 Greenville, S. C. 108 W. Washington St.
 Gulfport, Miss. 207 Jo-Fran Bldg.
 Hagerstown, Md. Professional Arts Bldg.
 Hartford 5, Conn. 764 Asylum Ave.
 Houston 1, Texas 1312 Live Oak St.
 Indianapolis 4, Ind. 110 N. Illinois St.
 Jackson, Mich. 120 W. Michigan Ave.
 Jackson 1, Miss. 203 W. Capitol St.
 Jacksonville 2, Fla. 700 E. Union St.
 Jamestown, N. Y. P.O. Box 548, 2 Second St.
 Johnstown, Pa. 841 Oak St.
 Joplin, Mo. P.O. Box 948, 220½ W. Fourth St.
 Kalamazoo 3, Mich. 112 Parkway Ave.
 Kansas City 6, Mo. 106 W. Fourteenth St.
 Knoxville 16, Tenn. 1301 Hannah Ave.
 Lake Charles, La. 422 Seventh St.
 Lansing 8, Mich. 306 Michigan National Tower
 Lexington, Ky. First National Bank Bldg.
 Lincoln 8, Nebr. Sharpe Bldg., 206 S. 13th St.
 Little Rock, Ark. 103 W. Capitol Ave.
 Los Angeles 54, Calif. 212 N. Vignes St.
 Louisville 2, Ky. 455 S. Fourth St.
 Lubbock, Texas 3302 Avenue "A"
 Macon, Ga. 682 Cherry St.
 Madison 3, Wisc. 16 N. Carroll St.
 Manchester, N. H. 875 Elm St.

Medford, Ore., P.O. Box 1349, 107 E. Main St.
 Memphis 3, Tenn. 8 N. Third St.
 Miami 32, Fla. 25 S.E. Second Ave.
 Midwest City, Okla. Avia. & Def.,
 207 Post Off. Bldg.
 Milwaukee 3, Wisc. 940 W. St. Paul Ave.
 Minneapolis 3, Minn. 12 S. Sixth St.
 Mobile 13, Ala. 54 St. Joseph St.
 Nashville 3, Tenn. 234 Third Ave., N.
 Newark 2, N. J. 744 Broad St.
 New Haven 6, Conn. 129 Church St.
 New Orleans 12, La. 837 Gravier St.
 New York 22, N. Y. 570 Lexington Ave.
 New York Avia. & Def., Fed. Bldg.,
 N. Y. International Airport, Jamaica 30, N. Y.
 Niagara Falls, N. Y. 253 Second St.
 Norfolk 10, Va. 229 W. Bute St.
 Oakland 12, Calif. 409 Thirteenth St.
 Oklahoma City 2, Okla. 119 N. Robinson St.
 Omaha 2, Nebr. 409 S. Seventeenth St.
 Pasco, Wash. 824 W. Lewis St.
 Peoria 2, Ill. 309 Jefferson Bldg.
 Philadelphia 2, Pa. 1405 Locust St.
 Phoenix, Ariz. P.O. Box 4037, 303 Luhrs Tower
 Pittsburgh 22, Pa. The Oliver Bldg., Mellon Sq.
 Portland 7, Ore. 920 S.W. Sixth Ave.
 Providence 3, R. I. Industrial Trust Bldg.
 Raleigh, N. C. Room 401, 16 W. Martin St.
 Reading, Pa. 31 N. Sixth St.
 Richmond 17, Va. 700 E. Franklin St.
 Riverside, Calif. 3570 Ninth St.
 Roanoke 16, Va. 920 S. Jefferson St.
 Rochester 4, N. Y. 89 E. Ave.
 Rockford, Ill. 110 S. First St.
 Rutland, Vt. 38½ Center St.
 Sacramento 14, Calif. 626 Fomer Bldg.
 Saginaw, Mich. Second National Bank Bldg.
 St. Louis 1, Mo. 818 Olive St.
 Salt Lake City 9, Utah 200 S. Main St.
 San Antonio 5, Texas 434 So. Main Ave.
 San Diego 1, Calif. 1240 Seventh Ave.
 San Francisco 6, Calif. 235 Montgomery St.
 San Jose 10, Calif. 460 Park Ave.
 Savannah, Ga. 4 E. Bryan St.
 Seattle 4, Wash. 710 Second Ave.
 Seattle 8, Wash. Avia. & Def., 220 Dawson St.
 Shreveport, La. 206 Beck Bldg.
 Sioux City 13, Iowa 572 Orpheum Electric Bldg.
 South Bend 1, Ind. 112 W. Jefferson Blvd.
 Spokane 4, Wash. S. 162 Post St.
 Springfield, Ill. 607 E. Adams St.
 Springfield 3, Mass. 1387 Main St.
 Stockton, Calif. 11 So. San Joaquin St.
 Syracuse 6, N. Y. 3532 James St.
 Tacoma 1, Wash. 1202 Washington Bldg.
 Tampa 6, Fla. 1206 North A St.
 Toledo 4, Ohio 420 Madison Ave.
 Trenton 8, N. J. 214 E. Hanover St.
 Tucson, Ariz. P.O. Box 710, 650 N. Sixth Ave.
 Tulsa 3, Okla. 320 S. Boston Ave.
 Utica 2, N. Y. 258 Genesee St.
 Washington 5, D. C. 777-14th St., N.W.
 Waterloo, Iowa 206 W. 4th St.
 Wenatchee, Wash. 328 N. Wenatchee Ave.
 Wheeling, W. Va. 40 Fourteenth St.
 Wichita 2, Kan. 200 E. First St.
 Williamston, N. C. 115 E. Main St.
 Worcester 5, Mass. 288 Grove St.
 York, Pa. 56 N. Harrison St.
 Youngstown 5, Ohio 272 E. Indianola Ave.